

SOUTHEAST POLICY AREA

SPECIAL PLANNING AREA

LANDSCAPE PLANNING PROTOTYPE MANUAL



ADOPTED AUGUST 2016

ACKNOWLEDGMENTS

City Council

Gary Davis, *Mayor*
Darren Suen, *District 1*
Pat Hume, *District 2*
Steven Detrick, *District 3*
Steve Ly, *District 4*

City Staff

Laura Gill, *City Manager*
Jason Behrmann, *Assistant City Manger*
Darren Wilson, PE, *Development Services Director*
Christopher Jordan, AICP, *Assistant to the City Manager*

Planning Commission

George Murphy, *Chair*
Fedolia “Sparky” Harris, *Vice-Chair*
Amy Tong, *Commissioner*
Frank Maita, *Commissioner*
Kevin Spease, *Commissioner*

Cosumnes Community Services District

Jeff Ramos, *General Manager*
Bob Roessler, *Administrator of Parks and Recreation*
Paul Mewton, *Chief of Planning, Design, & Construction*

Project Team



(Planning, Development, Project Management)
Steven Canada, *Senior Principal Landscape Architect*
Anthony Mendoza, *Job Captain*
Hilary Harkins, *Landscape Designer*

DIRECTOR'S APPROVAL

I Darren Wilson, PE, as Development Services Director for the City of Elk Grove, do hereby approve this document as the Landscape Planning Prototype Manual pursuant to Chapter 5 (Design Protocol) of the Southeast Policy Area Special Planning Area (SEPA SPA),



Darren Wilson, PE
Development Services Director



Date

This page intentionally left blank.

TABLE OF CONTENTS

1. INTRODUCTION & IMPLEMENTATION

A. CHAPTER OVERVIEW & MANUAL ORGANIZATION	1-1
B. COMMUNITY THEME AND IDENTITY STATEMENT	1-3
C. IMPLEMENTATION	1-4

2. STREETS & STREET LANDSCAPING

A. CHAPTER OVERVIEW	2-1
B. GENERAL STANDARDS & REFERENCE ITEMS	2-2
1. General Landscaping Standards	2-2
2. Reference Items	2-5
C. LANDSCAPE MEDIAN/ TURN POCKET DESIGN & STREET MATERIALS	2-6
1. Landscape Median/Turn Pocket	2-6
2. Colored Stamped Concrete Maintenance Safety Strip at Landscape Median/Turn Pocket	2-7
3. Colored Concrete Enhanced Paving	2-8
4. Colored Stamped Asphalt Enhanced Paving Crosswalks	2-9

- D. LANDSCAPE CORRIDORS..... 2-10**
 - 1. Landscape Corridors Plan 2-10
 - 2. Kammerer Road 2-11
 - 3. Arterial 2-12
 - 4. Arterial with Transit Corridor (Temporary Landscaping) 2-13
 - 5. Arterial with Transit Corridor (Completed Transit Connection)... 2-14
 - 6. Collector - Commercial..... 2-15
 - 7. Commercial Main Street 2-16
 - 8. Collector - Residential (With Median, No On-Street Parking) 2-17
 - 9. Collector - Residential (With On-Street Parking, No Median) 2-18
 - 10. Primary Residential Street 2-19
 - 11. Local Residential Street 2-20
 - 12. Local Estate Residential Street 2-21
- E. RESIDENTIAL UNIT FRONT YARDS 2-22**
- F. BRIDGES 2-23**
 - 1. Vehicular Bridge..... 2-23

3. ENTRY MONUMENTS, WALLS & FENCES

- A. CHAPTER OVERVIEW..... 3-1**
- B. GENERAL STANDARDS & REFERENCE ITEMS 3-2**
 - 1. Materials Standards 3-2
 - 2. General Landscaping Standards..... 3-6
 - 3. Lettering & Logo Standards 3-7
 - 4. Reference Items 3-12

C. ENTRY MONUMENTS..... 3-13

- 1. Overview 3-13
- 2. Application List 3-14
- 3. Entry Monument Plan 3-15
- 4. Primary Entry Monument 3-16
- 5. Secondary Entry Monument 3-20
- 6. Neighborhood Entry Monument Overview 3-24
- 7. Neighborhood Entry Monument #1 3-24
- 8. Neighborhood Entry Monument #2 3-28
- 9. Neighborhood Entry Monument #3 3-32
- 10. Neighborhood Entry Monument #4 3-36
- 11. Gateway Features 3-40
- 12. Employment Area Entry Monuments 3-40

D. WALLS & FENCES 3-42

- 1. Overview 3-42
- 2. Walls & Fences Plan 3-43
- 3. Community Pilaster 3-44
- 4. Low Pilaster 3-44
- 5. Community Walls 3-45
- 6. Residential Wood Fence 3-47
- 7. Open View Fence 3-47
- 8. Open View Fence with Low Wall 3-48
- 9. Split Rail Fence 3-48
- 10. Post and Cable Fence 3-48
- 11. Other Walls & Fences 3-49

4. STREETSCAPE MATERIALS, SITE FURNISHINGS & PROJECT AMENITIES

A. CHAPTER OVERVIEW	4-1
B. STANDARDS & MATERIALS	4-2
1. Bench.....	4-2
2. Picnic Table - 6’ Length.....	4-2
3. Picnic Table - 8’ Length.....	4-2
4. Trash Receptacle	4-3
5. Recycle Receptacle	4-3
6. Bike Rack	4-3
7. Drinking Fountain.....	4-4
8. Tree Grate.....	4-4
9. Dog-Litter Bag Dispenser	4-4
10. Root Barrier	4-5
11. Redwood Header.....	4-5
12. Concrete Mowstrip	4-5
13. Stationary Bollard	4-5
14. Knock-Down Bollard.....	4-5
15. Lighted Bollard	4-5
16. Street Lighting	4-6
17. Informational Kiosk.....	4-8
18. Directional Wayfinding Signage.....	4-8
19. Pedestrian Bridge	4-9

5. GREENWAYS, DRAINAGE CORRIDORS & FACILITIES

- A. CHAPTER OVERVIEW..... 5-1**
- B. GENERAL STANDARDS & REFERENCE ITEMS 5-3**
 - 1. General Landscaping Standards..... 5-3
 - 2. Reference Items 5-5
- C. GREENWAYS, DRAINAGE CORRIDORS & FACILITIES PLAN/
SHARED-USE PATH PLAN..... 5-7**
- D. GREENWAYS, DRAINAGE CORRIDORS & FACILITIES..... 5-8**
 - 1. Greenways..... 5-8
 - 2. Major Drainage Channel 5-10
 - 3. Detention Basin 5-12
 - 4. Joint-Use Park/Detention Facility..... 5-14

6. PLANT PALETTES, PLANTING & IRRIGATION REQUIREMENTS

- A. CHAPTER OVERVIEW..... 6-1**
- B. GENERAL PLANTING & IRRIGATION STANDARDS..... 6-2**
 - 1. General Planting Requirements 6-2
 - 2. General Irrigation Requirements 6-4
- C. PLANT PALETTES..... 6-5**
 - 1. General Landscaping Plant Palette 6-5
 - 2. Drainage Areas Plant Palette 6-11
 - 3. Prohibited Plant List 6-12
- D. PRIMARY STREET TREE PLAN..... 6-14**

CHAPTER 1

INTRODUCTION & IMPLEMENTATION

SOUTHEAST POLICY AREA

SPECIAL PLANNING AREA

LANDSCAPE PLANNING PROTOTYPE MANUAL

CHAPTER 1

INTRODUCTION & IMPLEMENTATION

A. CHAPTER OVERVIEW & MANUAL ORGANIZATION

The Southeast Policy Area Landscape Planning Prototype Manual (Manual) specifies landscape design guidelines within the Southeast Policy Area (Plan Area). It also supplements the Southeast Policy Area Special Planning Area document (SPA), as well as the requirements of the Elk Grove Municipal Code and other City of Elk Grove (City) policies and design guidelines.

This Manual intelligently outlines the design standards within the Plan Area, guiding the physical implementation of design elements that create the image, identity and theme of the Plan Area. It is the consistent and comprehensive application of these design elements that will highlight and strengthen the unique character of the Plan Area and establish it as a distinct and stand-alone region of the City.

Please note that traditional recreation park design guidelines are not included in this Manual, as these areas have very specific requirements and standards as set forth by the Cosumnes Community Services District (CCSD). The user shall refer to the CCSD for all recreation and park design requirements and standards.

CHAPTER 1

INTRODUCTION & IMPLEMENTATION: CHAPTER OVERVIEW & MANUAL ORGANIZATION

This Manual provides concise design direction and establishes design standards specific to the Plan Area. As development will occur over multiple years, the standards set forth in this Manual specify materials as well as provide implementation of landscape elements. These design elements may be substituted from those specified in this Manual as long as the design consistency is preserved throughout the Plan Area. Any deviation from design intent or materials as specified in this Manual shall be approved by the City prior to construction.

Manual Organization



Chapter 2: Streets and Street Landscaping

Establishes design requirements and guidelines for the landscape treatment along streets within the Plan Area including landscape amenities, site furnishings and plant material. This chapter includes plan views to illustrate specific elements that exist along a particular street type.



Chapter 3: Entry Monuments, Walls & Fences

Identifies and locates the various entry monuments, walls and fences which are proposed within the Plan Area. It also describes the materials and requirements associated with each monument, wall and fence.



Chapter 4: Streetscape Materials, Site Furnishings & Project Amenities)

Identifies the landscape materials, furnishings and amenities that have been selected for inclusion within the Plan Area. This chapter includes photos, plan views, descriptions, and distribution information for each element.



Chapter 5: Greenways, Drainage Corridors & Facilities

Establishes design requirements and guidelines for landscape treatment along greenways, drainage corridors and drainage facilities. This chapter includes plan views to illustrate the specific elements that exist within greenways, drainage corridors and drainage facilities.



Chapter 6: Plant Palettes, Planting & Irrigation Requirements

Identifies approved plant palettes within the Plan Area, including greenways and drainage areas. It also describes general irrigation and planting requirements within the Plan Area.

B. COMMUNITY THEME AND IDENTITY STATEMENT



At its core, the Southeast Policy Area is an employment-oriented community, which supports and encourages the development of employment, commercial and residential uses. Design standards have been put into place to implement the vision of creating a “live, work, play” community with multiple land uses existing in the same area. This Manual provides users with the guidelines and elements required to create a strong sense of identity, community and development, at a personal scale within the Plan Area. As set forth in this Manual, the overall concept for the landscape materials palette is to create a more “contemporary” feel to the Plan Area, with the use of clean lines and natural materials including stone, concrete and metal. Basic elements include manufactured stone veneer in cool, natural colors, which shall be the predominant accent material for Entry Monuments, walls and pilasters. Other elements include various types of metals, which not only add durability and ease of maintenance, but also create visual cohesion between the office and light industrial land uses and the residential land uses. Landscape amenities and site furnishings have also been selected to conform to and compliment the site architectural elements and material palette developed for the Plan Area. All landscape amenities and site furnishings are functional in design, create a pedestrian-friendly scale, and reinforce the overall identity and image of the community. Additionally, the plant palette has an emphasis on color, texture and layered forms to add a distinctive richness. All of the elements “create a sense of place” where people can live, work, shop and socialize in their community without need to leave the Plan Area.

CHAPTER 1

INTRODUCTION & IMPLEMENTATION: IMPLEMENTATION

C. IMPLEMENTATION

This Manual is a supplemental document to the SPA document and provides landscape design guidelines for various land uses, street landscaping, public spaces, greenways, landscape corridors and drainage facilities within Plan Area.

Additionally, exhibits within this Manual use the same land plan as the adopted SPA document. Please note, the exhibits contained within the following chapters are not intended to be overlaid with existing parcel lines. Rather, these exhibits have an inherent flexibility until the final configuration of all land uses is determined.

For all general considerations and requirements, including landscape requirements within the City, please refer to the following:

1. ***Southeast Policy Area Community Plan***, latest edition with all Amendments, Additions and Modifications.
2. ***Southeast Policy Area Special Planning Area document (SPA)***, latest edition with all Amendments, Additions and Modifications.
3. ***City of Elk Grove Improvement Standards***, latest edition with all Amendments, Additions and Modifications.
4. ***City of Elk Grove Municipal Code***, latest edition with all Amendments, Additions and Modifications.
5. ***California Building Code***, latest edition with all Amendments, Additions and Modifications.
6. ***Parks and Recreation Master Plan***, latest edition, Cosumnes CSD and the City.
7. ***Stormwater Quality Design Manual for the Sacramento Region***, latest edition, Sacramento Stormwater Quality Partnership.



CHAPTER 2

STREETS & STREET LANDSCAPING

**SOUTHEAST
POLICY AREA**

SPECIAL PLANNING AREA

LANDSCAPE PLANNING PROTOTYPE MANUAL

CHAPTER 2

STREETS & STREET LANDSCAPING

A. CHAPTER OVERVIEW

The landscape treatment for streets is designed to create a natural and cohesive landscape pattern throughout the community. Consistent treatments including landscape amenities and site furnishings located along various Landscape Corridors provide pedestrian scale and reinforce the overall identity and image of the community. Plantings including street trees, secondary trees, accent trees and shrubs create uniformity along Landscape Corridors and supplement the landscape character in making the pedestrian experience enjoyable. The plant palette has been selected to reinforce the character of the region and the City. Plant material located along Landscape Corridors is limited to those specified in this Manual's plant palette. All elements within a Landscape Corridor, including landscape amenities, site furnishings and plant material, shall be consistent over the length of the entire street. Any substitutions to plant material, landscape amenities, and/or site furnishings from those listed in this Manual shall be approved by the City. Additionally, landscape improvements within a Landscape Corridor shall be in conformance with the City's Municipal Code.

Note: Refer to the SPA, Chapter 4 for street sections and locations of Landscape Corridors (which include Landscape Areas).

B. GENERAL STANDARDS & REFERENCE ITEMS

1. General Landscaping Standards

The following is a list of general landscaping standards for all street Landscape Corridors and Landscape Median/Turn Pockets.

1. Landscape Area grading and slopes shall not exceed 5:1 for turf areas and 4:1 for planting areas. If Landscape Area grading or slopes exceed these ratios, a split face keystone retaining wall shall be required. All retaining walls shall be reviewed and approved by the City and CCSD.
2. The minimum planting size for a tree located within a Landscape Corridor shall be 15-gallon, with one-third (1/3) of all trees being 24" box or larger.
3. All street trees shall be selected from the Primary Street Tree List, as contained in the General Landscape Plant Palette.
(Refer to Chapter 6)
4. Primary Streets Trees shall be specified per the following (Refer to Chapter 6 for more information):
 - Major Street Tree Plan
 - General Planting Requirements
5. Street Trees shall be located at a 40' on center spacing.
6. Specimen Trees shall be planted at all Entry Monuments. (Refer to Chapter 3 for additional information on location and size of Specimen Trees and Chapter 6 for Specimen Tree list contained in the General Landscape Plant Palette.)
7. Landscape Median Trees shall be located at a 35' on center spacing.
8. Landscape Median Accent Trees at Landscape Median nosing shall be located at a 25' on center spacing. Three (3) Landscape Median Accent Trees shall be specified at each Landscape Median nosing. (Refer to the Landscape Median/Turn Pocket in this chapter for more information and Chapter 6 for Median Accent Tree list contained in the General Landscape Plant Palette.)
9. Secondary Trees or Accent Trees located within the Landscape Area of a Landscape Corridor (not Landscape Median/Turn Pockets) shall occur in informal groupings of three or five trees of the same species, planted between the sidewalk and adjacent land use property line. Mixed massings of flowering trees and evergreen species are encouraged.
10. Street Trees and Secondary Trees or Accent trees shall be a combination of deciduous and evergreen trees for purposes of screening and creating seasonal change. A minimum of 30% of the Street Trees and Secondary or Accent trees on a particular street shall be evergreen species.
11. All Street Trees shall be staked per City requirements.
12. All trees planted within 10 feet of a street, sidewalk, paved trail, walkway or plaza element shall be separated by a tree root barrier to prevent damage to public improvements and private property. The tree root barrier shall be installed at time of planting of the tree. (Refer to Tree Root Barrier, Chapter 4)
13. A minimum distance of 15' is required between the center of a tree and all light standards.

14. Shrub plantings adjacent to walls and fences shall be group massings, layered to provide visual interest. Variety in height is encouraged. Multiple rows of layered plantings are encouraged where space is adequate.
15. All shrub planting (i.e. small, medium, large) along any Landscape Corridor and intersections containing entry monuments shall be a minimum of 5-gallon in size. When shrubs are planted to serve as a hedge or screen, the shrub shall be planted at a spacing relative to the plant species' mature width (a shrub with a four foot wide mature width shall be planted at four feet on center). Plants that are not commercially available in a 5-gallon size, may be substituted with a 1-gallon size.
16. When a particular size plant is specified across large sections of a Landscape Corridor (i.e. medium shrub), the landscape architect shall use alternating groupings of plants from that specific section of the General Landscape Plant Palette (refer to Chapter 6) to achieve a planting design that has different genus and species along the entire streetscape. This shall be done to prevent a monolithic plant palette extending along the entire Landscape Corridor.
17. All groundcover planting shall be 1-gallon or grown in flats of up to 64 plants. Root cuttings from plants shall not be located greater than 12 inches on center spacing. Containerized 1-gallon groundcover plants shall not be located greater than 3' on center spacing.
18. Landscape Median plantings shall include evergreen shrubs and groundcover. Deciduous shrubs and groundcover are discouraged in street Landscape Medians.
19. Groundcover plantings shall be located between all separated sidewalks and back of curb/right-of-way ("ROW") along all publicly maintained Landscape Corridors, or as determined by the City.
20. A 3" layer of walk-on type bark mulch shall be located in all planter areas around trees, shrubs and groundcover within all Landscape Corridors.
21. Locations of colored concrete enhanced paving shall be submitted and evaluated at the entitlement stage of each development project.
22. Landscape Median/Turn Pockets include a colored stamped concrete maintenance safety strip (Refer to Colored Stamped Concrete Maintenance Safety Strip at Landscape Median/Turn Pocket in this chapter for more information).
23. All Landscape Median/Turn Pockets and landscape improvements located within the street ROW shall be considered public improvements and shall comply with all City requirements. Additionally, all plant material within the public improvements area shall be approved by the CCSO.
24. At single family residential land use adjacent to Arterial Streets, a Community Wall shall be located within the 24' Landscape Area with the back of wall located on the property line.

CHAPTER 2

STREETS & STREET LANDSCAPING: GENERAL STANDARDS & REFERENCE ITEMS

25. Temporary landscaping, including a complete irrigation system, redwood headerboard and groundcover planting shall be installed within the transit corridor until the transit connection is completed.
 26. All bulbouts shall be planted in a combination of shrubs and groundcover, and/or concrete paving as applicable to adjacent land use.
 27. All tree grates shall be located at back of curb. Tree guards shall not be installed.
 28. Commercial Main Street tree wells shall be 6' x 6' minimum and contain structural soil and tree root barriers at edge of tree well to prevent damage to paving. The tree root barrier shall be installed at time of planting of the tree. (Refer to Tree Root Barrier, Chapter 4). Planting media, structural soil, tree root barriers, and tree grates shall be reviewed and approved by the CCSD.
 29. Commercial Main Street Stormwater Planters (if required by the City) shall conform to the design criteria, procedure, and construction considerations described in the Stormwater Quality Design Manual for the Sacramento Region (latest edition), and shall be reviewed and approved by the City and CCSD.
- The following general landscaping standards also apply to street Landscape Median/Turn Pockets, Landscape Corridors, and private landscaping.**
30. The Elk Grove Municipal Code Chapter 14.10 - Water Efficient Landscape Requirements applies to all Landscape Areas within the Plan Area, including private landscaping.
 31. When the Landscape Area is privately maintained, the landscape architect may deviate from the planting design as shown within the Landscape Corridors, as long as the design consistency is preserved throughout the Plan Area. Any deviation to the planting design shall be approved by the City.
 32. All shrubs and trees shall be located in conformance with City site visibility requirements, view triangle requirements and City Improvement Standards and Details.
 33. Two (2) trees shall be planted on each interior residential lot, with one of the trees designated as a Street Tree. The second tree shall be a Secondary Street Tree or Accent Tree and shall be planted in the residential lot front yard. The Street Tree and Secondary Street Tree/Accent Tree shall be different varieties.
 34. Four (4) trees shall be planted on each corner residential lot, with three of the trees designated as Street Trees. One Street Tree shall be planted in the residential lot front yard while two Street Trees shall be planted in the side yard (when not adjacent to a Community Wall). When a corner residential lot is adjacent to a Community Wall, the Landscape Corridor treatment for that street shall apply. The remaining tree shall be planted in the residential lot front yard and shall be a Secondary Street Tree or Accent Tree. The Street Trees shall be the same variety while the Secondary Street Tree/Accent Tree shall be a different variety.
 35. Trees planted in residential front yards shall be 15-gallon minimum size.

2. Reference Items

Planting and Landscape

Refer to the following chapters of this Manual, as required.

1. Primary Street Tree (refer to Chapter 6)
2. Secondary Street Tree (refer to Chapter 6)
3. Accent Tree (refer to Chapter 6)
4. Landscape Median Tree (refer to Chapter 6)
5. Landscape Median Accent Tree at Landscape Median Nosing (refer to Chapter 6)
6. Large Shrub (refer to Chapter 6)
7. Medium Shrub (refer to Chapter 6)
8. Small Shrub (refer to Chapter 6)
9. Small Shrubs & Groundcover (refer to Chapter 6)
10. Sodded Turf (refer to Chapter 6)
11. Vine (refer to Chapter 6)
12. Landscaping
(Private landscaping designed to the City's satisfaction and maintained by the landowner)
13. Residential Unit Front Yard Landscaping
(Private landscaping designed to the City's satisfaction and maintained by the landowner)
14. Stormwater Planter (refer to this Chapter)

Hardscape and Amenities

Refer to the following chapters of this Manual, as required.

1. Concrete Sidewalk. Score joints on-center spacing equal to width of sidewalk. Expansion joints spacing shall be as required per the Geotechnical Report. If no Geotechnical Report exists, expansion joints shall be every fourth score joint minimum. (Refer to Geotechnical Report for the specific lot within the Plan Area for specific information on slab thickness, reinforcement, etc.)
2. Colored Concrete Enhanced Paving (refer to this Chapter)
3. City of Elk Grove Type 3 Concrete Curb (refer to City of Elk Grove Standard Details)
4. Colored Stamped Concrete Maintenance Safety Strip at Landscape Median/Turn Pocket (refer to this Chapter)
5. Concrete Mowstrip (refer to City of Elk Grove Standard Details)
6. Redwood Headerboard (refer to Chapter 4)
7. Edging for Residential Lots. To be determined by the City.
8. Colored Stamped Asphalt Enhanced Paving Crosswalks (refer to this Chapter)
9. Community Wall with Community Pilasters (refer to Chapter 3)
10. Residential Wood Fence (refer to Chapter 3)
11. Open View Fence (refer to Chapter 3)
12. Neighborhood Entry Monument (refer to Chapter 3)
13. Primary Streetlight (refer to Chapter 4)
14. Pedestrian Scaled Street Light (refer to Chapter 4)
15. Bench (refer to Chapter 4)
16. Trash Receptacle (refer to Chapter 4)
17. Bike Rack (refer to Chapter 4)
18. Tree Grate (refer to Chapter 4)
19. Tree Root Barrier (refer to Chapter 4)
20. City of Elk Grove Visibility Control Area (refer to City of Elk Grove Standard Details)
21. Land Uses
(refer to the SPA, Chapter 2 Land Plan)

CHAPTER 2

STREETS & STREET LANDSCAPING: LANDSCAPE MEDIAN/TURN POCKET DESIGN & STREET MATERIALS

C. LANDSCAPE MEDIAN/TURN POCKET DESIGN & STREET MATERIALS

1. Landscape Median/Turn Pocket

This section specifies the general Landscape Median/Turn Pocket requirements (including nosing) and landscaping improvements on all streets within the Plan Area. The particular street is not relevant to this section as all Landscape Median/Turn Pockets within the Plan Area are 12' in width. All landscape improvements within any Landscape Median/Turn Pocket shall be considered public improvements and shall comply with all City requirements. Additionally, all plant material selected shall be accepted by the CCSD. Refer to General Landscape Plant Palette, Chapter 6, for more information.

Design Elements

Refer to General Standards & Reference Items section this chapter for more information

1. Landscape Median Tree
2. Landscape Median Accent Tree at Landscape Median Nosing
3. Medium Shrub
4. Small Shrub
5. Small Shrubs & Groundcover
- a. Colored Stamped Concrete Maintenance Safety Strip at Landscape Median/Turn Pocket
- b. Colored Stamped Asphalt Enhanced Paving Crosswalk
- c. Tree Root Barrier

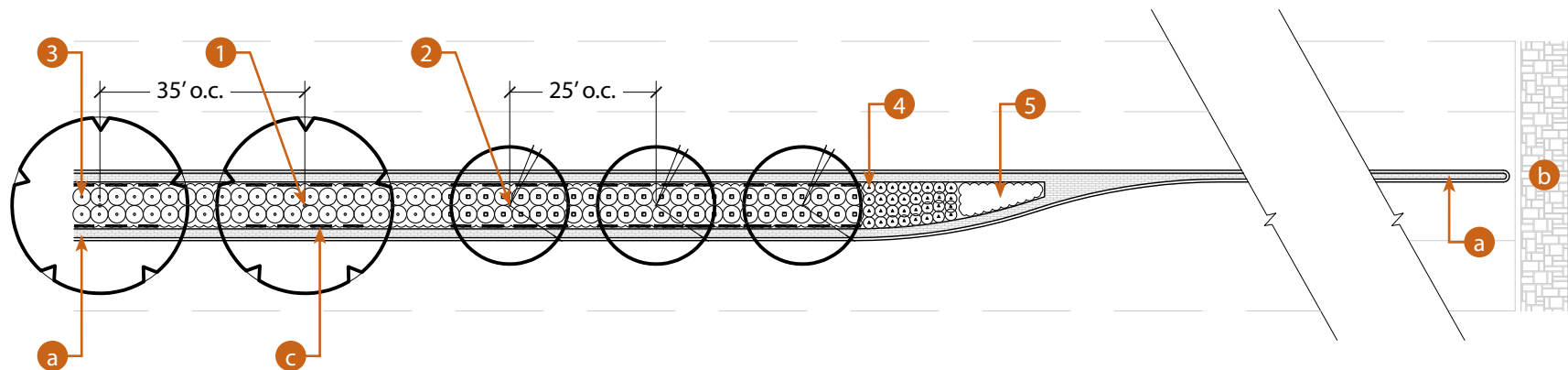

Plan - Not to Scale

2. Colored Stamped Concrete Maintenance Safety Strip at Landscape Median/Turn Pocket

The use of a Colored Stamped Concrete Maintenance Safety Strip is required throughout all Landscape Median/Turn Pockets within the Plan Area (see below). The maintenance safety strip shall be located continuously along both sides of all Landscape Median/Turn Pockets and at all nosing locations where the overall width is 3’ or less as measured from the inside of the curb. The maintenance safety strip shall be a minimum width of 16” and shall abut the back of curb (refer to City of Elk Grove Standard Detail L-26). All concrete shall be integrally colored and stamped, with score joints as required and expansion joints located every 20’ on center spacing. Refer to the Landscape Median/Turn Pocket section in this chapter for more information.

Concrete Color: **5447 Mesa Buff** *
Available from: **Davis Colors***
3700 E. Olympic Blvd. | Los Angeles, CA 90023
Contact: (800) 356-4848

Stamp Pattern: **New Brick - Running Bond Pattern***
Available from: **L.M. Scofield Company***
6533 Bandini Blvd. | Los Angeles, CA 90040
Contact: (800) 800-9900

*= Or approved equivalent

*= Or approved equivalent

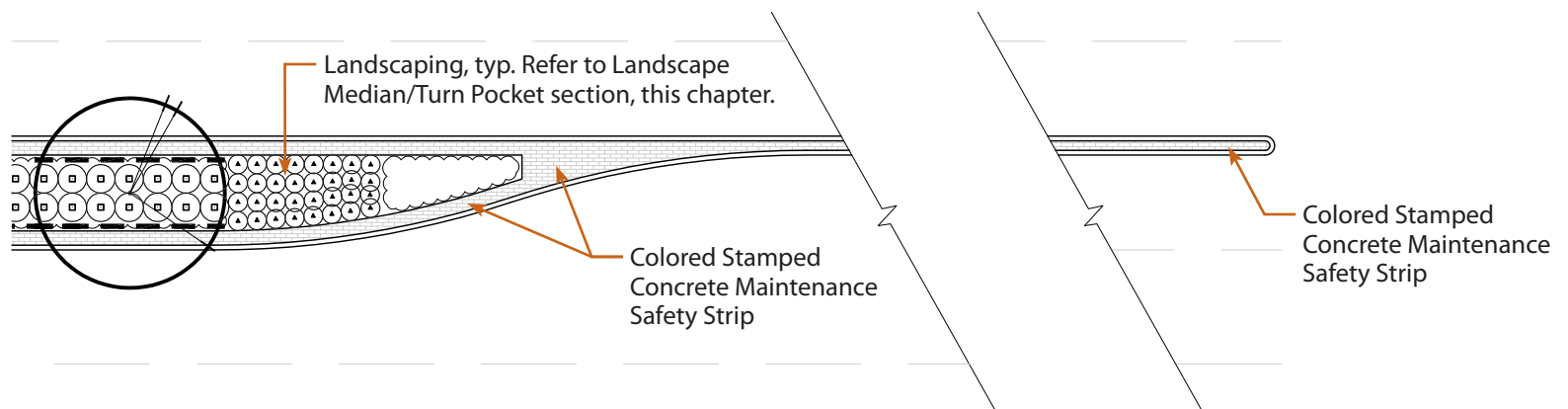

Colored Stamped Concrete Maintenance Safety Strip at Landscape Median/Turn Pocket Plan - Not to Scale

CHAPTER 2

STREETS & STREET LANDSCAPING: LANDSCAPE MEDIAN/TURN POCKET DESIGN & STREET MATERIALS

3. Colored Concrete Enhanced Paving

The use of colored concrete enhanced paving is required at the corner of all intersections at Kammerer Road as well as all Arterial Streets. Additionally, enhanced paving may be required along Collector Roads and entrances to Office and Light Industrial/Flex land uses as required by the City. Enhanced paving areas shall be sized as shown on the Enhanced Paving Plan below. Enhanced paving shall be integrally colored concrete, with diagonal scoring at 4'-0" on center spacing. Install expansion joints as required by the City.

Concrete Color: 5447 Mesa Buff - Medium Broom Finish*

Available from: Davis Colors*

3700 E. Olympic Blvd. | Los Angeles, CA 90023

Contact: (800) 356-4848

* = Or approved equivalent

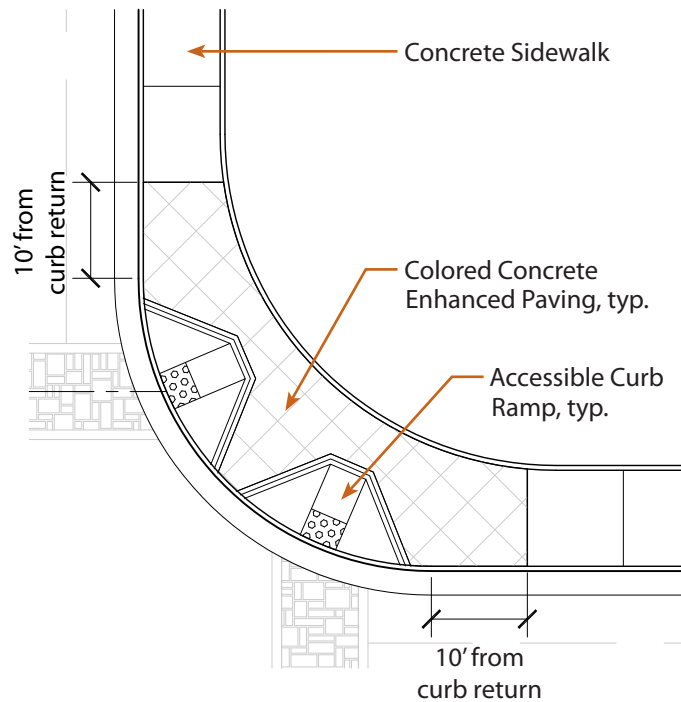

Enhanced Paving Plan - Not to Scale



Example: 5447 Mesa Buff Concrete Color with Medium Broom Finish*

4. Colored Stamped Asphalt Enhanced Paving Crosswalks

The use of stamped asphalt enhanced paving crosswalks is required at all accessible curb ramp locations on Kammerer Road as well as all Arterial Streets. Similarly, enhanced paving crosswalks may also be required at greenway and drainage area access points at Collector Streets and Local Residential Streets, as well as the entrances to Office and Light Industrial/Flex land uses as required by the City. Enhanced paving crosswalks shall be sized as shown on the Colored Stamped Asphalt Enhanced Crosswalk Paving Plan below.

Surfacing: **Traffic Pattern XD Stamped Asphalt Surfacing System***
 Pattern: **Slate***
 Color: **Cocoa***
 Available from: **Ennis-Flint**
 115 Todd Court, PO Box 160 | Thomasville, NC 27360
 Contact: (800) 331-8118

12" crosswalk markings shall be painted and constructed with white thermoplastic material to the specifications set forth in Chapter 3 and Chapter 7 of the California Manual on Uniform Traffic Control Devices (California MUTCD), latest edition.

* = Or approved equivalent

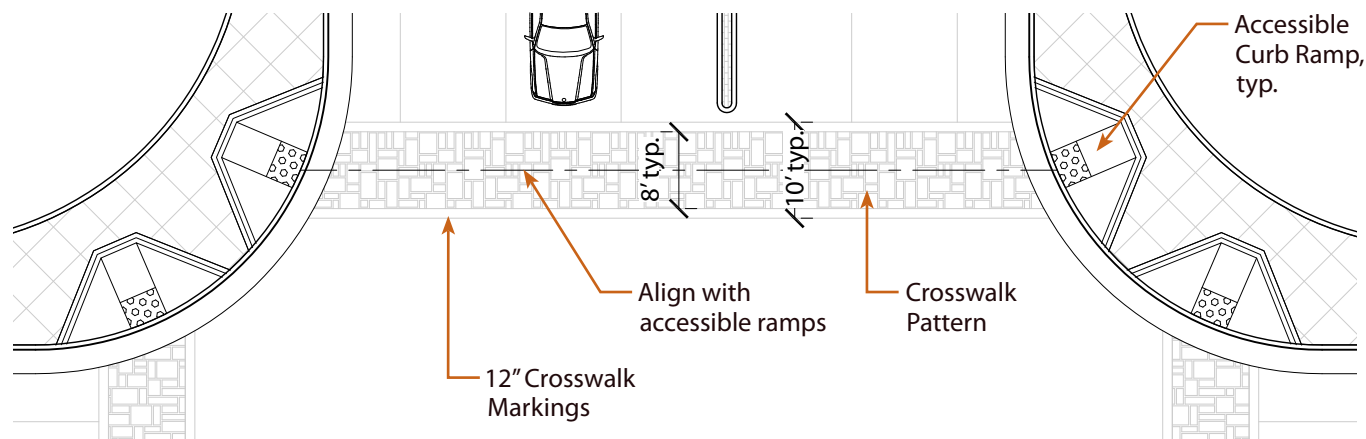

Colored Stamped Asphalt Enhanced Paving Crosswalk Plan - Not to Scale

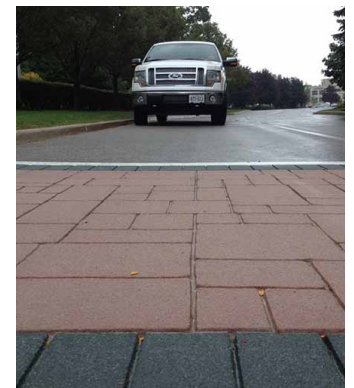

**Example: Traffic Pattern XD
Slate Pattern**

CHAPTER 2

STREETS & STREET LANDSCAPING: LANDSCAPE CORRIDORS PLAN

D. LANDSCAPE CORRIDORS

1. Landscape Corridors Plan

The Landscape Corridors Plan illustrates where the various street development standards and Landscape Corridors exist within the Plan Area.

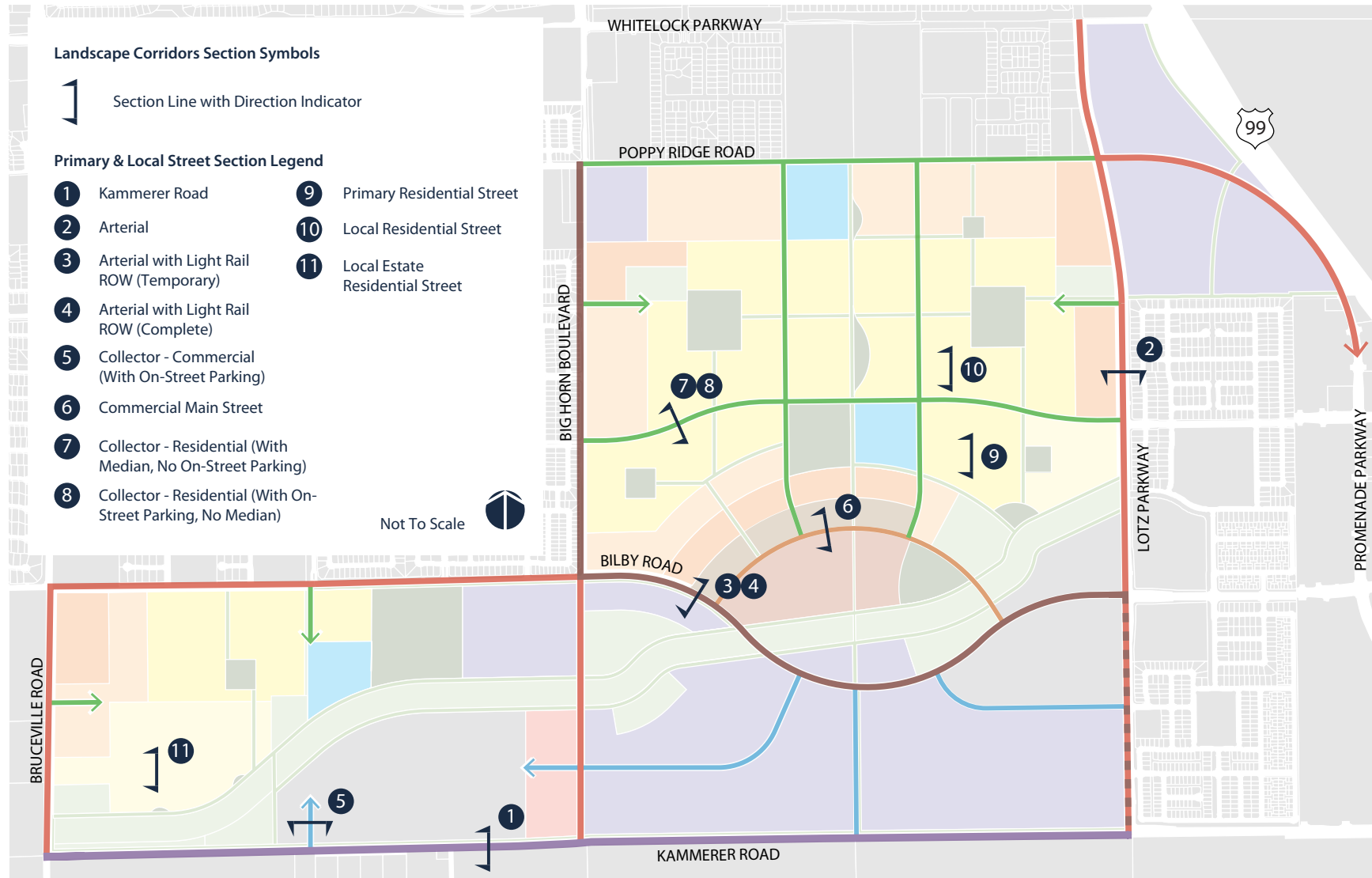

2. Kammerer Road

Kammerer Road features a minimum 36' wide Landscape Area as measured from the back of curb to the property line. The south side of Kammerer Road shall be installed in phases as required by the City. For the purposes of this street, the landscape requirements are designed for the full width of the Right of Way (ROW) including the 36' Landscape Areas located on both side of the street.

Design Elements

Refer to General Standards & Reference Items section this chapter for more information.

- | | |
|--|--|
| 1. Primary Street Tree | a. Kammerer Road |
| 2. Secondary Street Tree or Accent Tree | b. Concrete Sidewalk |
| 3. Landscape Median Tree | c. City of Elk Grove Type 3 Concrete Curb |
| 4. Landscape Median Accent Tree at Landscape Median Nosing (not shown) | d. Colored Stamped Concrete Maintenance Safety Strip at Landscape Median/Turn Pocket |
| 5. Large Shrub (not shown) | e. Primary Streetlight |
| 6. Medium Shrub | f. Bench |
| 7. Small Shrubs & Groundcover | g. Trash Receptacle |
| | h. Lighted Bollard |
| | i. Tree Root Barrier |
| | j. Concrete Mowstrip (Landscape Area Limit) |

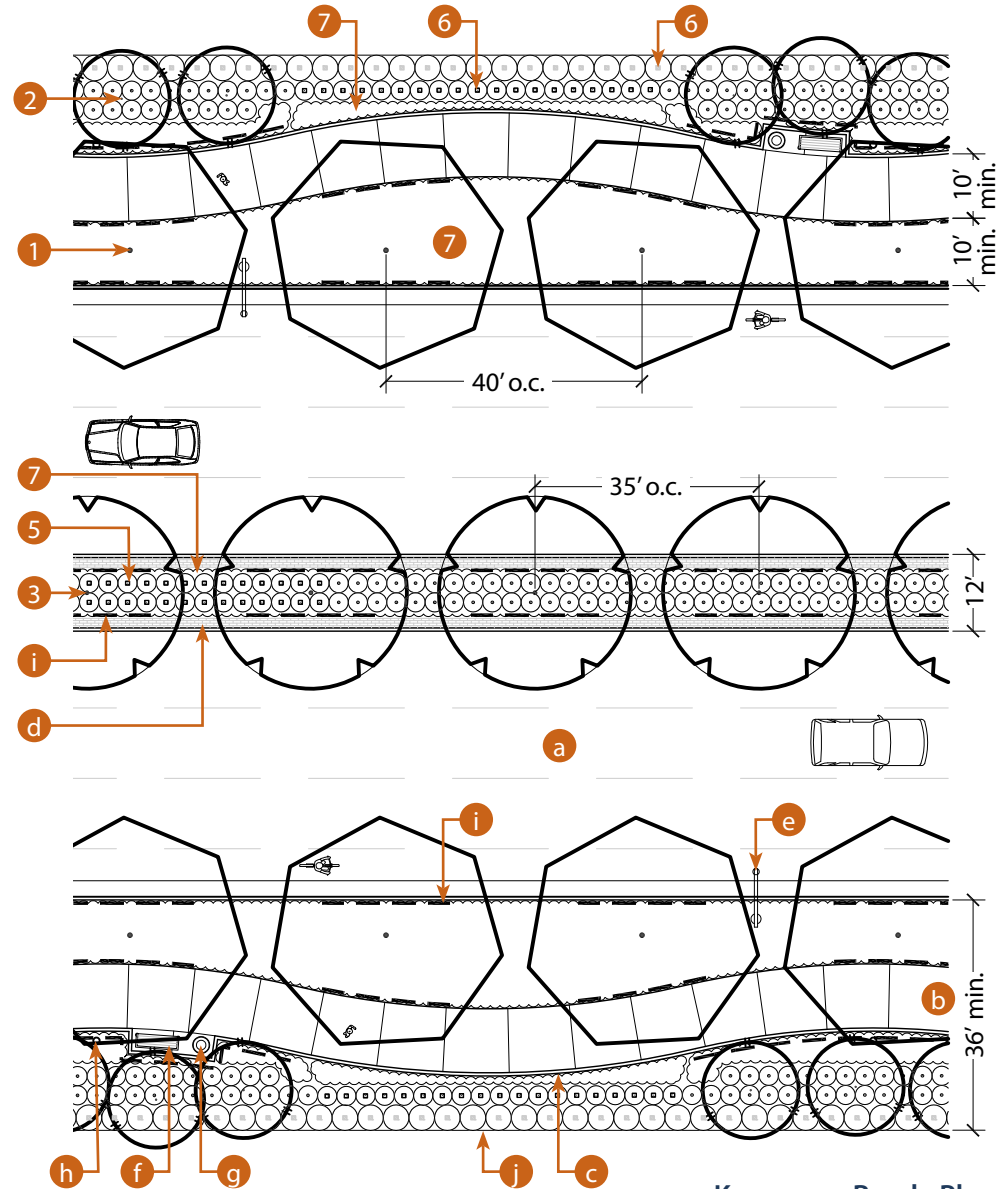

Kammerer Road - Plan
Not to Scale

CHAPTER 2

STREETS & STREET LANDSCAPING: LANDSCAPE CORRIDORS

3. Arterial

Arterial Streets feature a minimum 24' wide Landscape Area as measured from the back of curb at ROW to the property line. When the 24' wide Landscape Area is adjacent to single-family residential, it shall be considered public improvement and shall comply with all City requirements. However, when adjacent to any other land use, the 24' Landscape Area shall be private landscaping designed to the City's satisfaction and maintained by the landowner.

Design Elements

Refer to General Standards & Reference Items section this chapter for more information.

- | | |
|--|---|
| 1. Primary Street Tree | a. Arterial Street |
| 2. Accent Tree (not shown) | b. Concrete Sidewalk |
| 3. Landscape Median Tree | c. City of Elk Grove Type 3 Concrete Curb |
| 4. Landscape Median Accent Tree at Landscape Median Nosing (not shown) | d. Colored Stamped Concrete Maintenance Safety Strip at Landscape Median/ Turn Pocket |
| 5. Large Shrub (not shown) | e. Community Wall with Community Pilasters |
| 6. Medium Shrub | f. Primary Streetlight |
| 7. Small Shrub (not shown) | g. Bench (not shown) |
| 8. Small Shrubs & Groundcover | h. Trash Receptacle (not shown) |
| 9. Vine | i. Lighted Bollard |
| | j. Tree Root Barrier |
| | k. Concrete Mowstrip (Landscape Area Limit) |

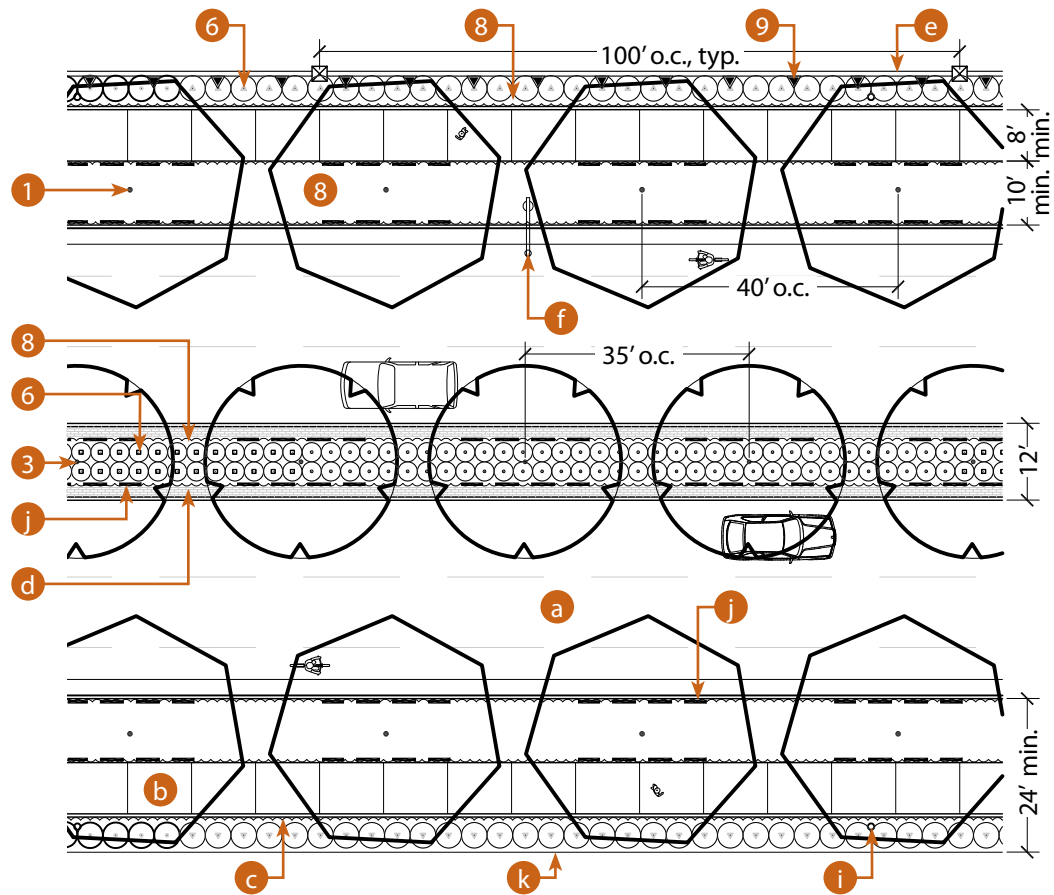

Arterial - Plan

Not to Scale

4. Arterial with Transit Corridor (Temporary Landscaping)

Arterial Streets with a transit corridor feature a minimum 24' wide Landscape Area as measured from the back of curb ROW to the property line, as well as 40' right-of-way on one side of the street for a future transit connection. The 24' Landscape Area adjacent to the 40' transit corridor shall always be considered public improvements and shall comply with all City requirements. The opposing 24' Landscape Area, when adjacent to single family residential, shall be considered public improvements and shall comply with all City requirements. However, when adjacent to any other land use, this 24' Landscape Area shall be private landscaping designed to the City's satisfaction and maintained by the landowner. In advance of the transit facility, the 40' transit corridor shall be landscaped to the satisfaction of the City. No fencing shall be installed between the 24' Landscape Area and the 40' transit corridor until the transit connection is completed. Depending on the land use adjacent to the transit corridor, either a Open View Fence or Community Wall shall be located at the property line adjacent to the transit corridor. Residential uses adjacent to the corridor shall install a Community Wall along the shared property line as part of their development. All other uses shall install an Open View Fence. All fencing and walls shall be consistent with the design requirements set forth in the Walls, Fences and Entry Monuments chapter (refer to Chapter 3).

Design Elements

Refer to General Standards & Reference Items section this chapter for more information.

- | | | |
|--|---|---|
| 1. Primary Street Tree | a. Arterial Street with Transit Corridor | Pilasters (not shown) |
| 2. Landscape Median Tree | b. Concrete Sidewalk | f. Primary Streetlight |
| 3. Landscape Median Accent Tree at Landscape Median Nosing (not shown) | c. City of Elk Grove Type 3 Concrete Curb | g. Bench |
| 4. Large Shrub | d. Colored Stamped Concrete Maintenance Safety Strip at Landscape Median/ Turn Pocket | h. Trash Receptacle |
| 5. Medium Shrub | e. Open View Fence (shown) or Community Wall with Community | i. Lighted Bollard |
| 6. Small Shrubs & Groundcover | | j. Tree Root Barrier |
| | | k. Redwood Header |
| | | l. Concrete Mowstrip (Landscape Area Limit) |
| | | m. Light Rail Transit Corridor (future development) |

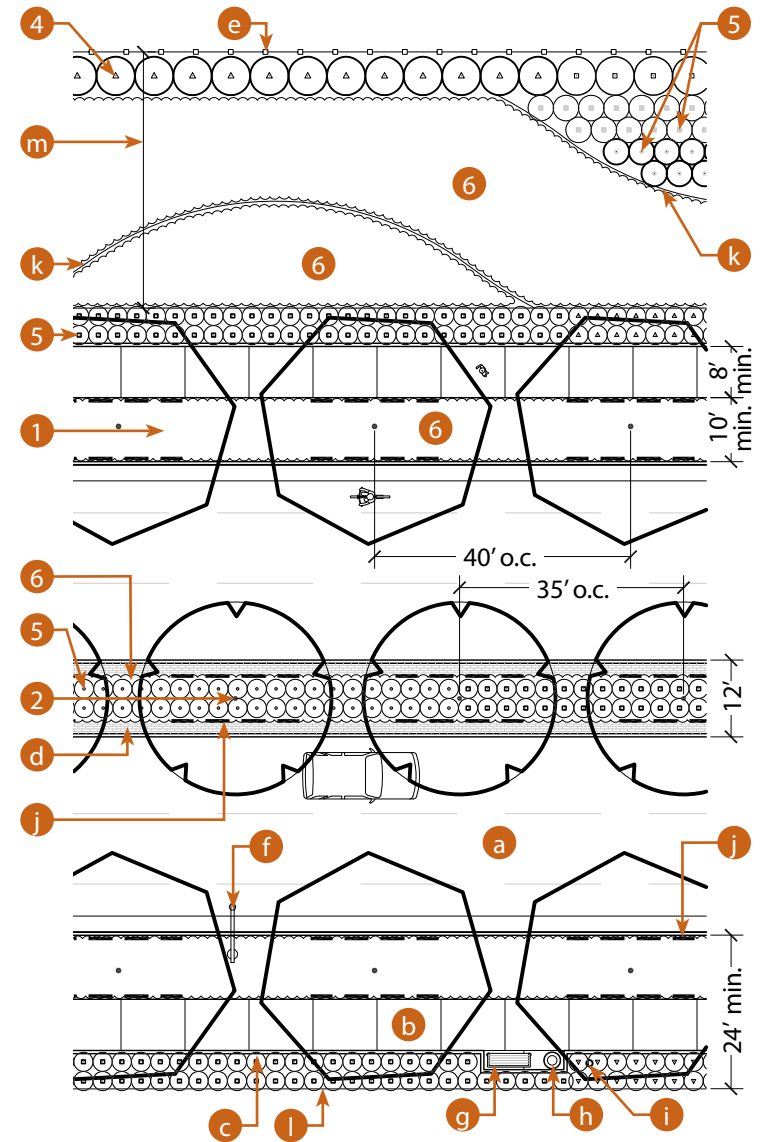

Arterial with Transit Corridor
(Temporary Landscaping) - Plan
Not to Scale

CHAPTER 2

STREETS & STREET LANDSCAPING: LANDSCAPE CORRIDORS

5. Arterial with Transit Corridor (Completed Transit Connection)

Arterial Streets with a transit corridor feature a minimum 24' wide Landscape Area as measured from the back of curb ROW to the property line, as well as 40' right-of-way on one side of the street for a future transit connection. The 24' Landscape Area adjacent to the 40' transit corridor shall always be considered public improvements and shall comply with all City requirements. The opposing 24' Landscape Area, when adjacent to single family residential, shall be considered public improvements and shall comply with all City requirements. However, when adjacent to any other land use, this 24' Landscape Area shall be private landscaping designed to the City's satisfaction and maintained by the landowner. Upon development of the transit system, an Open View Fence shall be installed along the street side of the transit corridor. Depending on the land use adjacent to the transit corridor, either an Open View Fence or Community Wall shall be located at the property line adjacent to the transit corridor. Residential uses adjacent to the corridor shall install a Community Wall along the shared property line as part of their development. All other uses shall install an Open View Fence. All fencing and walls shall be consistent with the design requirements set forth in the Walls, Fences and Entry Monument chapter (refer to Chapter 3).

Design Elements

Refer to General Standards & Reference Items section this chapter for more information.

- | | | |
|--|---|---|
| 1. Primary Street Tree | a. Arterial Street with Transit Corridor | f. Primary Streetlight |
| 2. Landscape Median Tree | b. Concrete Sidewalk | g. Bench |
| 3. Landscape Median Accent Tree at Landscape Median Nosing (not shown) | c. City of Elk Grove Type 3 Concrete Curb | h. Trash Receptacle |
| 4. Medium Shrub | d. Colored Stamped Concrete Maintenance Safety Strip at Landscape Median/ Turn Pocket | i. Lighted Bollard |
| 5. Small Shrubs & Groundcover | e. Open View Fence (shown) or Community Wall with Community Pilaster (not shown) | j. Tree Root Barrier |
| | | k. Open View Fence |
| | | l. Concrete Mowstrip (Landscape Area Limit) |
| | | m. Light Rail Transit Corridor (future development) |

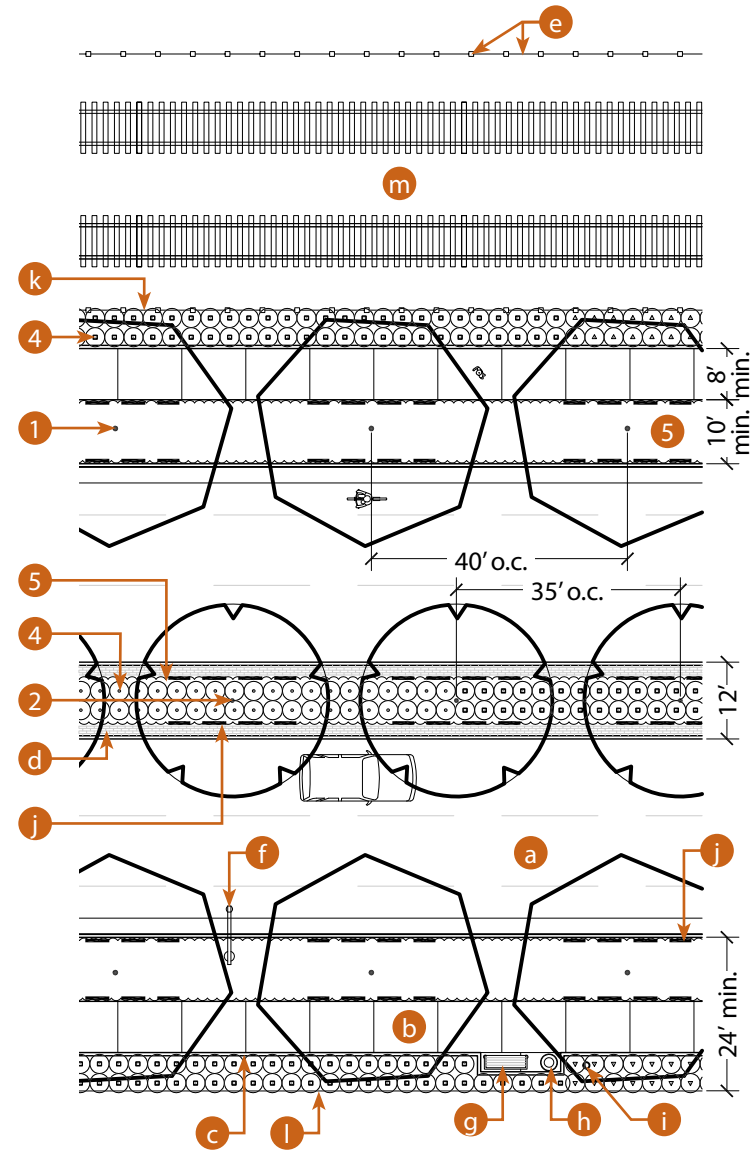

**Arterial with Transit Corridor
(Completed Transit Connection) - Plan**

Not to Scale

6. Collector - Commercial

Collector - Commercial Streets can be designed with or without on-street parking as approved by the City. For the purposes of this Manual, Collector - Commercial Streets are shown with on-street parking. Collector Commercial streets feature a minimum 24' wide Landscape Area as measured from the back of curb at ROW. As Collector - Commercial Streets will only be adjacent to Office, Light Industrial/Flex and Commercial land uses, both 24' wide Landscape Areas shall be private landscaping designed to the City's satisfaction and maintained by the landowner.

Design Elements

Refer to General Standards & Reference Items section this chapter for more information.

- | | |
|--|--|
| 1. Primary Street Tree | a. Collector - Commercial (with On-Street Parking) |
| 2. Secondary Street Tree or Accent Tree (not shown) | b. Concrete Sidewalk |
| 3. Landscape Median Tree | c. City of Elk Grove Type 3 Concrete Curb |
| 4. Landscape Median Accent Tree at Landscape Median Nosing (not shown) | d. Colored Stamped Concrete Maintenance Safety Strip at Landscape Median/Turn Pocket |
| 5. Large Shrub (not shown) | e. Primary Streetlight |
| 6. Medium Shrub (not shown) | f. Pedestrian-Scaled Street Light Located Along Sidewalk (not shown) |
| 7. Small Shrub (not shown) | g. Tree Root Barrier |
| 8. Small Shrubs and Groundcovers | |

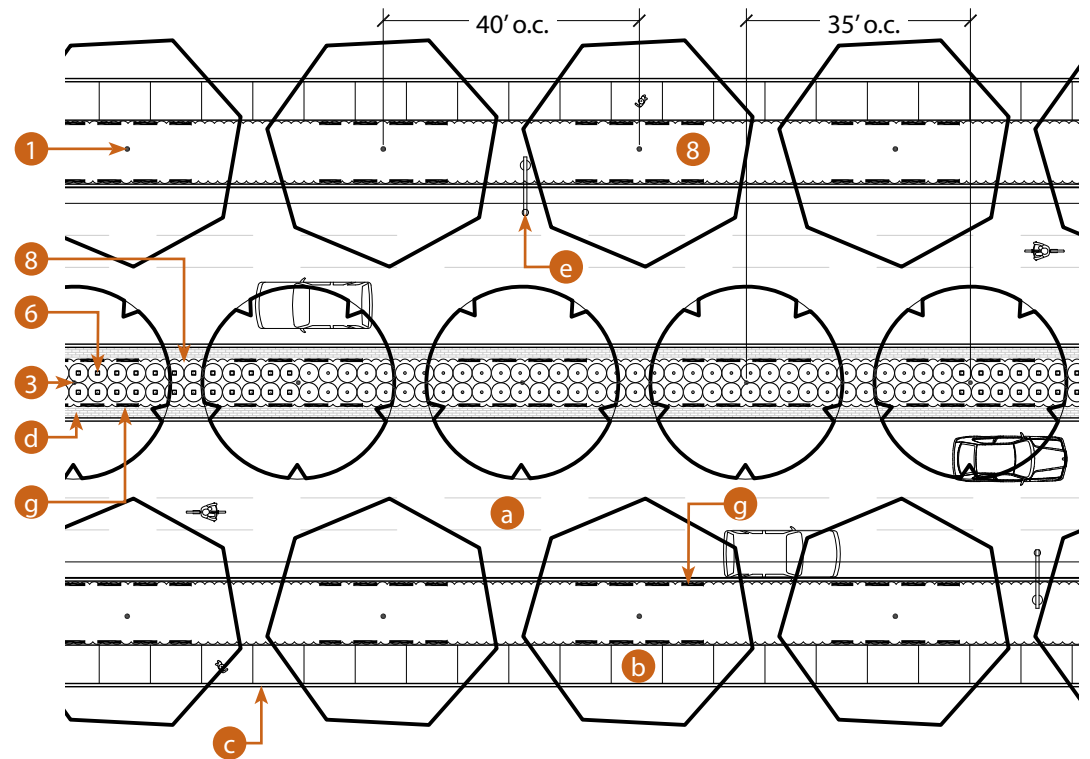

Collector - Commercial - Plan

Not to Scale

CHAPTER 2

STREETS & STREET LANDSCAPING: LANDSCAPE CORRIDORS

7. Commercial Main Street

There is one Commercial Main Street located within the Plan Area. This street provides for a variety of travel modes, including vehicular, bicycle and pedestrian and is predominately adjacent to Mixed-Use Residential and Mixed-Use Village Center. Due to the proximity to Mixed-Use development, this street emphasizes a pedestrian scaled environment with wide sidewalks, site furnishings and street trees. Additionally, as the Commercial Main Street will only be adjacent to Mixed-Use land use (excluding park land use), any and all Landscape Areas, planting media, and site furnishings shall be private landscaping designed to the City's satisfaction, reviewed and approved by the CCSA, and maintained by the landowner or a maintenance association.

Design Elements

Refer to General Standards & Reference Items section this chapter for more information.

- | | |
|---|--|
| 1. Primary Street Tree | a. Commercial Main Street |
| 2. Secondary Tree or Accent Tree (not shown) | b. Bulbout (not shown) |
| 3. Landscape Median Tree | c. Concrete Sidewalk |
| 4. Landscape Median Accent Tree at Landscape Median | d. City of Elk Grove Type 3 Concrete Curb (not shown) |
| 5. Large Shrub (not shown) | e. Colored Stamped Concrete Maintenance Safety Strip at Landscape Median/Turn Pocket |
| 6. Medium Shrub | f. Pedestrian-Scaled Street Light |
| 7. Small Shrubs and Groundcover | g. Bench |
| | h. Trash Receptacle |
| | i. Bike Rack (not shown) |
| | j. Tree Grate |
| | k. Tree Root Barrier (in tree well) |
| | k. Stormwater Planter (not shown) |

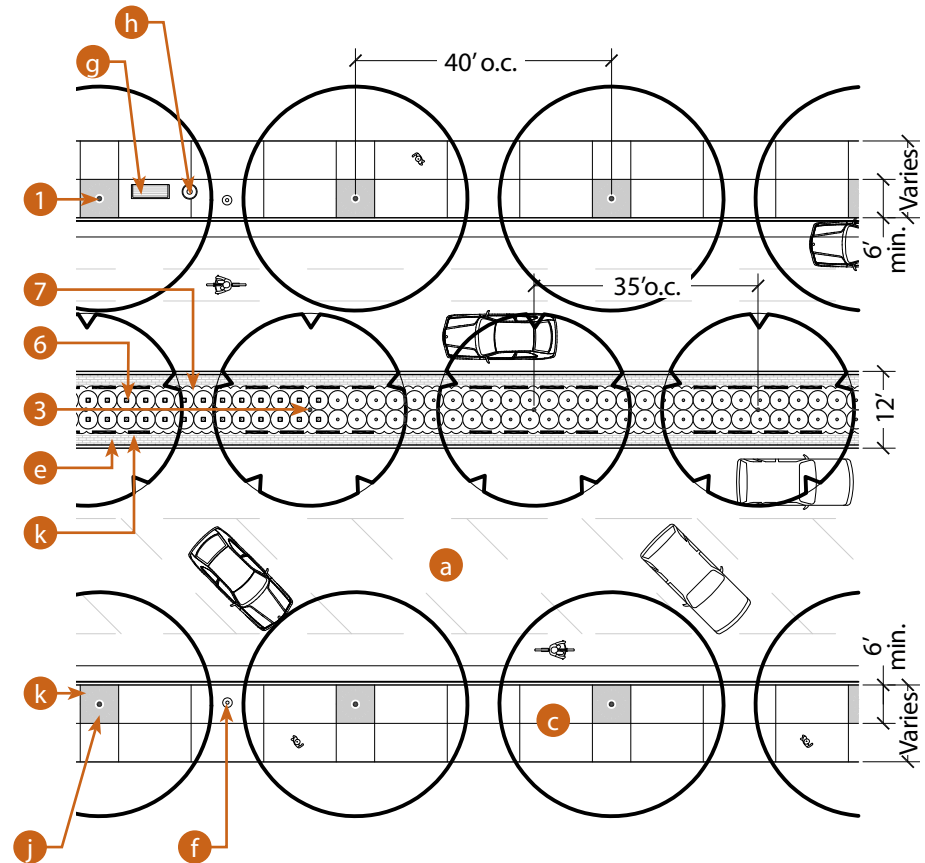

Commercial - Plan
Not to Scale

8. Collector - Residential (With Median, No On-Street Parking)

Collector - Residential Streets can be designed with or without a Landscape Median/Turn Pocket, and with or without on-street parking as approved by the City. For the purposes of this section, Collector - Residential streets are shown with a Landscape Median/Turn Pocket and no on-street parking. When single-family residential houses back onto the street, a Community Wall is required at the property line and an additional 8' Landscape Area shall be required to provide screening of the Community Wall. In this application, all landscape improvements including the 8' Landscape Area and the landscaping within the separated sidewalk shall be considered public improvements and shall comply with all City requirements. When single-family residential houses front the street, the entire Landscape Area on that side of the street shall be private landscaping designed to the City's satisfaction and maintained by the landowner.

Design Elements

Refer to General Standards & Reference Items section this chapter for more information.

- | | |
|--|---|
| 1. Primary Street Tree | a. Collector - Residential Street |
| 2. Secondary Street Tree or Accent Tree (not shown) | b. Concrete Sidewalk |
| 3. Landscape Median Tree | c. City of Elk Grove Type 3 Concrete Curb |
| 4. Landscape Median Accent Tree at Landscape Median Nosing (not shown) | d. Colored Stamped Concrete Maintenance Safety Strip at Landscape Median/Turn Pocket |
| 5. Medium Shrub | e. Community Wall with Community Pilasters or Concrete Mowstrip (as determined by the City) |
| 6. Small Shrub (not shown) | f. Primary Streetlight |
| 7. Small Shrubs & Groundcover | g. Tree Root Barrier |
| 8. Vine | h. Additional Landscape Area (as required) |
| 9. Landscaping | i. City of Elk Grove Visibility Control Area, typ. |

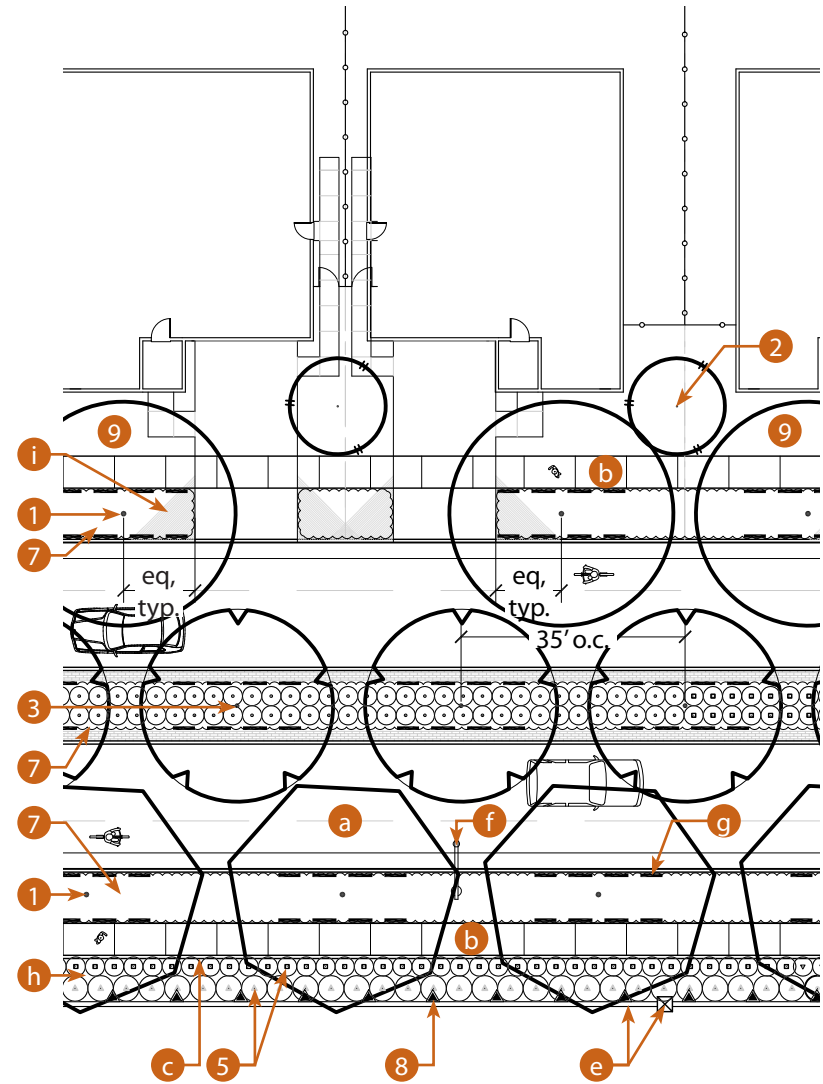

**Collector - Residential
(With Median, No On-Street Parking) - Plan**
Not to Scale

9. Collector - Residential (With On-Street Parking, No Median)

Collector - Residential Streets can be designed with or without a Landscape Median/Turn Pocket, and with or without on-street parking as approved by the City. For the purposes of this section, Collector Residential streets are shown with on-street parking and without a Landscape Median/Turn Pocket. When single-family residential houses back onto the street, a Community Wall is required at the property line and an additional 8' Landscape Area shall be required to provide screening of the Community Wall. In this application, all landscape improvements including the 8' Landscape Area and the landscaping within the separated sidewalk shall be considered public improvements and shall comply with all City requirements. When single-family residential houses front the street, the entire Landscape Area on that side of the street shall be private landscaping designed to the City's satisfaction and maintained by the landowner.

Design Elements

Refer to General Standards & Reference Items section this chapter for more information.

- | | |
|---|---|
| 1. Primary Street Tree | a. Collector - Residential Street |
| 2. Secondary Street Tree or Accent Tree | b. Bulbout (not shown) |
| 3. Groundcover | c. Concrete Sidewalk |
| 4. Landscaping | d. City of Elk Grove Type 3 Concrete Curb (not shown) |
| | e. Primary Streetlight |
| | f. Tree Root Barrier |
| | g. City of Elk Grove Visibility Control Area, typ. |

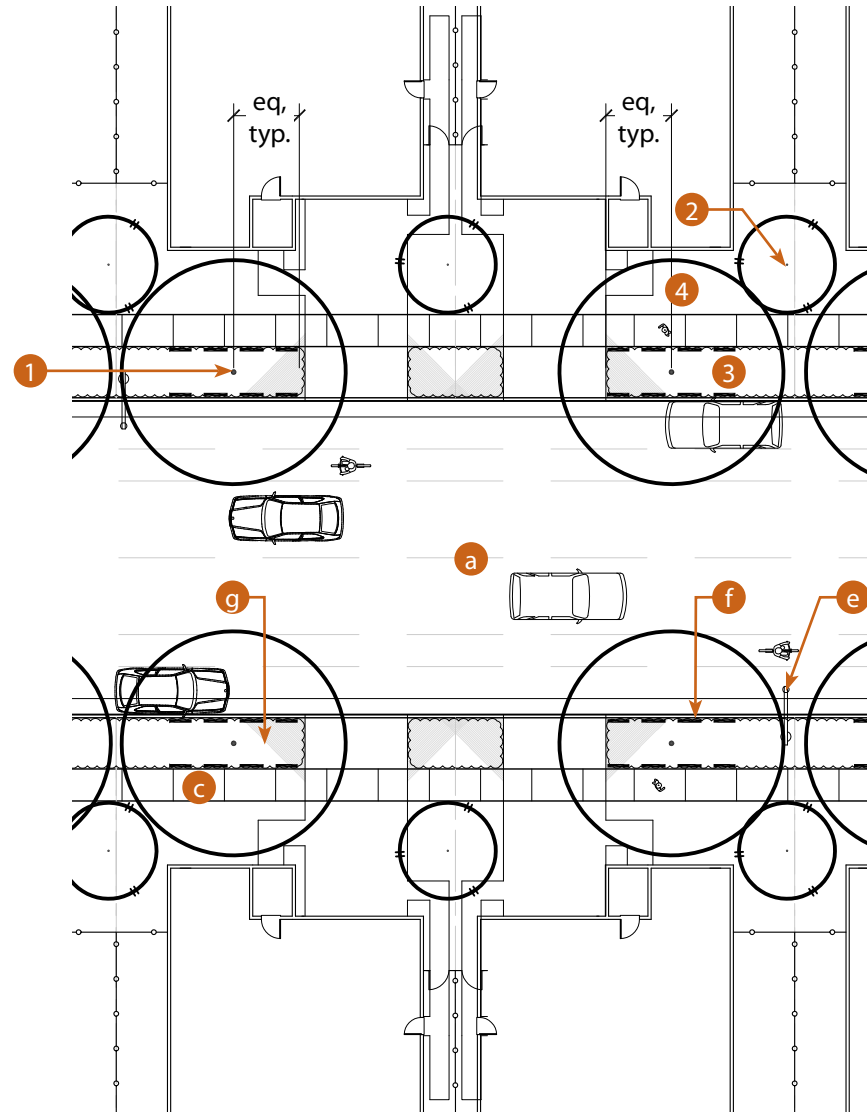

**Collector - Residential
(With On-Street Parking, No Median) - Plan**
Not to Scale

10. Primary Residential Street

Primary Residential Streets provide access into and through the neighborhoods. When single-family residential houses back onto the street, a Community Wall is required at the property line and an additional 8' Landscape Area shall be required to provide screening of the Community Wall. In this application, all landscape improvements including the 8' Landscape Area and the landscaping within the separated sidewalk shall be considered public improvements and shall comply with all City requirements. When single-family residential houses front the street, the entire Landscape Area on that side of the street shall be private landscaping designed to the City's satisfaction and maintained by the landowner.

Design Elements

Refer to General Standards & Reference Items section this chapter for more information.

- | | |
|---|---|
| 1. Primary Street Tree | a. Primary Residential Street |
| 2. Secondary Street Tree or Accent Tree | b. Bulbout (not shown) |
| 3. Small Shrubs & Groundcover | c. Concrete Sidewalk |
| 4. Landscaping | d. City of Elk Grove Type 3 Concrete Curb (not shown) |
| | e. Primary Streetlight |
| | f. Tree Root Barrier |
| | g. City of Elk Grove Visibility Control Area, typ. |

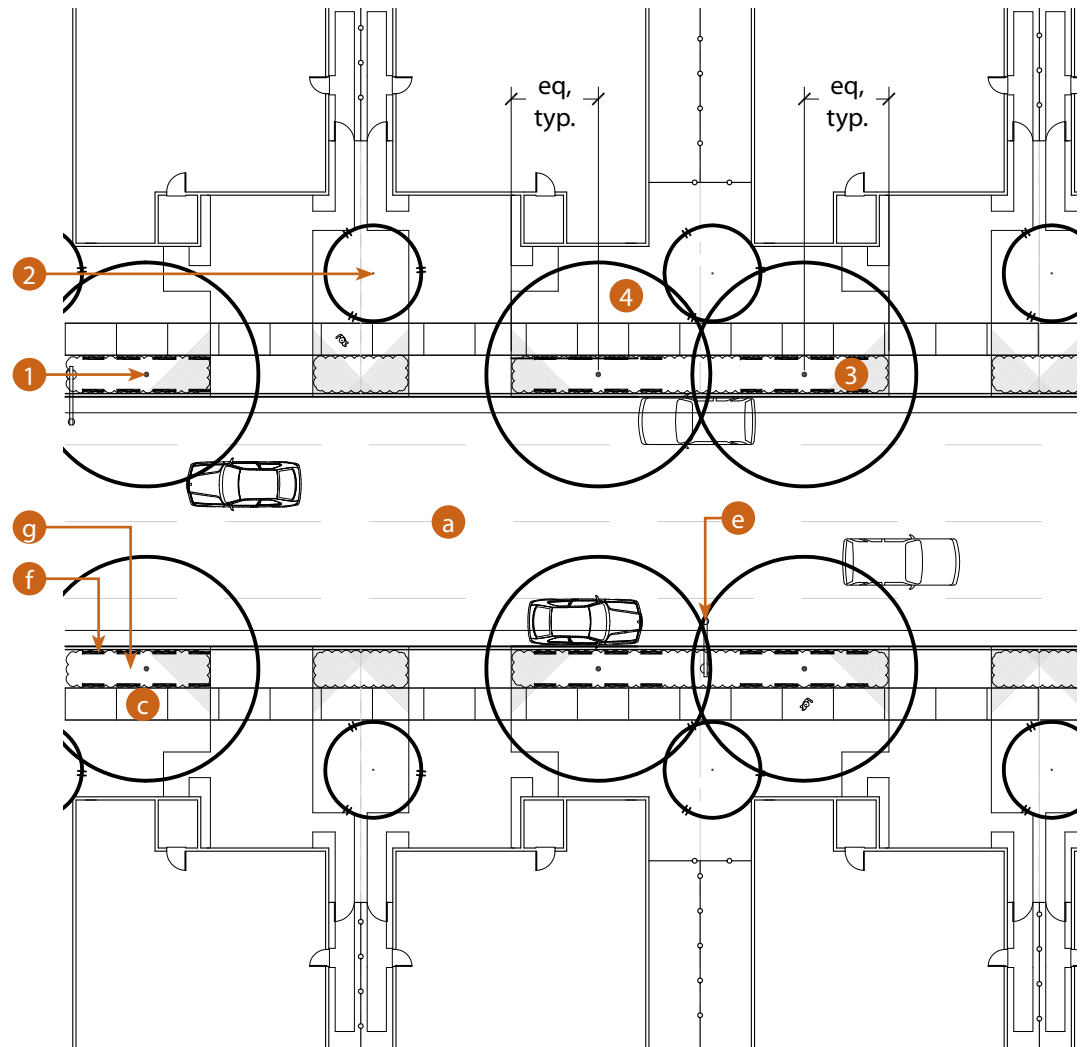

Primary Residential Street -Plan

Not to Scale

CHAPTER 2

STREETS & STREET LANDSCAPING: LANDSCAPE CORRIDORS

11. Local Residential Street

Local residential streets provide access into and through the neighborhoods. Only single-family residential houses will front a local residential street. Therefore, all landscape improvements shall be private landscaping designed to the City's satisfaction and maintained by the landowner.

Design Elements

Refer to General Standards & Reference Items section this chapter for more information.

- | | |
|---|--|
| 1. Primary Street Tree | a. Local Residential Street |
| 2. Secondary Street Tree or Accent Tree | b. Concrete Sidewalk |
| 3. Landscaping | c. Primary Streetlight |
| | d. Tree Root Barrier |
| | e. City of Elk Grove Visibility Control Area, typ. |

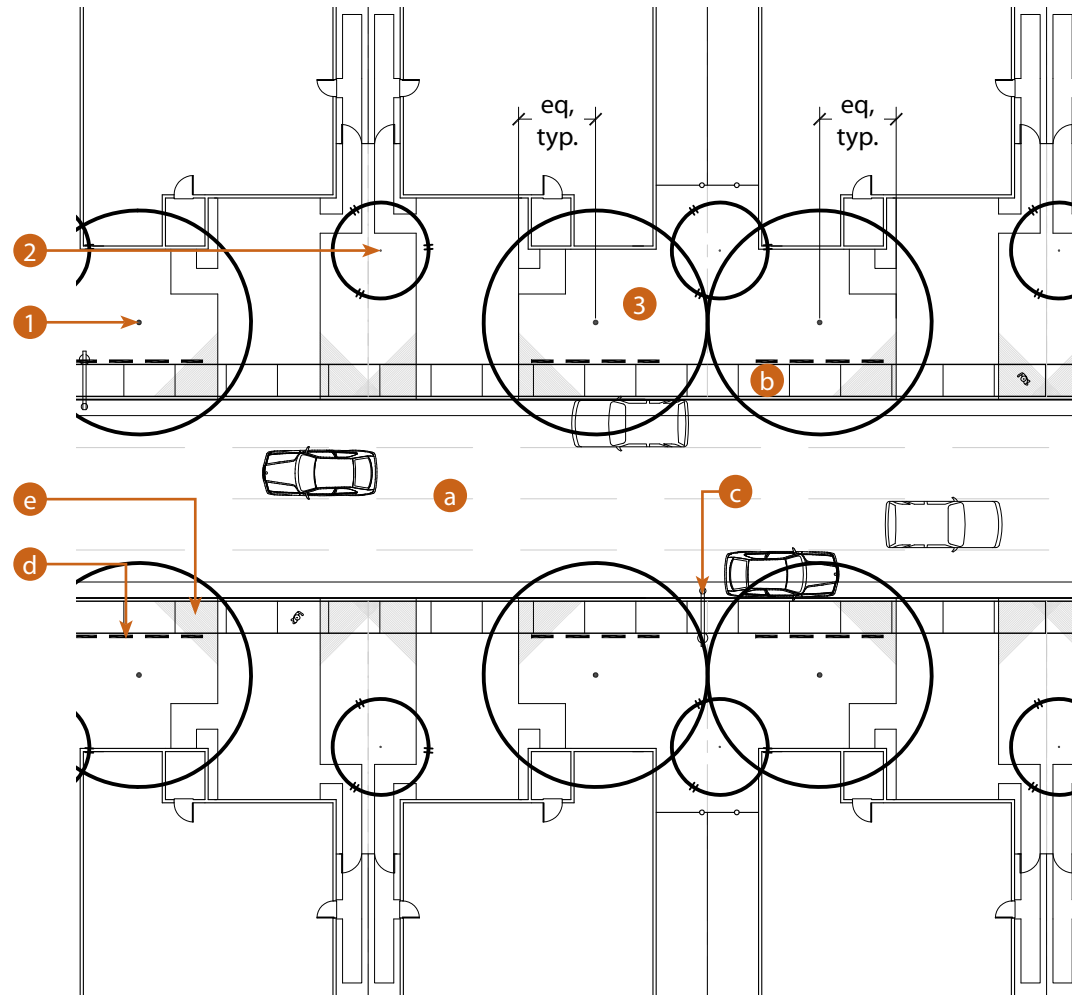

Local Residential Street - Plan

Not to Scale

12. Local Estate Residential Street

Local Estate Residential streets provide access into and through estate residential neighborhoods. It differs from other local street types in that drainage is facilitated through roadside bioswales. The unpaved shoulder shall be decomposed granite or similar low maintenance material. The unpaved shoulder material shall be consistent across all residential lots as required by the City. The bioswale shall be landscaped with grasses appropriate for potential periods of inundation, common in this type of application. All landscape improvements shall be private landscaping designed to the City’s satisfaction and maintained by the landowner even within the ROW.

Design Elements

Refer to General Standards & Reference Items section this chapter for more information.

- | | |
|---|--|
| 1. Primary Street Tree | a. Local Estate Residential Street |
| 2. Secondary Street Tree or Accent Tree | b. Concrete Sidewalk |
| 3. Sodded Bioswale Grass | c. Primary Streetlight (not shown) |
| 4. Landscaping | d. Tree Root Barrier |
| | e. City of Elk Grove Visibility Control Area, typ. |

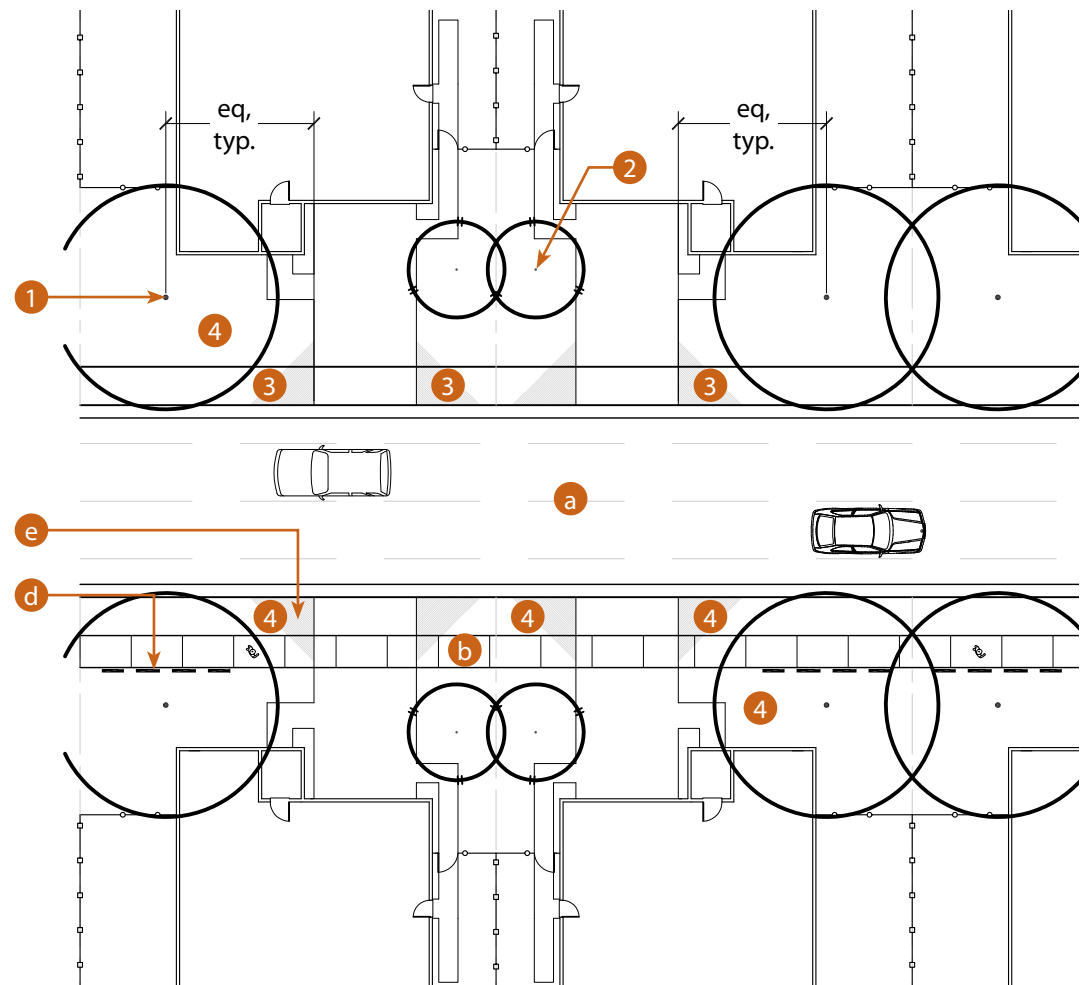

Local Estate Residential Street - Plan

Not to Scale

CHAPTER 2

STREETS & STREET LANDSCAPING: RESIDENTIAL YARDS

E. RESIDENTIAL UNIT FRONT YARDS

Residential Unit Front Yards are a critical component to the overall theme of the Plan Area and community. The individual residential unit improvements specified in this section are outside of the ROW for each associated street. Therefore, all landscape improvements shall be private landscaping designed to the City's satisfaction and maintained by the landowner. In this section, an example of both an interior lot and corner lot has been provided. The standards in this chapter regarding Residential Unit Front Yard landscape are the minimum requirements. The Residential Unit Builder/designer may deviate from the planting design as long as the design consistency is preserved throughout the Plan Area. Any deviation to the planting design shall be approved by the City.

In addition to the general landscaping requirements listed in this chapter's General Standards, the following landscape standards specifically apply to Residential Unit Front Yards:

1. A trash receptacle storage area shall be provided behind the front yard Residential Wood Fence within the homeowner's private side-yard. This storage area shall be constructed out of concrete to match the side yard walkway, including finish and color. The minimum trash receptacle storage area dimensions are 10' long x 3' wide and shall be consistent across all Residential Units within the Plan Area.
2. Concrete scoring of all Residential Unit walkways and driveways shall be determined by the Landowner or Residential Unit Builder and shall be approved by the City.

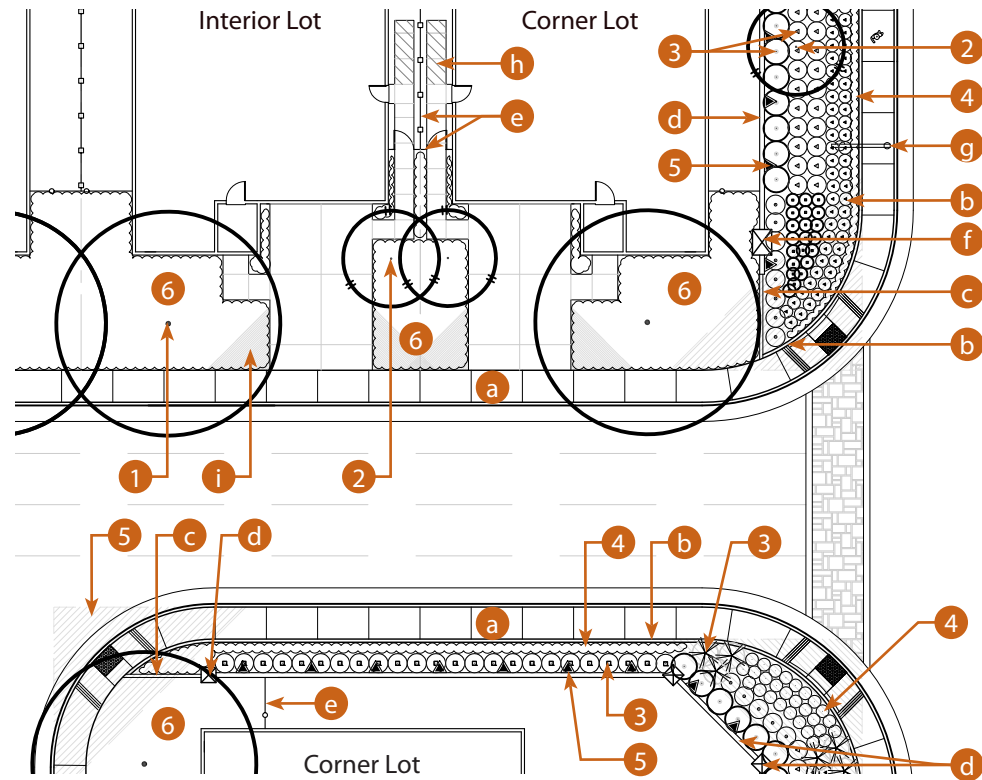

Residential Unit Front Yards - Plan

Not to Scale

Design Elements

Refer to General Standards & Reference Items section this chapter for more information

- | | | |
|--|---|--|
| 1. Primary Street Tree | a. Concrete Sidewalk | f. Neighborhood Entry Monument (Optional) |
| 2. Secondary Street Tree or Accent Tree | b. City of Elk Grove Type 3 Concrete Curb | g. Primary Streetlight |
| 3. Large & Medium Shrub | c. Edging for Residential Lots | h. Trash Receptacle Storage Area (10' x 3') |
| 4. Small & Groundcover | d. Community Wall with Community Pilaster or Residential Wood Fence | i. City of Elk Grove Visibility Control Area, typ. |
| 5. Vine | e. Residential Wood Fence | j. Tree Root Barrier (not shown) |
| 6. Residential Unit Front Yard Landscaping | | |

F. BRIDGES

1. Vehicular Bridge

There are vehicular bridges located on Bilby Road, the Commercial Main Street, and Big Horn Blvd. Final design and engineering requirements of the vehicular bridges shall be determined by the City.

The vehicular bridge includes the following elements:

1. The internal structure of the primary pilaster shall be standard Basalite concrete masonry units*. Contact Basalite at (707) 678-1901 for more information.
2. The stone veneer for the wall shall be a manufactured stone, El Dorado Stone Sanibel Coastal Reef.* Stone shall be a drystack pattern with minimal to no joints between stones. Stone shall be located on all sides of the monument. Stone end pieces shall be used at all wall 90 degree corners. The protrusion of the stone veneer shall not extend beyond the bottom width of the concrete pilaster cap. All stone veneer shall receive two coats of El Dorado Stone Craftshield Manufactured Stone Veneer Protective Product*. Contact El Dorado Stone at (800) 925-1491 for more information.
3. The stone veneer and wainscot sill mortar shall be Orco Blended Products Poly VBM 300, Veneer Bonding Mortar - Poly Modified Mortar* and shall be selected for use on vertical surfaces. Color: Surf*. Contact Orco Blended Products at (951) 818-4054 for more information.
4. The primary pilaster cap shall be a Handalstone custom precast concrete cap*. Profile to match PC5. Bottom width 4'-1" x 3'-1", overall width 4'-5" x 3'-5", height 9". Color: Harvest (73). Texture: Stone Travertine (4). The pilaster cap shall be constructed in four equal pieces and mortared together on site to create one continuous cap. The bottom width of pilaster cap shall extend 1/2" minimum beyond the stone veneer on all sides. Contact Handalstone at (916) 386-1430 for more information.
5. The accent pilaster cap shall be a Handalstone custom precast concrete cap*. Profile to match PC5. Bottom width 28", overall width 31", height 6-1/2". The bottom width of pilaster cap shall extend 1/2" minimum beyond the stone veneer on all sides. Color: Harvest (73). Texture: Stone Travertine (4). Contact Handalstone at (916) 386-1430 for more information.
6. The wainscot sill shall be a Handalstone custom precast concrete wainscot sill*. The wainscot sill shall be 6" deep and protrude out 6" from the wall. Color: Harvest (73). Texture: Stone Travertine (4). Contact Handalstone at (916) 386-1430 for more information.
7. The primary pilaster cap and accent pilaster cap shall be attached with Orco Blended Products R-Lastic waterproof elastomeric coating and VBM Bonder polymer modified thin set*. Color: Pearl*. Contact Orco Blended Products at (951) 818-4054 for more information.
8. The primary pilaster cap and wainscot sill joints shall be finished with Orco Blended Products VP Joint Grout premium sand grout with polymer. Color: Pearl. Contact Orco Blended Products at (951) 818-4054 for more information.
9. The 2" square railings are constructed out of square tubular steel as required by the City, with a black painted finish, welded together to create a consistent bridge railing.

* = Or approved equivalent

CHAPTER 2

STREETS & STREET LANDSCAPING: VEHICULAR BRIDGE

10. The metal wrap-around panel attached to the wall shall be a 1" thick panel, with a 3-1/2" high x 1-1/2" wide lip all sides which abuts the stone veneer. The metal wrap-around panel shall be attached to the block wall of the primary pilaster. The metal panel shall be one continuous piece of metal to prevent gaps. The metal panel shall be powder coated with the color Copper (Stellix 49/90620)* and finished with a clear top coat as available from Tiger Drylac USA*, contact (800) 243-8148 for more information. This color shall be used on all bridge primary pilaster.
11. The logo attached to the metal wrap-panel shall be designed and/or selected by the City. The logo shall be laser cut aluminum with an acrylic paint finish, and attached to the CMU block wall of the pilaster through the metal wrap-around panel. The logo shall be located on the front and channel side of the pilaster. The logo shall be approximately 12" in height and shall be approximately 2" thick. The logo shall be surfaced mounted and held a minimum of 1/2" off of the face of the metal panel to provide visual relief and shadow. The logo's color shall match the sign lettering color on all Primary and Secondary Entry Monuments (refer to Chapter 3). The specific size of the logo shall be selected by the City and used on all vehicular bridges.
12. The Landscape Median across each vehicular bridge shall only include shrubs and groundcover. No trees shall be located within any Landscape Median on a vehicular bridge.

* = Or approved equivalent

Design Elements

Refer to General Standards & Reference Items section this chapter for more information

- | | | | | |
|----------------------------|---|--|---|---|
| 1. Medium Shrub | a. Major Drainage Channel (refer to Chapter 5) | e. Poured-In-Place Concrete Wall | j. Split Rail Fence | o. CMU Block at Primary Monument |
| 2. Small Shrub (not shown) | b. Major Drainage Channel Landscape Corridor (refer to Chapter 5) | f. Stone Veneer | k. Primary Streetlight | p. Mortar Bed |
| 3. Groundcover | c. Primary Pilaster | g. Wainscot Sill | l. Precast Culvert (as required) | q. Metal Logo Attached to Wrap-Around Panel |
| | d. Accent Pilaster | h. 2" Square Railing | m. Metal Wrap-Around Panel (refer to Metal Wrap-Around Panel Attachment detail) | r. Logo Enlargement A |
| | | i. Colored Stamped Concrete Maintenance Safety Strip at Landscape Median/Turn Pocket | n. Pilaster Cap | s. Logo Enlargement B |
| | | | | t. Logo |

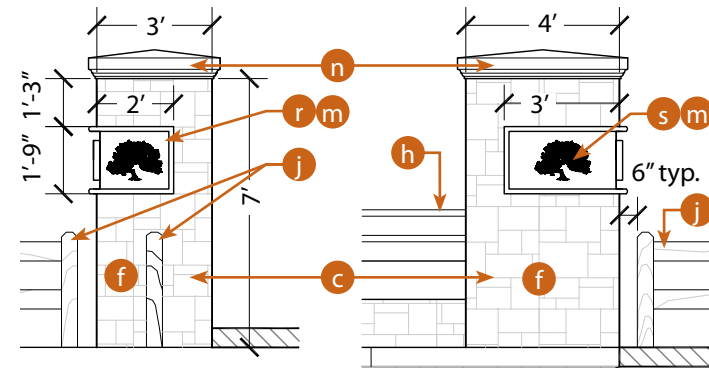

Elevation A - Not to Scale

Elevation B - Not to Scale

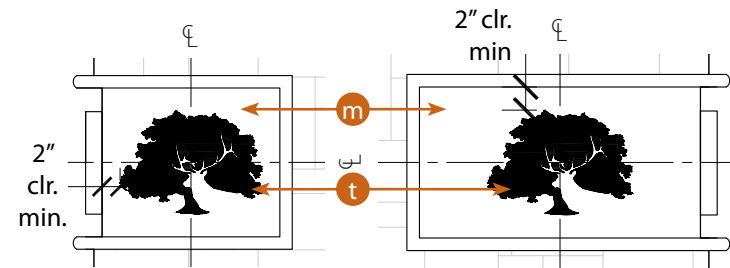

Logo Enlargement A

Logo Enlargement B

Not to Scale

Not to Scale

Metal Wrap-Around Panel Attachment

Not to Scale

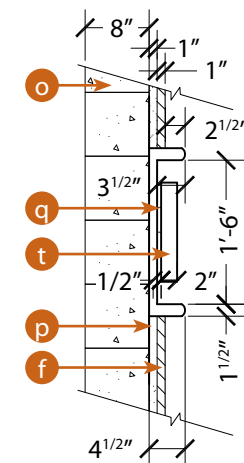

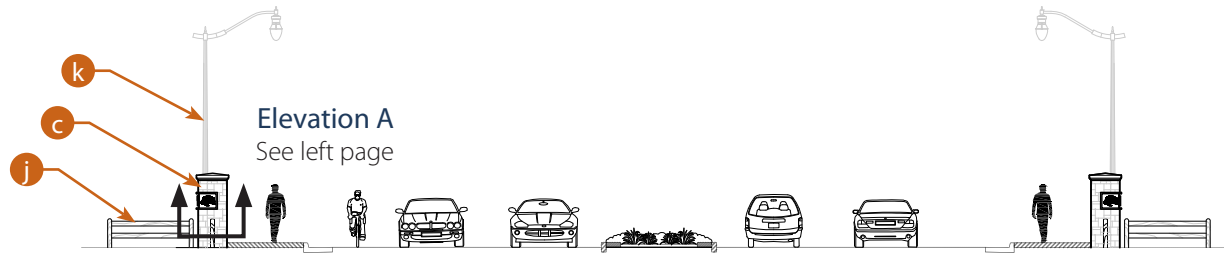

Section 'A' - Not to Scale

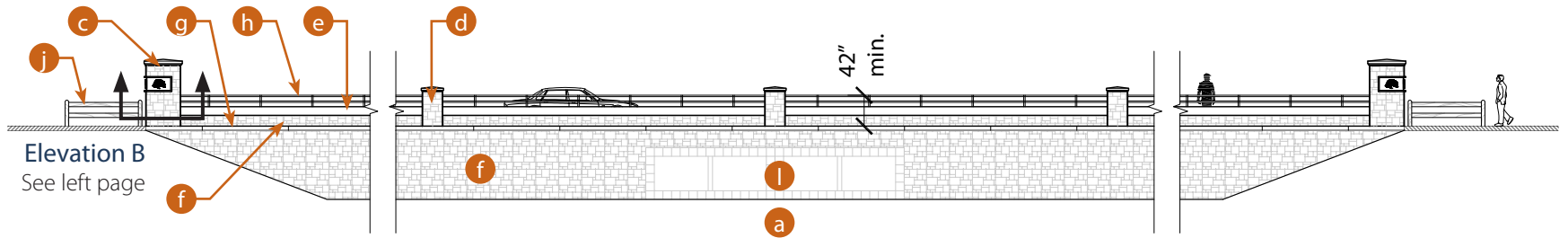

Section 'B' - Not to Scale



Example 1 & 2: Vehicular Bridge

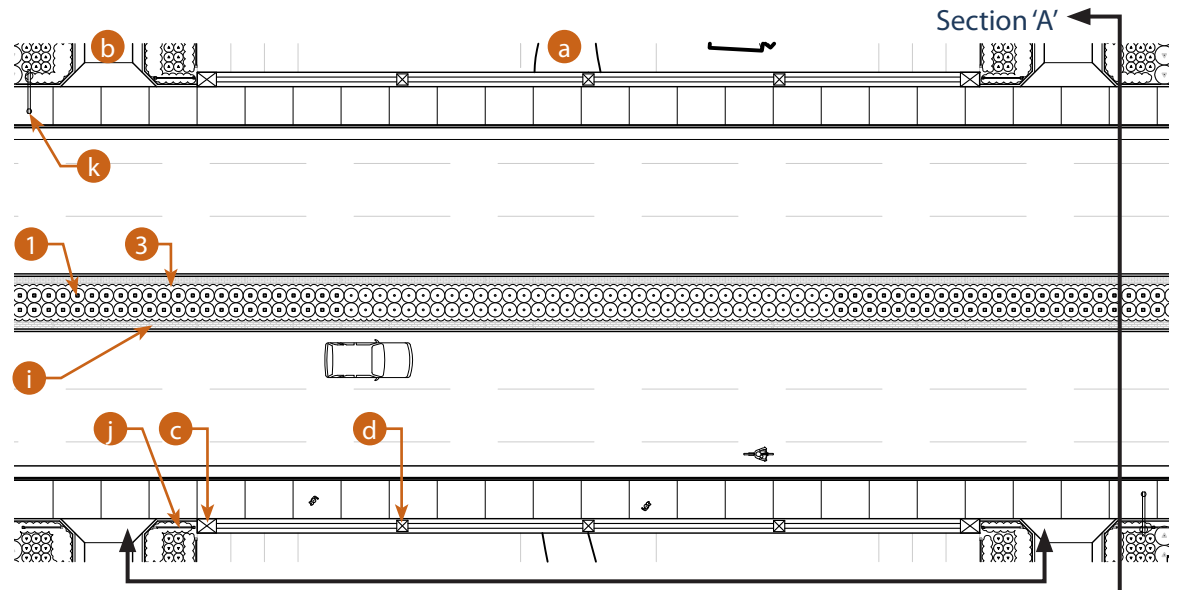

Plan - Not to Scale

CHAPTER 3

ENTRY MONUMENTS, WALLS & FENCES

SOUTHEAST POLICY AREA

SPECIAL PLANNING AREA

LANDSCAPE PLANNING PROTOTYPE MANUAL

CHAPTER 3

ENTRY MONUMENTS, WALLS & FENCES

A. CHAPTER OVERVIEW

Entry monuments, community walls, pilasters and fences provide a sense of arrival and establish a distinctive identity for the Plan Area. The overall community design is created and reinforced through repetition of common elements, thematic materials, sizes, textures and colors. Materials include a mix of stone, concrete (cast in place and precast), metal, and wood that are blended together to create a seamless transition between land uses. The design of the entry monuments, community walls, pilaster and fences, and their hierarchy of scales when combined together, invoke a contemporary feeling throughout the Plan Area.

B. GENERAL STANDARDS & REFERENCE ITEMS**1. Materials Standards**

The following is a list of material requirements for all entry monuments, entry monument lettering and logos, walls and fences. Exceptions to the list are as noted:

1. The internal structure of the Entry Monuments, Community Pilasters, and Low Pilasters shall be standard Basalite concrete masonry units ("CMU")*. Contact Basalite at (707) 678-1901 for more information.
2. The Community Wall block shall be Basalite 6" x 8" x 16" Split face CMUs, both sides*. Color shall be #101 (Standard Color). These split face Community Walls shall be constructed using the "Proto II" wall system. Contact Basalite at (707) 678-1901 for more information.
3. Courtyard Wall, Stone Veneer Courtyard Wall, Seatwall and Stone Veneer Seatwall wall block shall be standard Basalite 6" x 8" x 16" CMUs*. Contact Basalite at (707) 678-1901 for more information.
4. Open View Fence with Low Wall block shall be Basalite 8" x 8" x 16" Split face CMUs, both sides*, to accommodate fence posts. Color shall be #101 (Standard Color). Contact Basalite at (707) 678-1901 for more information.
5. The stone veneer shall be a manufactured stone, El Dorado Stone Sanibel Coastal Reef*. Stone shall be a drystack pattern with minimal to no joints between stones. Stone shall be located on all sides of each entry monument. Stone end pieces shall be used at all wall 90 degree corners. The protrusion of the stone veneer shall be flush with the bottom width of the pilaster cap or wall cap. All stone veneer shall receive two coats of El Dorado Stone Craftshield Manufactured Stone Veneer Protective Product*. Contact El Dorado Stone at (800) 925-1491 for more information.
6. The Entry Monuments, Community Pilaster, and Low Pilaster pilaster cap shall be a Handalstone custom precast concrete cap*. Profile to match PC5. Color: Harvest (73). Texture: Stone Travertine (4). Contact Handalstone at (916) 386-1430 for more information. Specific cap information is as follows:
 - Primary Entry Monument: Bottom width 6'-1" x 5'-1", overall width 6'-5" x 5'-5", height 9". The pilaster cap shall be constructed in four equal pieces and mortared together on site to create one continuous cap.
 - Secondary Entry Monument, Neighborhood Entry Monuments #1 & #2, and Employment Area Entry Monuments: Bottom width 5'-1" x 4'-1", overall width 5'-5" x 4'-5", height 9". The pilaster cap shall be constructed in four equal pieces and mortared together on site to create one continuous cap.
 - Neighborhood Entry Monuments #3 & #4: Bottom width 4'-1" x 3'-1", overall width 4'-5" x 3'-5", height 9". The pilaster cap shall be constructed in four equal pieces and mortared together on site to create one continuous cap.
 - Community and Low Pilasters: Standard bottom width 28", overall width 31", height 6-1/2".
7. The Primary Entry Monument, Secondary Entry Monument, Neighborhood Entry Monuments #1, #2 and #3, Community Wall, Courtyard Wall, Stone Veneer Courtyard Wall, Seatwall, and Stone Veneer Seatwall wall cap shall be a custom precast concrete wall cap. Profile to match Handalstone PC5*, unless otherwise noted. Color:

*=Or approved equivalent

Harvest (73). Texture: Stone Travertine (4)*. Each wall cap is 24" long. A wall end cap piece shall be used at the terminus of the wall (if it does not terminate at a pilaster). Contact Handalstone at (916) 386-1430 for more information. Specific wall cap information is as follows:

- Primary and Secondary Entry Monument: Bottom width 21", overall width 24", height 6-1/2".
 - Neighborhood Entry Monuments #1 & #2: Bottom width 13", overall width 15", height 4".
 - Neighborhood Entry Monument #3: Bottom width 12", overall width 14", height 2-3/4". Wall cap shall be flat without any peak to provide a flat surface for the metal grid panel.
 - Community Wall and Open View Fence with Low Wall: Bottom width 9", overall width 12", height 6-1/2". All concrete wall caps to be used on Community Walls shall have a void in the bottom of the cap to accommodate for the "Proto II" wall system's tensioning hardware.
 - Courtyard Wall: Bottom width 10", overall width 12", height 4".
 - Stone Veneer Courtyard Wall: Bottom width 11", overall width 13", height 4".
 - Seatwall: Bottom width 10", overall width 12", height 2-3/4". All Seatwall caps shall be flat without any peak to allow pedestrians to sit on cap.
 - Stone Veneer Seatwall: Bottom width 11", overall width 13", height 2-3/4". All seatwall caps shall be flat without any peak to allow pedestrians to sit on cap.
8. Open View Fence with Low Wall wall cap shall be a standard precast concrete wall cap. Profile to match Handalstone WC515*. Color: Harvest (73). Texture: Stone Travertine (4)*. Each wall cap is 24" long. Contact Handalstone at (916) 386-1430 for more information.
9. The Community Wall and Open View Fence with Low Wall CMU block mortar shall be Basalite Amerimix "Type S" mortar. Color: 381*. Contact Basalite at (707) 678-1901 for more information.
10. The stone veneer mortar shall be Orco Blended Products Poly VBM 300, Veneer Bonding Mortar* - Poly Modified Mortar and shall be selected for use on vertical surfaces. Color: Surf. Contact Orco Blended Products at (951) 818-4054 for more information.
11. Pilaster and wall caps shall be attached with Orco Blended Products R-Lastic waterproof elastomeric coating* and VBM Bonder polymer modified thin set*. Color: Pearl*. Finish with Orco Blended Products VP Joint Grout premium sand grout with polymer. Color: Pearl. Contact Orco Blended Products at (951) 818-4054 for more information.
12. The Courtyard Wall and Seatwall stucco shall have a "Fine" Stucco finish, 1" thick Omegaflex 3-coat stucco system*. Process shall include base coat, primer coat, and finish coat per manufacturer's specifications and details. All CMU joints and any imperfections shall not be visible through finish coat. Stucco shall be flush with bottom width of wall cap. Prime and paint with two (2) coats of exterior latex paint, color to match or compliment adjoining/adjacent building color. Contact Silverado Building Materials (916) 361-7374 for more information.
13. The Primary Entry Monument, Secondary Entry Monument, and Neighborhood Entry Monuments #1, #2 & #4 metal wrap-around panels shall be a 1" thick panel, with a 3-1/2" high by 2" wide lip all sides which abuts the stone veneer. The metal wrap-around panel shall be attached directly to the block wall and shall wrap around the block wall and terminate on the back side of the wall. The metal wrap-around panel shall be one continuous piece of metal to prevent gaps as it wraps around the wall. Specific conditions apply to the Neighborhood Entry monuments:

* = Or approved equivalent

CHAPTER 3

ENTRY MONUMENTS, WALLS & FENCES: GENERAL STANDARDS & REFERENCE ITEMS

- Neighborhood Entry Monuments #1, #2 & #4: The lettering side of the metal panel shall be located on the front of the pilaster which faces the intersection into the community. The logo side of the metal pilaster shall be located on the side of the pilaster and face the street.
14. The Primary Entry Monument, Secondary Entry Monument and Neighborhood Entry Monument #3 metal medallions shall be a 1" thick panel, with a 3-1/2" high by 2" wide lip all sides which abuts the stone veneer. The metal medallion shall be attached directly to the block wall, and shall be one continuous piece of metal to prevent gaps. The logo side of the metal medallion shall face the intersection to the community. The metal medallion's materials, powder coat color, and top coat shall match those used on the metal wrap-around panel.
15. Neighborhood Entry Monuments #1, #2, #3 and Employment Area Entry Monuments shall include a metal grid panel. The metal grid panel is broken down into three major elements: (1) the 3" outer frame assembly, (2) the grid section and (3) the tubular steel mounting brackets attaching the panel to the pilaster. The outer frame assembly of the grid panel shall be 1/4" x 3" x 3" steel angle L channels, mitered all corners. The L channel outer frame assembly creates the exterior framing for the grid section. The metal grid section shall be constructed using 1" wide x 4" high x 1" deep grids with 1" wire U edging on all side mitered at corners. Refer to the images on the opposing page for more information regarding the design of the metal grid panel. Specific metal grid panel information as follows:
- Neighborhood Entry Monuments #1, #2 & #3: The metal grid sections and L channel outer frame assembly shall be attached together using hex bolts, or similar attachment. Because these Neighborhood Entry Monuments can be seen when entering and existing the neighborhood, an identical metal grid section with L channel outer frame assembly shall be mirrored facing the other direction. Both structures shall be welded together to create one solid metal grid panel that is 6" in width at the outer frame assembly. The outer frame assembly shall sit 1" off the top of wall cap.



**Example of L Channel
Outer Frame at corner**



**Example of Metal Grid Panel
Mounting Bracket, when
applicable** (Metal Frame to Pilaster)



**Example of Hex Bolt
Attachment/Accent**
(Metal Grid Panel to Frame)



**Example of Metal Grid
Section**



**Example of L Channel Outer
Frame and Metal Grid Interface**



**Example of Metal
Grid Panel** (Overall)

The solid metal structure is attached to the Neighborhood Entry Monument pilasters in slightly different ways:

- Neighborhood Entry Monuments #1 & #2: Multiple 1" x 3" tubular steel mounting brackets attached to pilaster's block wall internal structure with steel mounting plates and concrete anchor bolts, or as required by the structural engineer.
 - Neighborhood Entry Monument #3: Attachment as required by the structural engineer.
- Employment Area Entry Monument: Four grid sections are required for this monument (each visible side). The metal grid sections and L channel outer frame assembly shall be welded together in the interior of the metal structure, or similar attachment. This structure is entirely welded together, not bolted. However, hex bolts may be located on the grid panel as accents. Additionally, a 3" deep arched metal cap shall be welded to the top of the metal grid panel. Finally, a solid sheet metal accent panel shall be located at the bottom of the metal grid panel. Once together, the metal grid panel shall be attached to the pilaster as required by the structural engineer. Because the Employment Area Entry Monument is a stand-alone monument that will be seen from all four sides, the interior of the metal grid panel shall be internally illuminated and/or internally up-lighted. Due to the interior lighting within the metal grid panel, access should be provided within the metal structure for maintenance of all lighting.
16. When an Entry Monument's metal panel, wrap-around panel, medallion, and/or grid panel are featured on an entry monument, it/they shall be powder coated with the color Copper (Stellix 49/90620)*, unless otherwise noted, and finished with a clear top coat as available from Tiger Drylac USA*, contact (800) 243-8148 for more information.
 17. The Employment Area Entry Monument metal grid panel, arched metal cap, and metal accent panel shall be powder coated with either the color Copper (Stellix 49/90620)* or Standard Silver (Stellix 49/90380)*.
 18. All wood fencing throughout the Plan Area shall be Cedar and shall receive a minimum two coats of semi transparent stain, Mushroom #910 by Olympic Stain*.
 19. Open View Fence and Open View Fence with Low Wall shall be constructed out of square tubular steel, welded together to create a consistent view fence. Fence shall receive two coats of painted black finish. Fence shall be 6' tall (may be shorter with approval from the City).
 20. Tubular Steel Fence with Accents shall be constructed out of square tubular steel and accented with circular steel, welded together to create a consistent decorative fence. Fence shall receive two coats of painted black finish. Fence shall be 42" high (may be shorter with approval from the City).
 21. All Split Rail Fences shall be Artisan Precast Woodcrete* two rail precast split rail concrete fence. Color: Sandstone (Standard Color)*. The design shall be reminiscent of a traditional farm fence. Fence post style shall vary based on the following conditions: (1) line post for standard runs of fencing, (2) end posts at the terminus of fencing, and (3) corner posts at corners and significant changes of direction of fencing. Split Rail Fence shall be 3' tall. Posts shall be located 8' on center and at any changes of direction. Contact Artisan Precast at (800) 511-2747 for more information.
 22. Post and cable fence shall be constructed and installed per City of Elk Grove Standard Detail L-20, latest version.

* = Or approved equivalent

2. General Landscaping Standards

The following is a list of general landscaping requirements for all entry monuments, walls & fences. Exceptions to the list are as noted:

1. Enriched landscaping is required at all entry monument locations. One-hundred percent (100%) of all shrubs shall be 5-gallon in size. Plants that are not commercially available in a 5-gallon size, may be substituted for a 1-gallon size. (Refer to Chapter 6)
2. All groundcover at Primary, Secondary, and Neighborhood Entry Monuments #1 & #2 shall be 1-gallon minimum. Groundcover shall be located a maximum of 3' on center spacing. (Refer to Chapter 6)
3. Street Trees as required along specific street. Refer to Chapter 2 to reference specific street. Refer to General Landscape Plant Palette and Major Streetscape Street Tree List, Chapter 6.
4. Primary and Secondary Entry Monument Specimen Trees - six total per corner, three (3) each side of monument (48" box). Refer to Primary and Secondary Monument Plan - Enlargements and Chapter 6 for more information.
5. Primary Entry Monument Major Accent Trees - three (3) behind primary monument (48" box). Refer to Primary Monument Plan - Enlargement and Chapter 6 for more information.
6. Neighborhood Entry Monument #1 & #2 Specimen Trees - two total per monument, one (1) each side of metal grid panel (36" box). Refer to Neighborhood Entry Monument #1 & #2 Plan - Enlargements and Chapter 6 for more information.
7. When any of the following elements are featured on Primary, Secondary, and Neighborhood Entry Monuments, it/they shall be up-lighted with vandal-proof, ground-mounted lighting fixtures and shall not be box or back lighted, unless otherwise noted:
 - Lettering
 - Logo
 - Medallion
8. Employment Area Entry Monuments shall be lighted per City requirements.
9. Landscape lighting is not required throughout the Plan Area. If landscape lighting is proposed in publicly maintained areas, it shall be a vandal-proof fixture as approved by the City.

3. Lettering & Logo Standards

a. Lettering & Logo Materials Standards

The following is a list of lettering and logo material requirements for all Entry Monuments. Exceptions to the list are as noted:

1. All Entry Monument's lettering and logos shall be laser cut aluminum with an acrylic paint finish and shall be attached to the CMU block wall through the metal panel, metal wrap-around panel, and/or medallion, unless otherwise noted. The letter and logos shall be surfaced mounted, and held a minimum of 1/2" off of the face of the metal panel to provide visual relief and shadow. Lettering shall be individual lettering, not continuous, and shall be independent of metal panel, metal wrap-around panel, and medallion. Refer to Lettering and Logo Standards section of this chapter for more information.
2. The Entry Monument's lettering and, when applicable, logo shall receive one coat of Pro Industrial Pro-Cryl Universal Acrylic Primer* applied per the manufacturer's specifications. Following the coat of primer, 2 coats of Pro-Industrial DTM Acrylic Coating* shall be applied per the manufacturer's specifications, color shall be Navajo White (SW6126)*, unless otherwise noted. Available from Sherwin Williams, contact (800) 524-5979 for more information.
 - The Employment Area Entry Monument lettering's color shall vary based on the color of the metal grid panel: 1) If the metal grid panel's color is Copper, then the lettering's color shall be Navajo White (SW6126)*, or 2) If the metal grid panel's color is Standard Silver, then the lettering's color shall be Black of Night (SW6993)*.
3. Employment Area Entry Monument's tenant sign lettering panel shall be attached to an internally illuminated box that wraps around two sides of the pilaster. Each tenant sign on the street side of the monument ("primary panel") shall be composed of two layers ("facade" and "sub-layer"). The tenant sign lettering facade layer shall be a computer cut, acrylic-painted aluminum panel with an acrylic panel sub-layer behind to provide contrast and relief, as well as back lighting. See the images below for examples of internally illuminated lettering. The primary panel facade layer's font/lettering shall match the letter branding/font requirements of each tenant. The primary panel facade layer's color shall match the metal grid panel. A colorful acrylic sub-layer shall contrast the facade lettering panel. The lettering on the driveway side of the monument ("secondary panel") shall be a solid, acrylic-painted aluminum panel without any lettering. The secondary panel's color shall be identical to the color of the primary panel facade layer. Both the primary and secondary panels shall be constructed and installed so that they can be easily removed, maintained, and replaced when necessary. The City shall approve the exact materials used to create all panels and the internally illuminated box.



Example of Internally Illuminated Lettering (Facade and Sub-Layer)

(typ. of 2)

*=Or approved equivalent

The following text and images describe and illustrate the lettering and logo requirements for all Entry Monuments.

4. The metal lettering and logo content for all Entry Monuments shall be approved by the City prior to installation.
5. Developers shall provide one complete spare set of letters to the City Operations & Maintenance Division for each monument constructed.
6. The lettering font shall be Helvetica 55 Roman for the first word and Helvetica 45 Light for the second word.
7. Lettering and logo requirements are listed below. Refer to the following pages for images of the lettering and logo requirements for the individual Entry Monuments:
 - Primary and Secondary Entry Monument:
 - a. Each letter shall be approximately 15" in height and shall be approximately 3" thick.
 - b. The logo shall be approximately 18" in height and shall be approximately 3" thick.
 - Primary Entry Monument: The Primary Entry Monument logo's content shall be used on all Primary Entry Monuments.
 - Secondary Entry Monument: The Secondary Entry Monument logo's content shall be used on all Secondary Entry Monuments.
 - Neighborhood Entry Monuments #1, #2 & #4:
 - a. The size of each letter shall be determined by the final verbiage provided by the Residential Unit Builder, but is required to be 6" at minimum. Each letter shall be approximately 2" thick.
 - b. The logo shall be approximately 12" in height and shall be approximately 2" thick.
 - Neighborhood Entry #3 Monument:
 - a. The size of each letter shall be determined by the final verbiage provided by the Residential Unit Builder, but is required to be 6" at minimum. Each letter shall be approximately 2" thick.
 - Employment Area Entry Monument:
 - a. The size of each vertical letter shall be determined by the final verbiage provided by the land owner/developer, but shall be approximately 9" in height and shall be approximately 1" thick. Lettering shall be located on two sides of the monument.
 - b. The logo shall be approximately 12-18" in height and shall be approximately 1" thick and located on two sides of the monument.

b. Primary & Secondary Entry Monuments

Refer to Lettering & Logo Material Standards on Page 3-8 and Lettering & Logo Standards on Page 3-9

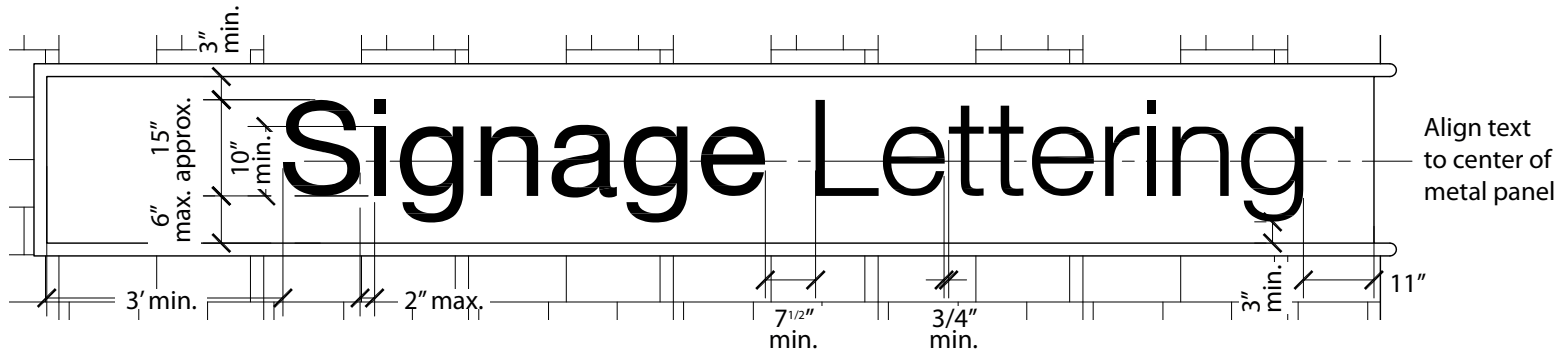

Primary Monument Lettering Requirements - Not to Scale

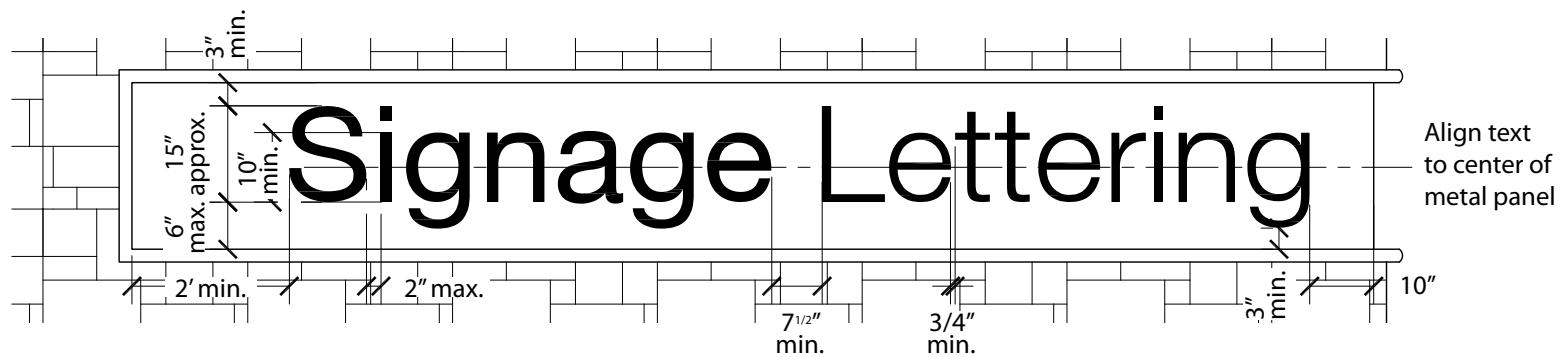

Secondary Monument Lettering Requirements - Not to Scale

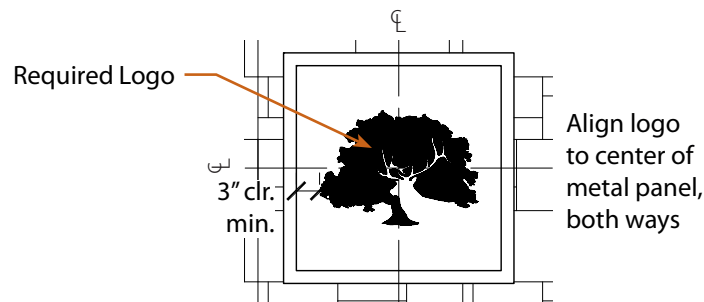

Primary & Secondary Monument Logo Requirements - Not to Scale

CHAPTER 3

ENTRY MONUMENTS, WALLS & FENCES: GENERAL STANDARDS & REFERENCE ITEMS

c. Neighborhood Entry Monuments

Refer to Lettering & Logo Material Standards on Page 3-8 and Lettering & Logo Standards on Page 3-9

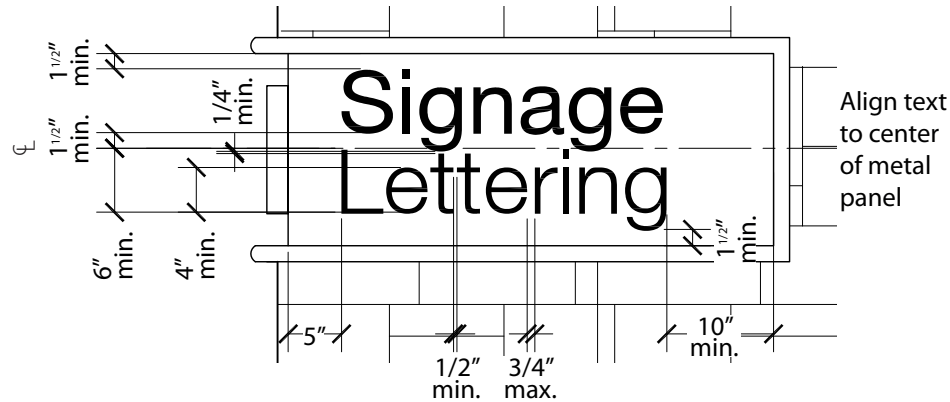

Neighborhood Entry Monument #1 & #2 Lettering Requirements -
Not to Scale

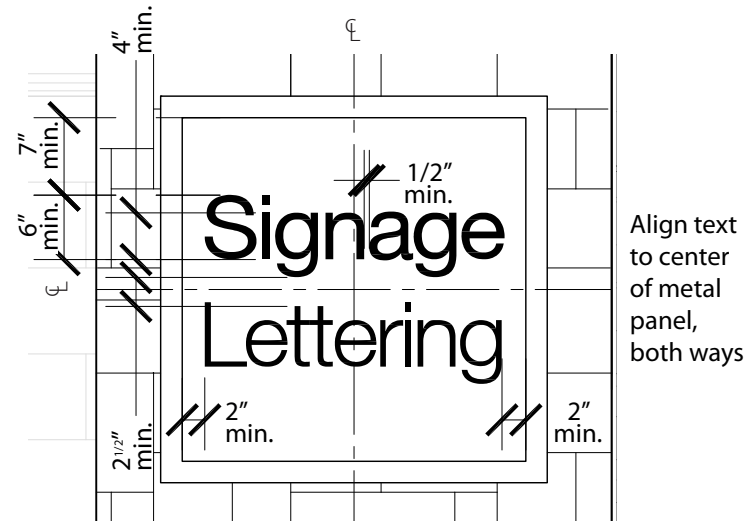

Neighborhood Entry Monument #3 Lettering Requirements - Not to Scale

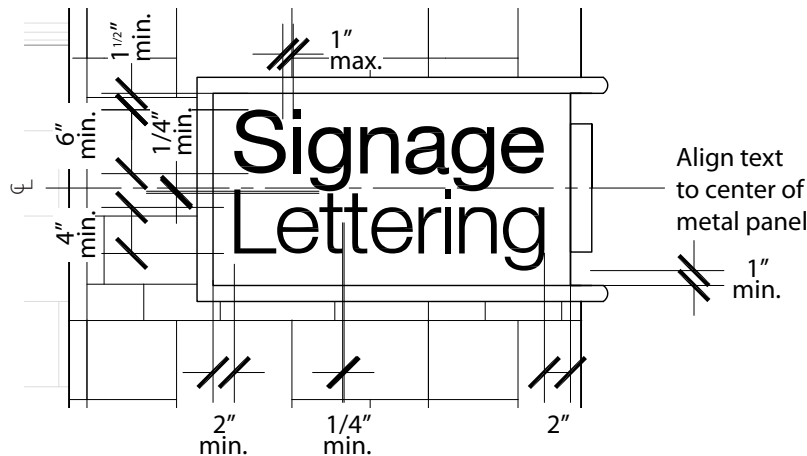

Neighborhood Entry Monument #4 Lettering Requirements -
Not to Scale

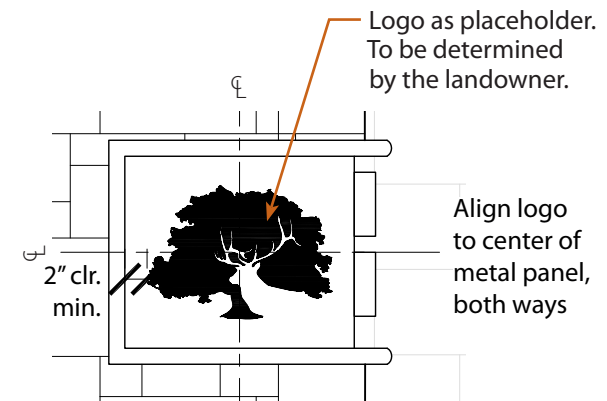

Neighborhood Entry Monument #1, #2 & #4 Logo Requirements - Not to Scale

d. Employment Area Entry Monuments

Refer to Lettering & Logo Material Standards on Page 3-9 and Lettering & Logo Standards on Page 3-10

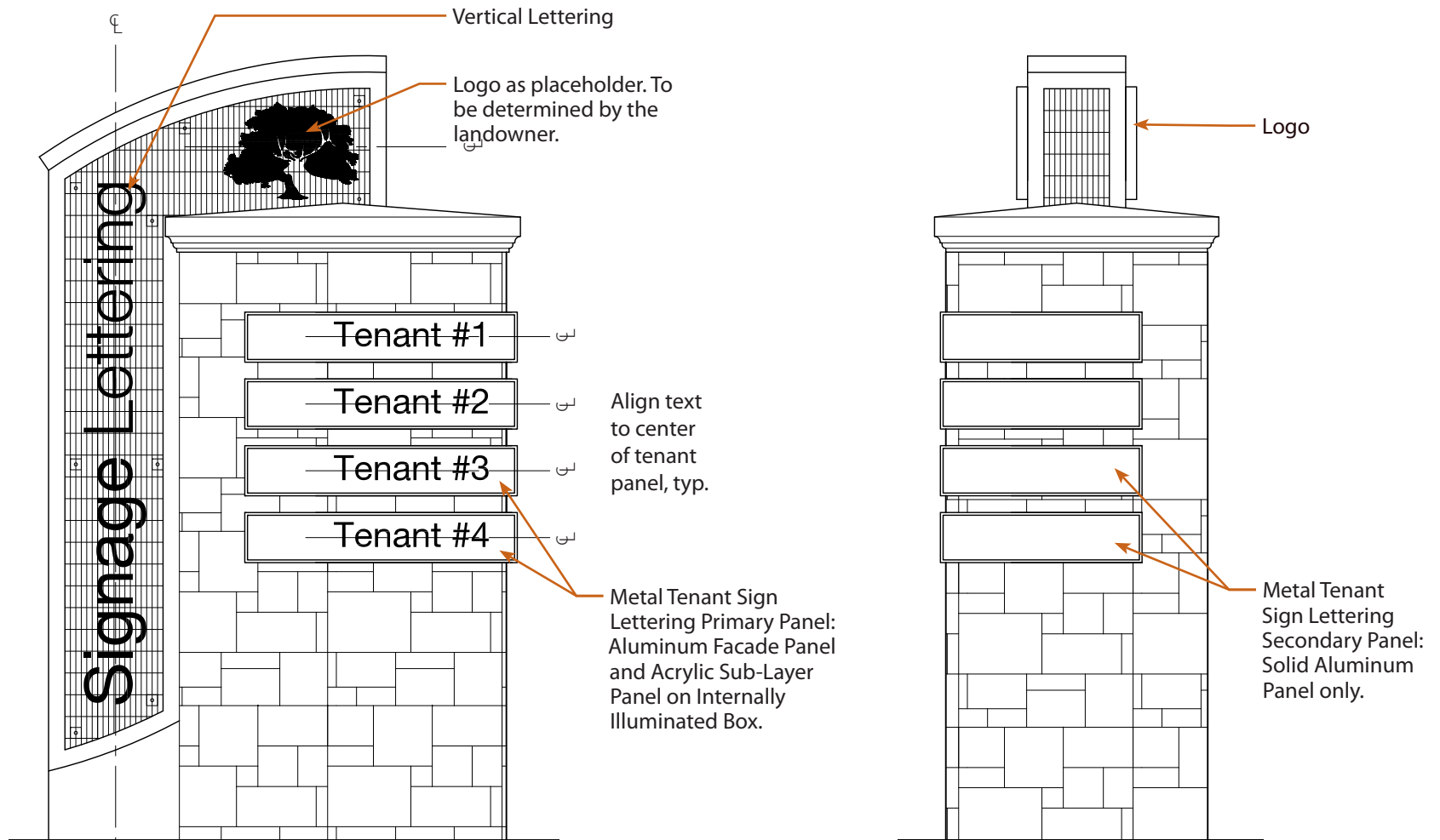

**Office and Light Industrial/Flex
Lettering and Logo Requirements
Elevation A (Street Side) - Not to Scale**

**Office and Light Industrial/Flex
Lettering and Logo Requirements
Elevation B (Driveway Side) - Not to Scale**

4. Reference Items**Planting and Landscape**

Refer to the following chapters of this Manual as required:

1. Primary Street Tree (refer to Chapter 6)
2. Major Accent Tree (refer to Chapter 6)
3. Accent Tree (refer to Chapter 6)
4. Specimen Tree (Refer to Chapter 6)
5. Large Shrub (refer to Chapter 6)
6. Medium Shrub (refer to Chapter 6)
7. Small Shrub (refer to Chapter 6)
8. Small Shrubs & Groundcover (refer to Chapter 6)
9. Vine (refer to Chapter 6)
10. Landscaping
(Private landscaping designed to the City's satisfaction and maintained by the landowner)

Hardscape and Amenities

Refer to the following chapters of this Manual: as required

1. Concrete Sidewalk. Score joints on-center spacing equal to width of sidewalk. Expansion joints spacing shall be as required per the Geotechnical Report. If no Geotechnical Report exists, expansion joints shall be every forth score joint minimum. (Refer to Geotechnical Report for the specific lot within the Plan Area for specific information on slab thickness, reinforcement, etc.)
2. Colored Concrete Enhanced Paving (refer to Chapter 2)
3. City of Elk Grove Type 3 Concrete Curb (refer to City of Elk Grove Standard Details)
4. Colored Stamped Concrete Maintenance Safety Strip at Landscape Median/Turn Pocket (refer Chapter 2)
5. Concrete Mowstrip (refer to City of Elk Grove Standard Details)
6. Redwood Headerboard (refer to Chapter 4)
7. Edging for Residential Lots. To be determined by the City.
8. Colored Stamped Asphalt Enhanced Paving Crosswalks (refer to Chapter 2)
9. Community Walls (refer to this Chapter)
10. Community Pilaster (refer to this Chapter)
11. Low Pilaster (refer to this Chapter)
12. Residential Wood Fence (refer to this Chapter)
13. Open View Fence (refer to this Chapter)
14. Open View Fence with Low Wall (refer to this Chapter)
15. Split Rail Fence (refer to this Chapter)
16. Post and Cable Fence (refer to this Chapter)
17. Tubular Steel Fence with Accents (refer to this Chapter)
18. Courtyard Wall (refer to this Chapter)
19. Stone Veneer Courtyard Wall (refer to this Chapter)
20. Seatwall (refer to this Chapter)
21. Stone Veneer Seatwall (refer to this Chapter)
22. Primary Entry Monument (refer to this Chapter)
23. Secondary Entry Monument (refer to this Chapter)
24. Neighborhood Entry Monuments (refer to this Chapter)
25. Employment Area Entry Monument (refer to this Chapter)
26. Primary Streetlight (refer to Chapter 4)
27. Tree Root Barrier (refer to Chapter 4)
28. City of Elk Grove Visibility Control Area (refer to City of Elk Grove Standard Details)
29. Land Uses (refer to the SPA, Chapter 2 Land Plan)

C. ENTRY MONUMENTS

1. Entry Monuments Overview

Entry monuments highlight and strengthen the overall community design theme within the Plan Area with consistent materials, distinctive signage and iconic logos. Entry monuments are located at specific intersections and key nodes within the Plan Area. Entry monuments include Primary, Secondary, Neighborhood, and Employment Monuments. The monumentation elements are developed at differing scales and demonstrate the relationship to their specific location and purpose. Refer to the Entry Monuments Plan in this chapter for Entry Monument locations.

The specific stone, concrete cap, metal panels, metal lettering & logos, as well as other metal accents, shall be consistent and repeated throughout all entry monuments within the Plan Area. The Employment Area Entry Monuments shall also use the specified stone, but the color of the metal and size/scale of the monument may vary as required by the land use and number of tenants. Any deviation from the Employment Area Entry Monument as described in the Manual shall be approved by the City. Entry monuments shall be located either within the Landscape Area of a Landscape Corridor, driveway entrance to the project site, or in the interior of a particular land use, as determined by this Manual and as required by the City. Entry monument locations shall comply with all City view triangle and sight distance requirements and shall not impede the view of pedestrians and vehicles at road crossings or other intersections.

In addition to the entry monumentation, lettering and logos located on the monuments are equally important to establish the identity of the Plan Area. The Primary and Secondary Entry Monument lettering and logos are distinct and convey a sense of place.

The Neighborhood and Employment Area Entry Monument lettering and logos are more schematic in nature, allowing the landowner or developer of that land use to market and brand their specific product type, while still maintaining overall theme and character. Employment Monument lettering and logos are also schematic, specific design will be determined through design review. Lettering and logo content shown herein is for illustrative purposes only and final content shall be determined through subsequent branding of the area.

Entry monumentation within all land uses shall follow the theme and design intent as specified in this Manual. Design implementation and materials may be substituted from those specified in this Manual, as long as the design consistency of all entry monumentation, including lettering and logos, is maintained. Any deviation to materials and design intent shall be approved by the City.

Please note, the locations specified in this chapter are the minimum entry monument requirements. Each landowner or developer may propose additional entry monument locations to be approved by the City.

Additionally, monument setback dimensions shown in this chapter are minimum values only and may vary. All monument sign locations and setbacks shall be submitted, evaluated and approved by the City and CCSD during the entitlement stage of each development project.

CHAPTER 3

ENTRY MONUMENTS, WALLS & FENCES: ENTRY MONUMENTS

2. Application List

Entry monumentation, including lettering and logos, shall exist at the following street locations and land uses within the Plan Area (or as determined by the City):

Primary Monuments

1. At Kammerer Road and Bruceville Road
2. At Kammerer Road and Big Horn Boulevard
3. At Kammerer Road and Lotz Parkway
4. At Bilby Road and Bruceville Road
5. At Poppy Ridge Road and Big Horn Boulevard
6. At Whitelock Parkway and Lotz Parkway

Secondary Monuments

1. At Kammerer Road and Collector Commercial #1
2. At Poppy Ridge Road and Lotz Parkway (two locations)
3. At Poppy Ridge Road and Residential Collector #2
4. At Poppy Ridge Road and Residential Collector #3
5. At Big Horn Boulevard and Collector Residential #1
6. At Lotz Parkway and Collector Residential #1
7. At Bilby Road and Big Horn Boulevard (two locations)
8. At Bilby Road and Lotz Parkway
9. At Bilby Road and Commercial Main Street (both intersections - two locations)
10. Promenade Parkway

Neighborhood Entry Monuments (Optional)

Gateway Feature

1. Location as directed by the City

Employment Area Entry Monuments (Optional)

3. Entry Monument Plan

The Entry Monument Plan shows the location and type of Entry Monuments found within the Plan Area. Additional monuments may be added as determined by the City.



CHAPTER 3

ENTRY MONUMENTS, WALLS & FENCES: ENTRY MONUMENTS

4. Primary Entry Monument

Primary Entry Monuments are the largest monuments of all the entry monuments, and convey to the user that they have entered the Plan Area. These monuments occur at specific high-traffic street intersections and whenever possible, shall be located on both sides of an intersection. The Primary Entry Monument is a combination pilaster and monument wall with a major signage feature. This monument has a CMU block internal structure creating the pilaster and wall, and veneered with a manufactured stone on all sides of the monument. Both the pilaster and wall are capped by a custom precast concrete cap, sized specifically to each wall or pilaster element. The Primary Entry Monument includes a metal wrap-around panel with lettering and metal medallion with logo. All elements of the Primary Entry Monument shall be consistent throughout the entire Plan Area, including the exact same stone, concrete caps and metal accents, as well as identical signage lettering, verbiage and logo. Refer to General Standards and Reference Items section in this chapter for more information.

Design Elements

Refer to General Standards & Reference Items section this chapter for more information

- A. Primary Entry Monument (refer to Elevation B)
- B. Arterial Street (refer to Chapter 2)
- C. Concrete Sidewalk
- D. City of Elk Grove Type 3 Concrete Curb
- E. Landscaping, typ. (refer to Primary Entry Monument Plan - Enlargement)
- F. Office Land Use (refer to Special Planning Area Document, Chapter 2)
- G. Commercial Land Use (refer to Special Planning Area Document, Chapter 2)

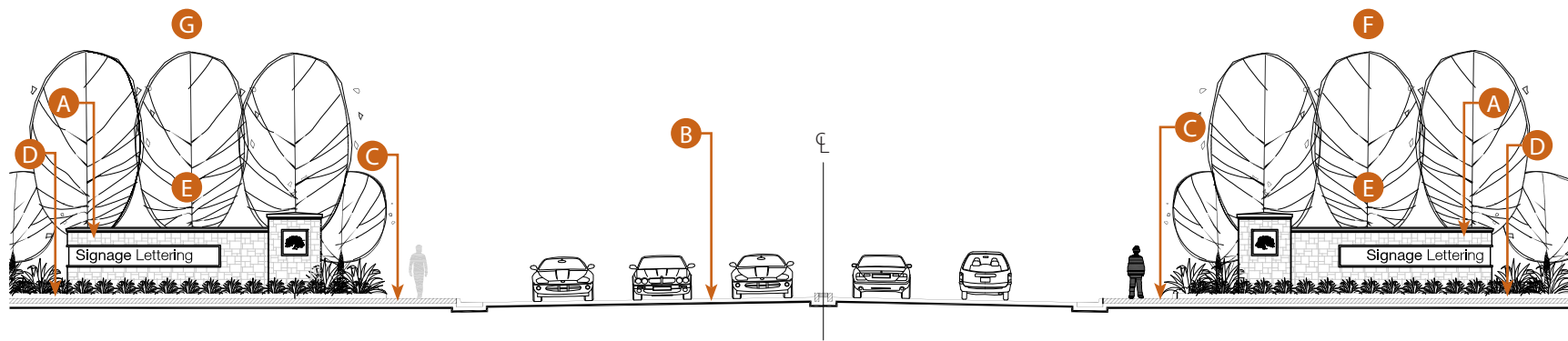

Primary Entry Monument - Elevation A

Not to Scale

Design Elements

Refer to General Standards & Reference Items section this chapter for more information

- 1. Pilaster
- 2. Pilaster Cap
- 3. Metal Medallion
- 4. Wall
- 5. Wall Cap
- 6. Stone Veneer
- 7. Metal Wrap-Around Panel (refer to Metal Wrap-Around Panel Attachment detail)
- 8. Landscaping, typ. (not shown - refer to Primary Entry Monument - Plan Enlargement)
- 9. Concrete Masonry Unit Block (CMU) at Monument
- 10. Stone Veneer Mortar Bed
- 11. Lettering Attached to Metal Wrap-Around Panel
- 12. Metal Wrap-Around Panel Attached to CMU Block
- 13. Lettering (TBD)
- 14. Logo (TBD)

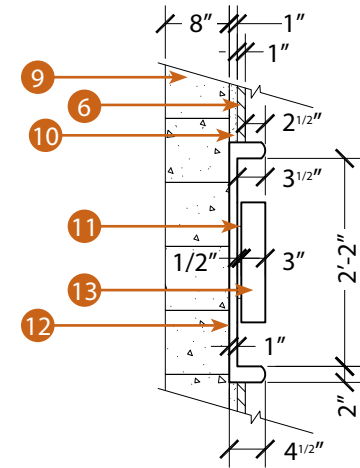

Metal Wrap-Around Panel Attachment

Not to Scale

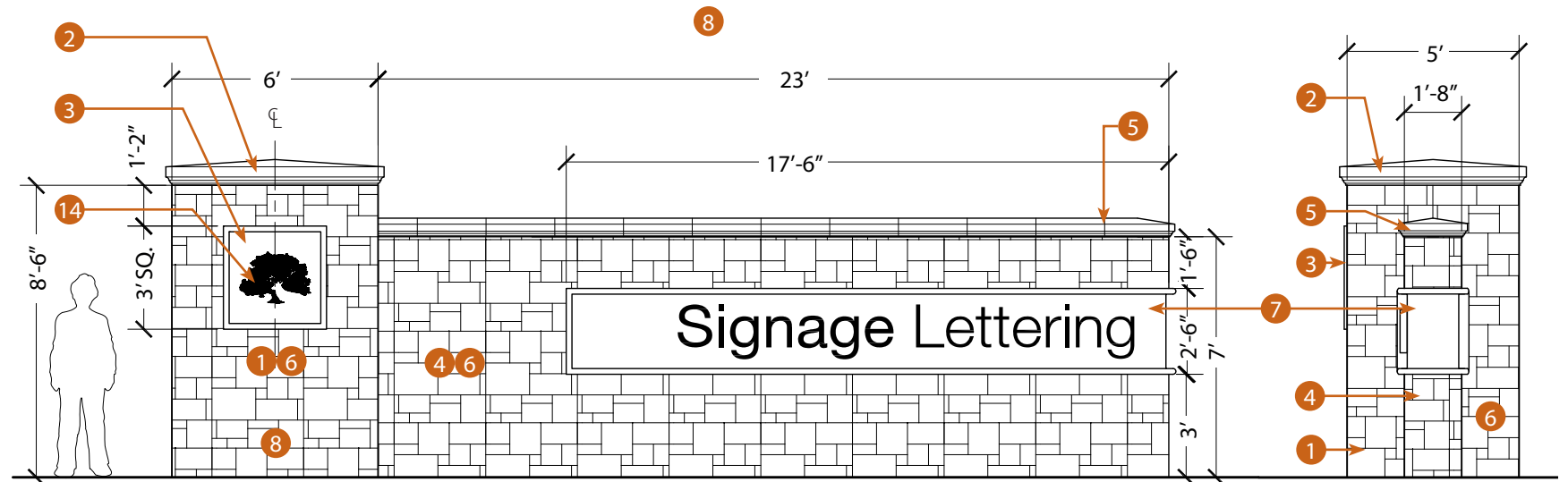

Primary Entry Monument - Elevation B

Not to Scale

Primary Entry Monument - Section

Not to Scale

CHAPTER 3

ENTRY MONUMENTS, WALLS & FENCES: ENTRY MONUMENTS

Design Elements

Refer to General Standards & Reference Items section this chapter for more information

- A. Primary Entry Monument
- B. Kammerer Road
- C. Arterial Street (refer to Chapter 2)
- D. Concrete Sidewalk
- E. Colored Concrete Enhanced Paving
- F. Colored Stamped Asphalt Enhanced Paving Crosswalk
- G. City of Elk Grove Type 3 Concrete Curb
- H. City of Elk Grove Visibility Control Area
- I. Colored Stamped Concrete Maintenance Safety Strip at Landscape Median/Turn Pocket
- J. Landscaping, typ. (refer to Primary Entry Monument - Plan Enlargement)
- K. Office Land Use (refer to Special Planning Area Document, Chapter 2)
- L. Commercial Land Use (refer to Special Planning Area Document, Chapter 2)
- M. Tree Root Barrier

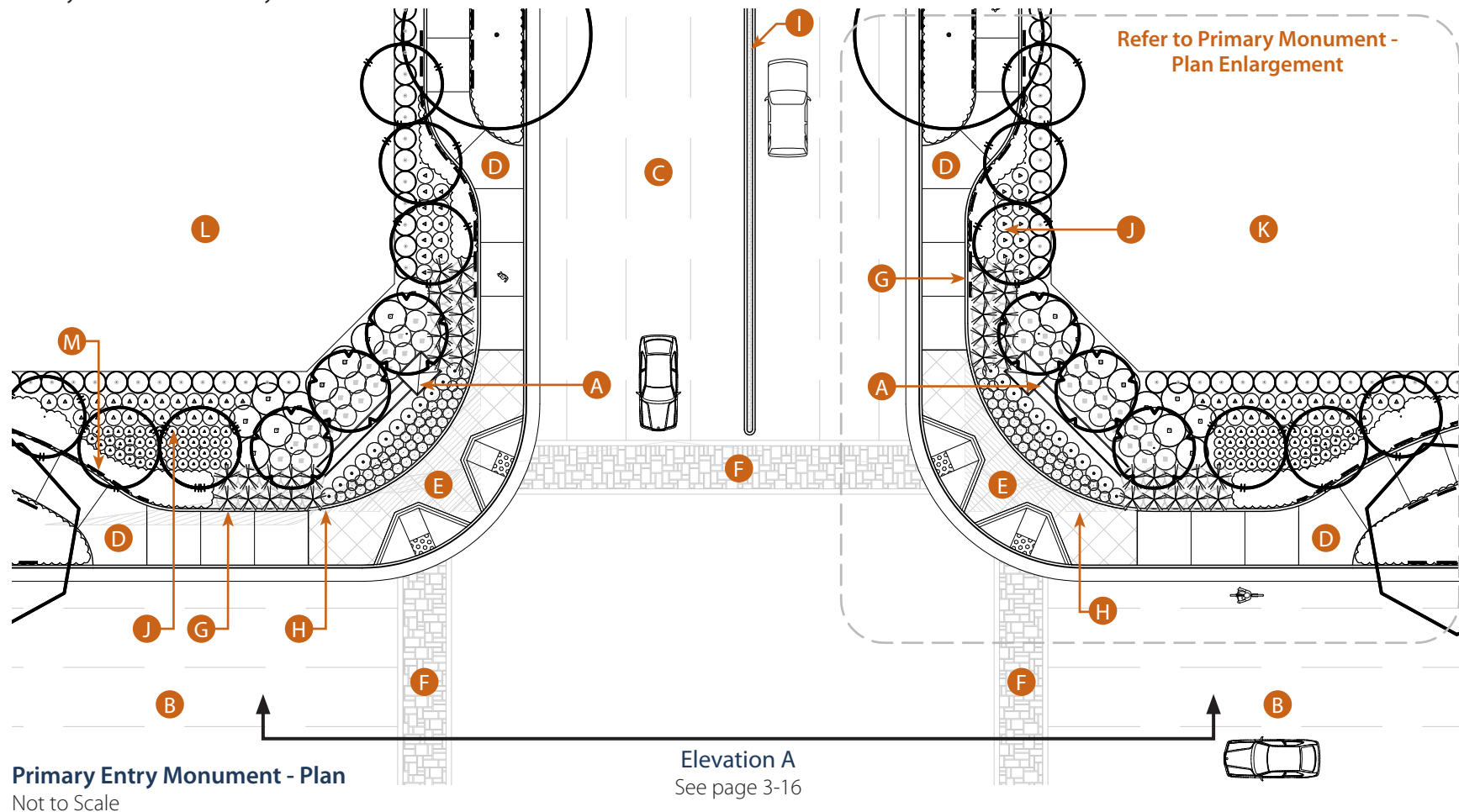

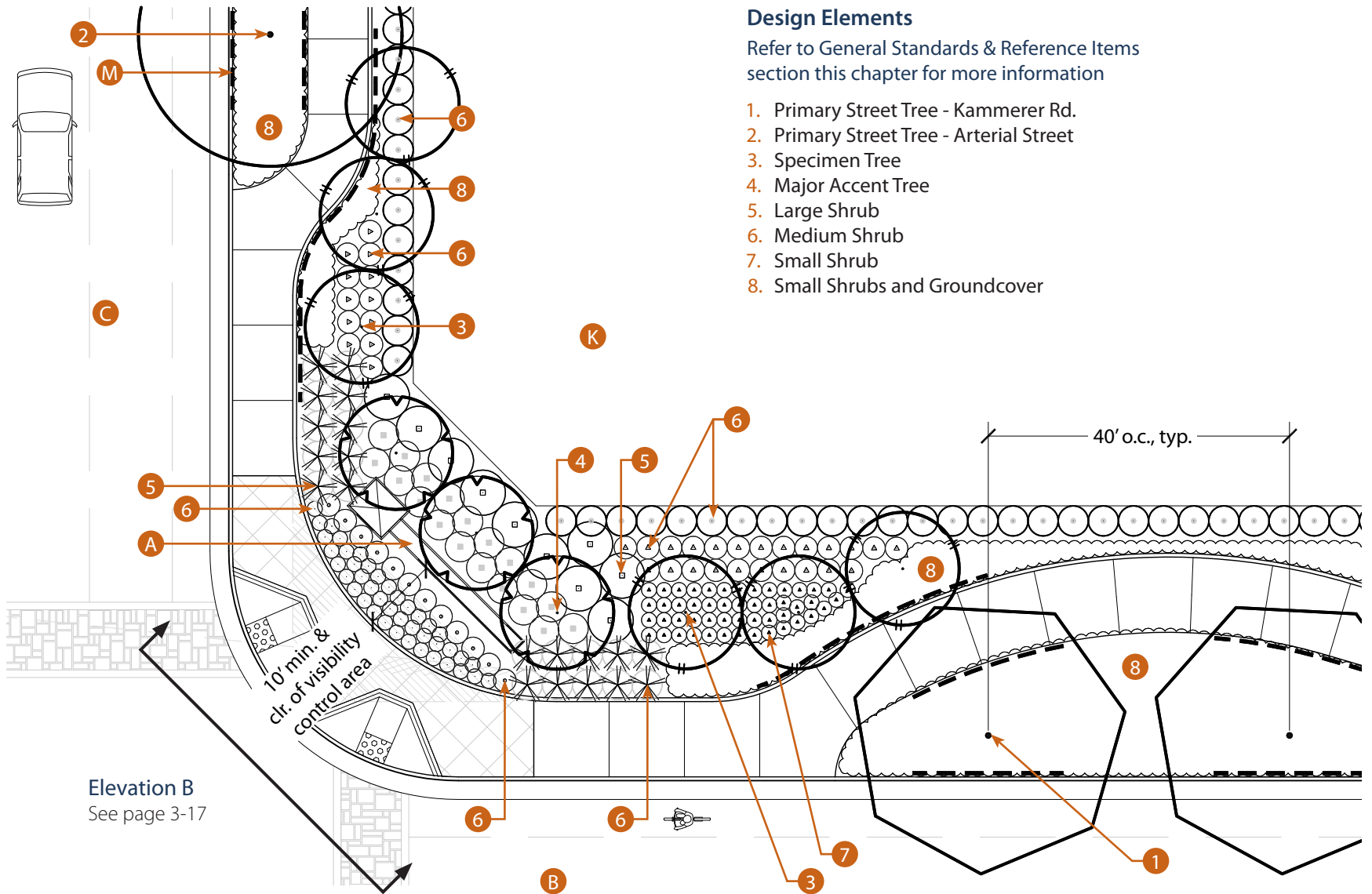

Design Elements

Refer to General Standards & Reference Items section this chapter for more information

- 1. Primary Street Tree - Kammerer Rd.
- 2. Primary Street Tree - Arterial Street
- 3. Specimen Tree
- 4. Major Accent Tree
- 5. Large Shrub
- 6. Medium Shrub
- 7. Small Shrub
- 8. Small Shrubs and Groundcover

Elevation B
See page 3-17

Primary Entry Monument - Plan Enlargement
Not to Scale

CHAPTER 3

ENTRY MONUMENTS, WALLS & FENCES: ENTRY MONUMENTS

5. Secondary Entry Monument

Secondary Entry Monuments are nearly identical in design and materials to that of the Primary Entry Monument, however they are slightly smaller in scale. Secondary Entry Monuments occur at specific Arterial Street intersections, including Kammerer Road, as one enters the Plan Area. Whenever possible, the Secondary Entry Monument shall be located on both sides of an intersection. Similar to the Primary Entry Monument, the Secondary Monument is a combination pilaster and monument wall, with a major signage feature. This monument has a CMU block internal structure creating the pilaster and wall and veneered with a manufactured stone on all sides of the monument. Both the pilaster and wall are capped by a custom precast concrete cap, sized specifically to each wall or pilaster element. The Secondary Entry Monument signage includes a metal wrap-around panel with lettering and metal medallion with logo. All elements of the Secondary Entry Monument shall be consistent throughout the entire Plan Area including stone, concrete caps and metal accents, as well as identical signage lettering, verbiage and logo. Refer to General Standards and Reference Items section in this chapter for more information.

Design Elements

Refer to General Standards & Reference Items section this chapter for more information

- A. Secondary Entry Monument (refer to Elevation B)
- B. Residential Collector (refer to Chapter 2)
- C. Concrete Sidewalk
- D. Community Wall
- E. Community Pilaster
- F. City of Elk Grove Type 3 Concrete Curb
- G. Landscaping, typ. (refer to Secondary Entry Monument Plan - Enlargement)
- H. Residential Land Use (refer to Special Planning Area Document, Chapter 2)

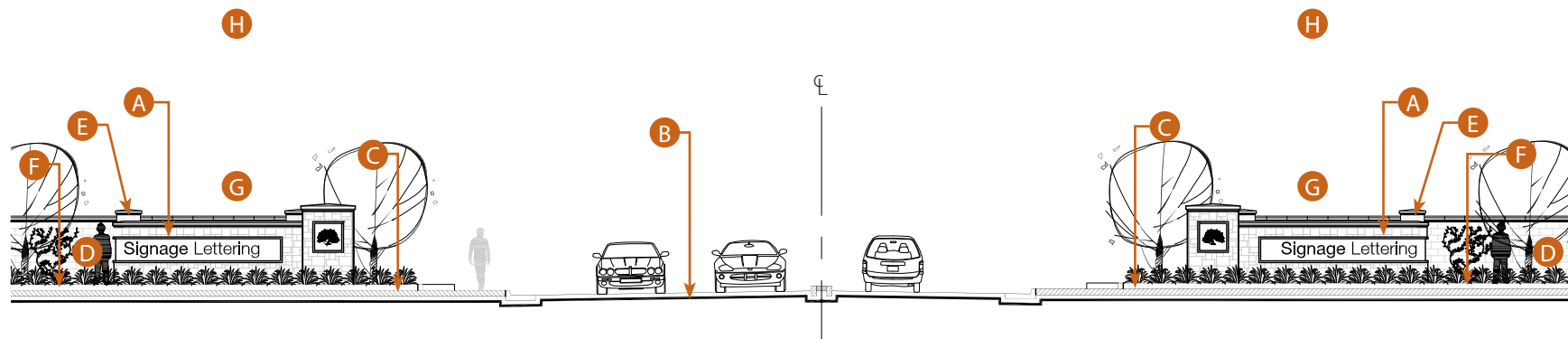

Secondary Entry Monument - Elevation A

Not to Scale

Design Elements

Refer to General Standards & Reference Items section this chapter for more information

- 1. Pilaster
- 2. Pilaster Cap
- 3. Metal Medallion
- 4. Wall
- 5. Wall Cap
- 6. Stone Veneer
- 7. Metal Wrap-Around Panel (refer to Metal Wrap-Around Panel Attachment detail)
- 8. Landscaping, typ. (not shown - refer to Secondary Entry Monument - Plan Enlargement)
- 9. Concrete Masonry Unit Block (CMU) at Monument
- 10. Stone Veneer Mortar Bed
- 11. Lettering Attached to Metal Wrap-Around Panel
- 12. Metal Wrap-Around Panel Attached to CMU Block
- 13. Lettering (TBD)
- 14. Logo (TBD)

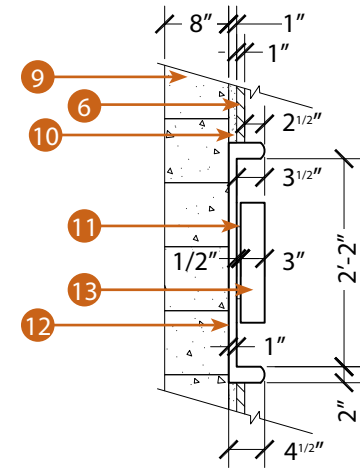

Metal Wrap-Around Panel Attachment

Not to Scale

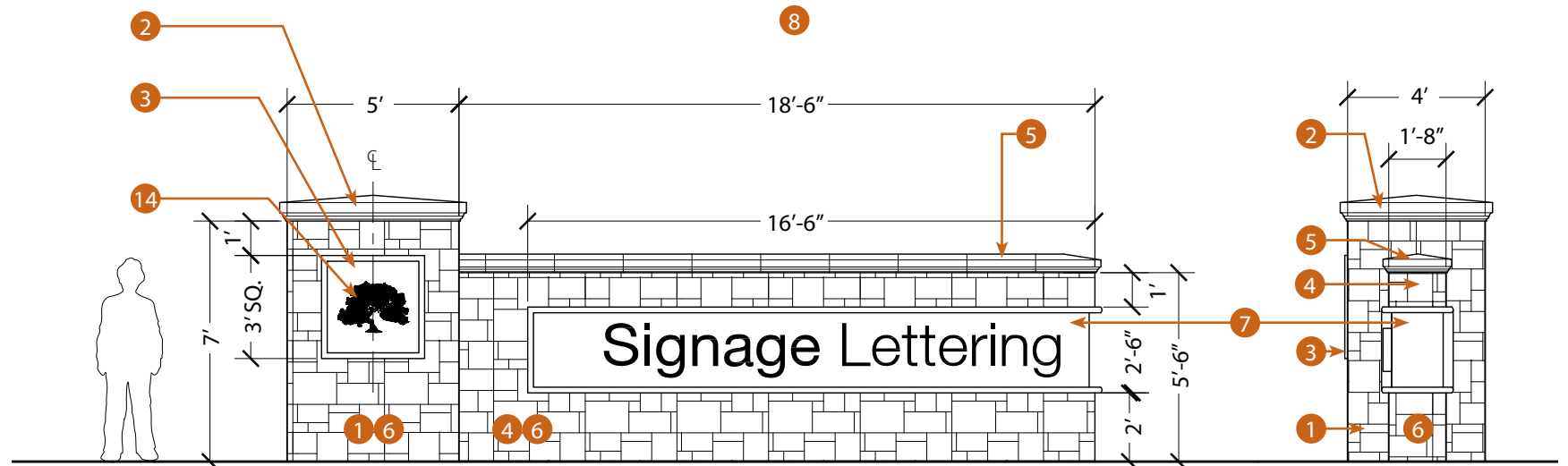

Secondary Entry Monument - Elevation B

Not to Scale

Secondary Entry Monument - Section

Not to Scale

CHAPTER 3

ENTRY MONUMENTS, WALLS & FENCES: ENTRY MONUMENTS

Design Elements

Refer to General Standards & Reference Items section this chapter for more information

- A. Secondary Entry Monument
- B. Community Wall with Community Pilaster
- C. Arterial Street (refer to Chapter 2)
- D. Residential Collector (refer to Chapter 2)
- E. Concrete Sidewalk
- F. Colored Concrete Enhanced Paving
- G. Colored Stamped Asphalt Enhanced Paving Crosswalk
- H. City of Elk Grove Type 3 Concrete Curb
- I. City of Elk Grove Visibility Control Area
- J. Colored Stamped Concrete Maintenance Safety Strip at Landscape Median/Turn Pocket
- K. Landscaping, typ. (refer to Secondary Monument - Plan Enlargement)
- L. Residential Land Use (refer to Special Planning Area Document, Chapter 2)
- M. Tree Root Barrier

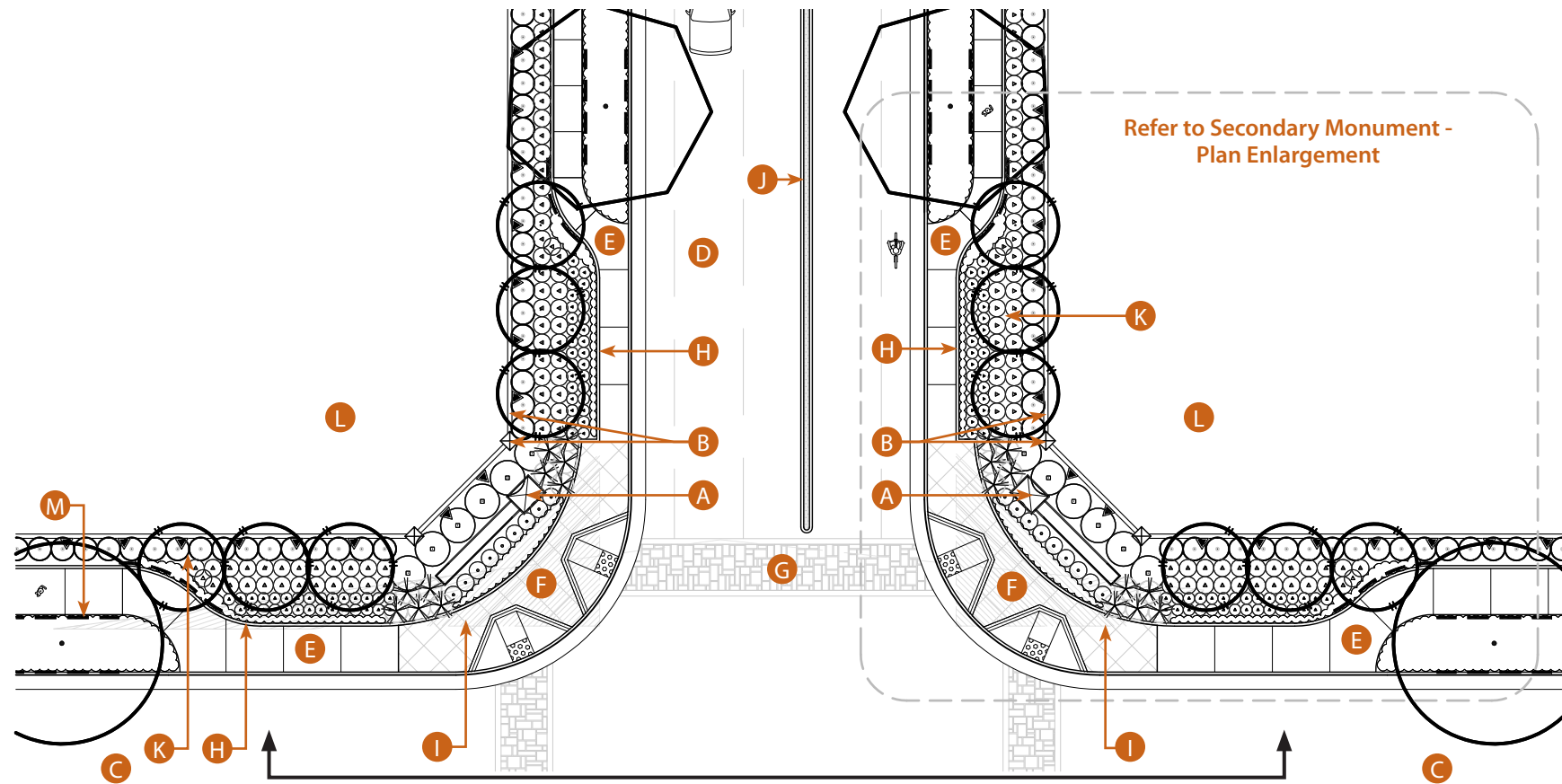

Secondary Entry Monument - Plan

Not to Scale

Elevation A

See page 3-20

Design Elements

Refer to General Standards & Reference Items section this chapter for more information

- 1. Primary Street Tree - Arterial Street
- 2. Primary Street Tree - Residential Collector
- 3. Specimen Tree
- 4. Large Shrub
- 5. Medium Shrub
- 6. Small Shrub
- 7. Small Shrubs & Groundcover
- 8. Vine

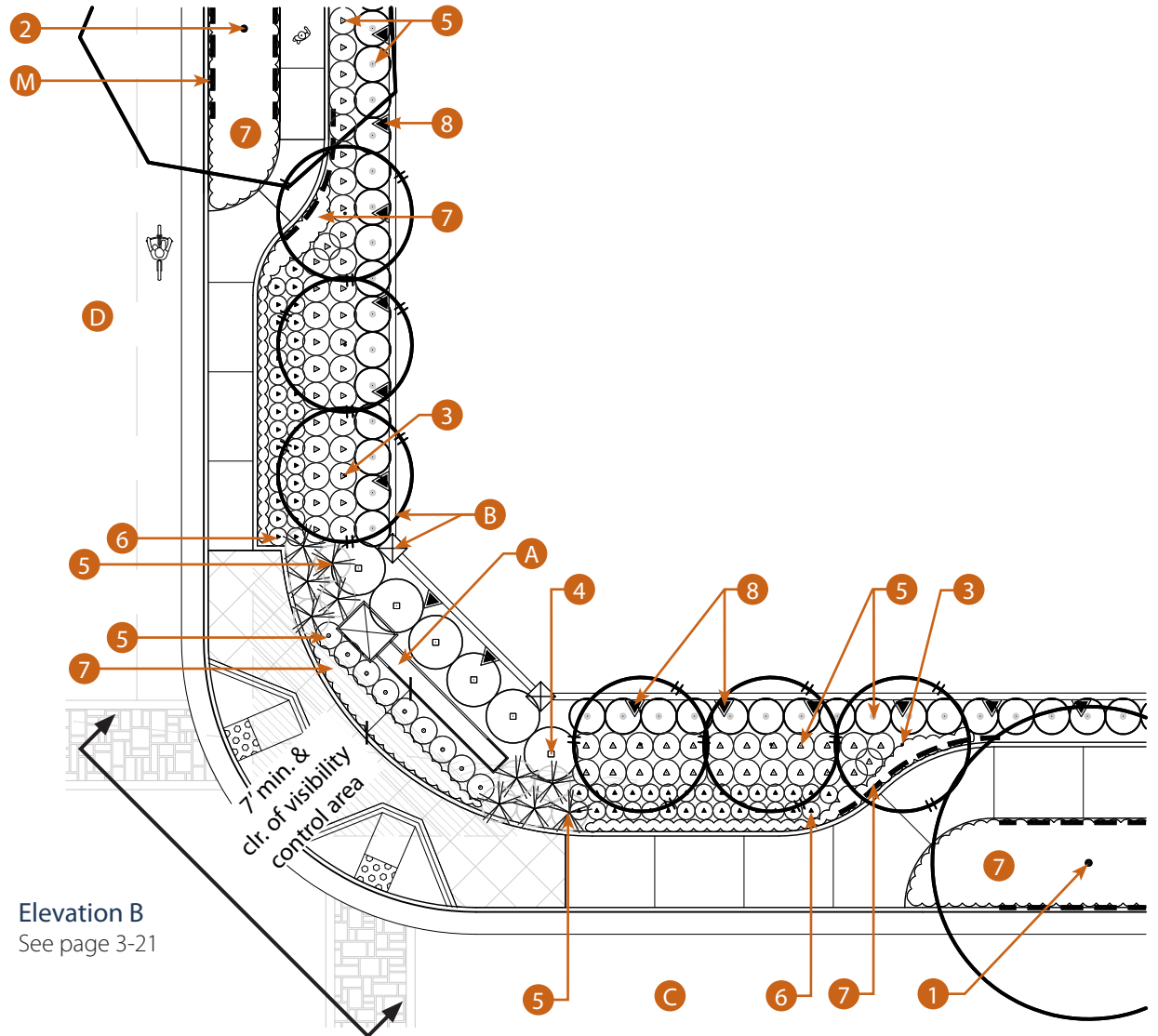

Elevation B
See page 3-21

Secondary Entry Monument - Plan Enlargement
Not to Scale

6. Neighborhood Entry Monument Overview

Neighborhood Entry Monuments convey to the user they have entered a specific residential neighborhood within the Plan Area. These monuments occur at Arterial and residential land use street intersections, and vary in size and scale depending on the particular street dimensions, residential product type, and appropriate branding and marketing of the residential product type. The intent of the Neighborhood Entry Monument is not to require one particular Neighborhood Entry Monument at every residential neighborhood intersection, but to allow the landowner or residential unit builder to select the monument that best conveys their product type and best fits within the constraints of each street and intersection. Whenever possible, Neighborhood Entry Monuments shall be located on both sides of a street or intersection. Additionally, Neighborhood Entry Monuments may be used in combination with Secondary Entry Monuments where Arterial Streets intersect with a Collector Residential Streets. The landowner or residential unit builder shall name their individual community and create a logo for their community, which shall be located on the entry monument(s) within their project area. The specific content and verbiage of the lettering and logos contained on Neighborhood Entry Monuments shall be proposed by the landowner or residential unit builder and approved by the City. Although Neighborhood Entry Monuments vary slightly in materials, size and scale, all monuments shall use the exact same stone, concrete caps and type of metal, consistent throughout the entire Plan Area. Neighborhood Entry Monuments are not required but are strongly encouraged to promote the Plan Area’s design aesthetic and distinct identity.

7. Neighborhood Entry Monument #1

Neighborhood Entry Monument #1 uses a combination of pilasters, low walls and metal panels, with varied community signage. These monuments have a CMU block internal structure creating the pilaster and low wall, and veneered with a manufactured stone on all sides of the monument. Both the pilaster and walls are capped by a custom precast concrete cap, sized specifically to each pilaster and low wall element. Neighborhood Entry Monument #1 includes a metal wrap-around panel with lettering and logo and a metal grid panel. Refer to Neighborhood Entry Monument Overview as well as General Standards and Reference Items sections in this chapter for more information.

Design Elements

Refer to General Standards & Reference Items section this chapter for more information

- A. Neighborhood Entry Monument #1 (refer to Elevation B)
- B. Residential Collector (or Local Residential Street)
- C. Concrete Sidewalk
- D. Community Wall
- E. Community Pilaster
- F. City of Elk Grove Type 3 Concrete Curb
- G. Landscaping, typ. (refer to Neighborhood Entry Monument #1 Plan - Enlargement)
- H. Residential Land Use (refer to Special Planning Area Document, Chapter 2)

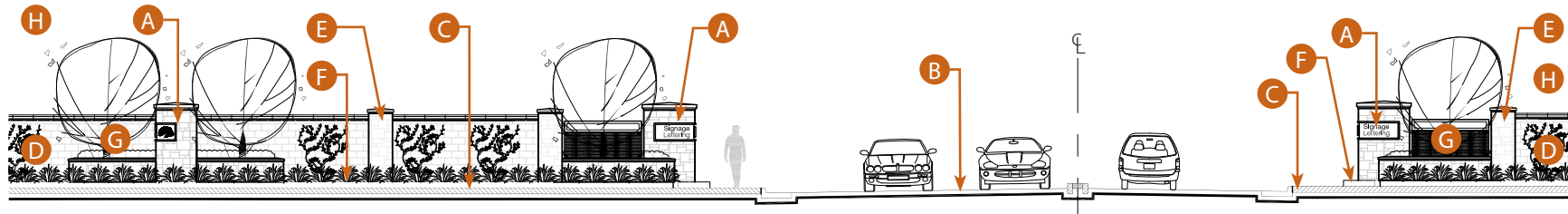

Neighborhood Entry Monument #1 - Elevation A
Not to Scale

Design Elements

Refer to General Standards & Reference Items section this chapter for more information

- | | |
|---|---|
| <ul style="list-style-type: none"> 1. Pilaster 2. Pilaster Cap 3. Wall 4. Wall Cap 5. Metal Grid Panel 6. Stone Veneer 7. Raised Planter Bed 8. Metal Wrap-Around Panel
(refer to Metal Wrap-Around Panel Attachment detail) 9. Landscaping, typ. (not shown - refer to Neighborhood Entry Monument #1 - Plan Enlargement) | <ul style="list-style-type: none"> 10. Concrete Masonry Unit Block (CMU) at Monument 11. Stone Veneer Mortar Bed 12. Lettering Attached to Metal Wrap-Around Panel 13. Metal Wrap-Around Panel Attached to CMU Block 14. Lettering (TBD) 15. Logo (TBD) 16. Community Pilaster 17. Community Wall |
|---|---|

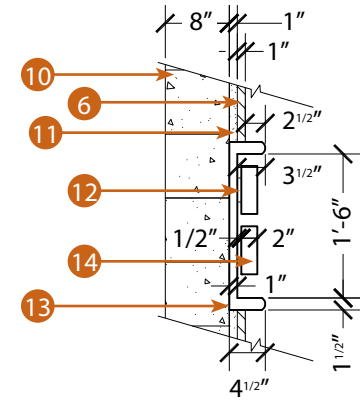

Metal Wrap-Around Panel Attachment
Not to Scale

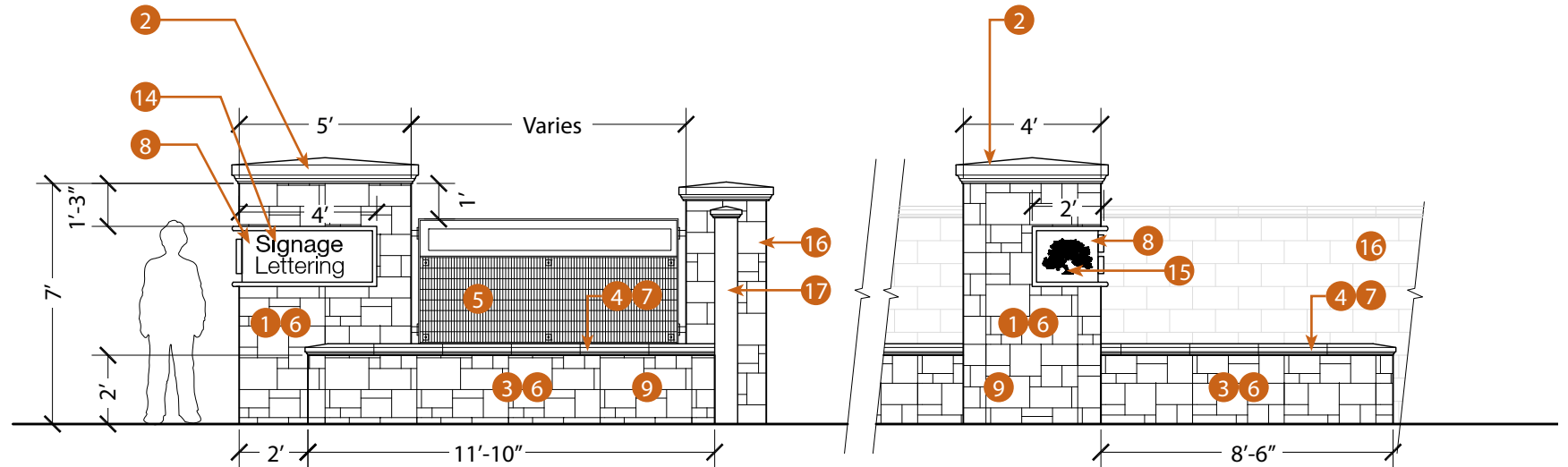

Neighborhood Entry Monument #1 - Elevation B
Not to Scale

Neighborhood Entry Monument #1 - Section
Not to Scale

CHAPTER 3

ENTRY MONUMENTS, WALLS & FENCES: ENTRY MONUMENTS

Design Elements

Refer to General Standards & Reference Items section this chapter for more information

- A. Neighborhood Entry Monument #1
- B. Community Wall
- C. Community Pilaster
- D. Arterial Street (or Residential Collector Street)
- E. Residential Collector Street (or Local Residential Street)
- F. Concrete Sidewalk
- G. Colored Concrete Enhanced Paving
- H. Colored Stamped Asphalt Enhanced Paving Crosswalk (if Arterial Street)
- I. City of Elk Grove Type 3 Concrete Curb
- J. City of Elk Grove Visibility Control Area
- K. Colored Stamped Concrete Maintenance Safety Strip at Landscape Median/Turn Pocket
- L. Landscaping, typ. (refer to Neighborhood Entry #1 Monument - Plan Enlargement)
- M. Residential Land Use (refer to Special Planning Area Document, Chapter 2)
- N. Tree Root Barrier

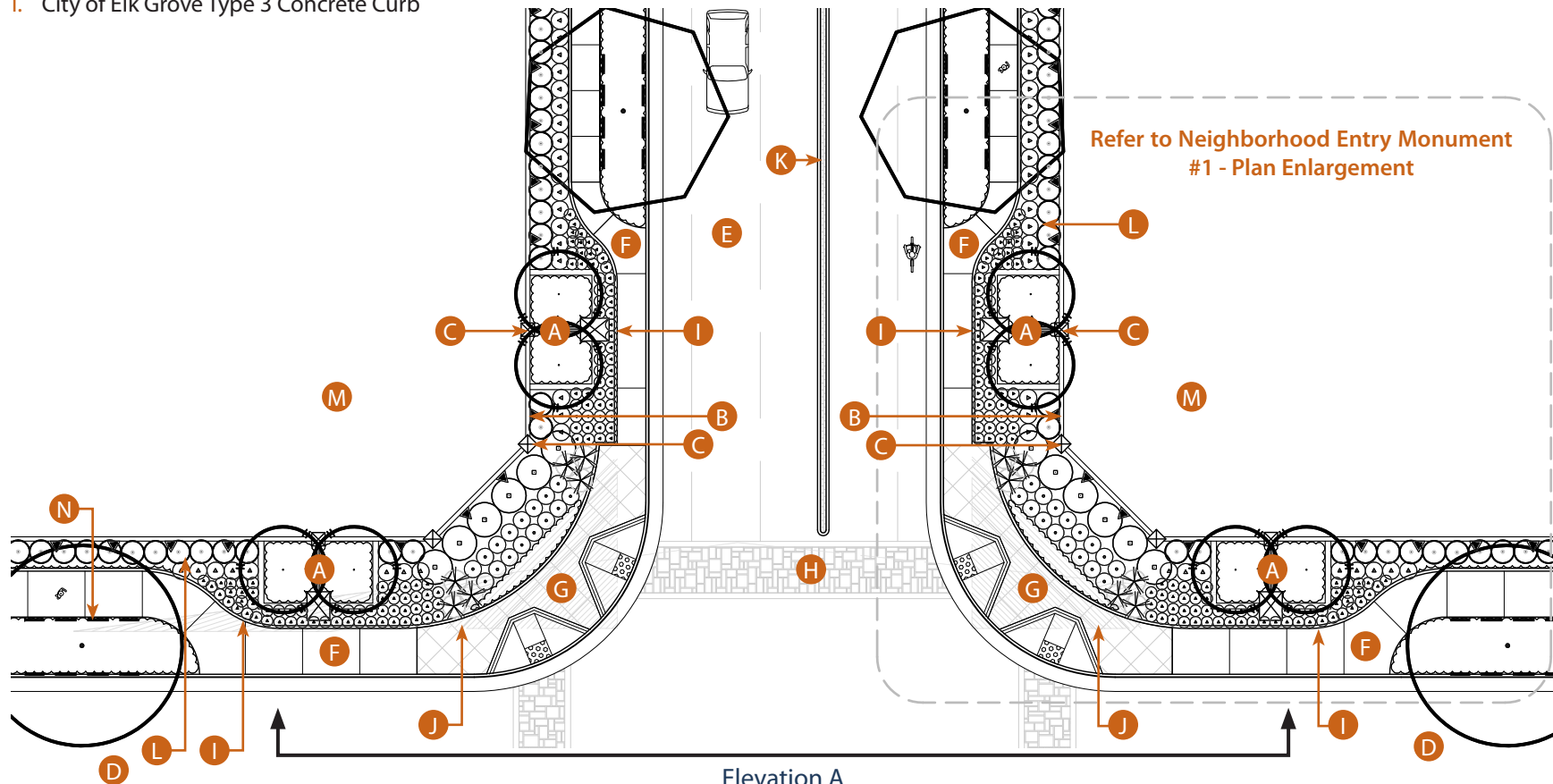

Neighborhood Entry Monument #1 - Plan
Not to Scale

Elevation A
See page 3-24

Design Elements

Refer to General Standards & Reference Items section this chapter for more information

- 1. Primary Street Tree - Arterial Street or Residential Collector
- 2. Primary Street Tree - Residential Collector or Local Residential
- 3. Specimen Tree
- 4. Large Shrub
- 5. Medium Shrub
- 6. Small Shrub
- 7. Small Shrubs & Groundcover
- 8. Vine

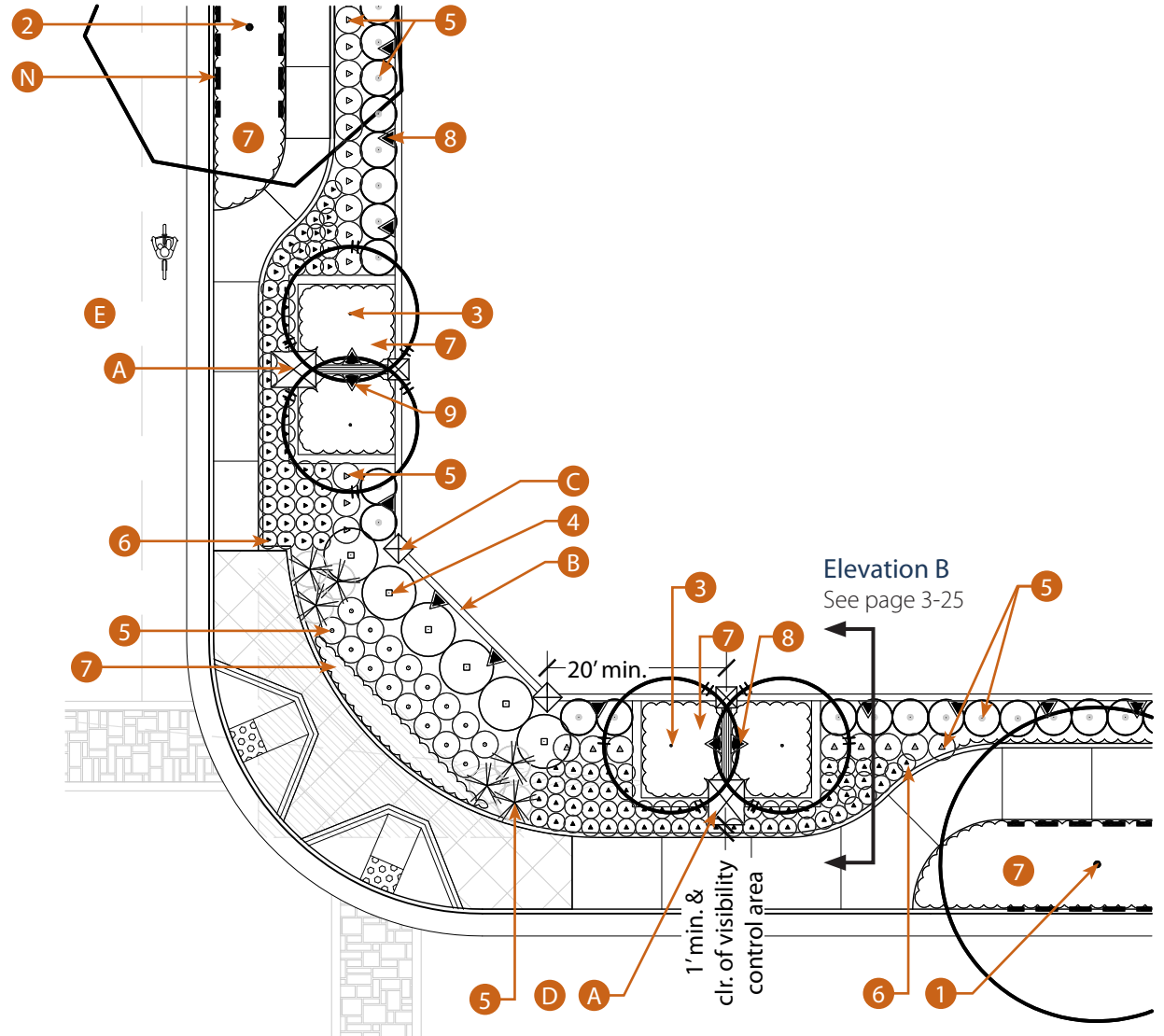

Neighborhood Entry Monument #1- Plan Enlargement
Not to Scale

CHAPTER 3

ENTRY MONUMENTS, WALLS & FENCES: ENTRY MONUMENTS

8. Neighborhood Entry Monument #2

Neighborhood Entry Monument #2 uses a combination of pilasters, low walls and metal panels, with varied community signage. These monuments have a CMU block internal structure creating the pilaster and low wall, and veneered with a manufactured stone on all sides of the monument. Both the pilaster and walls are capped by a custom precast concrete cap, sized specifically to each pilaster and low wall element. Neighborhood Entry Monument #2 includes a metal wrap-around panel with lettering and logo and a metal grid panel. Refer to Neighborhood Entry Monument Overview as well as General Standards and Reference Items sections in this chapter for more information.

Design Elements

Refer to General Standards & Reference Items section this chapter for more information

- A. Neighborhood Entry Monument #1 (refer to Elevation B)
- B. Arterial Street (or Residential Collector)
- C. Concrete Sidewalk
- D. Community Wall
- E. Community Pilaster
- F. City of Elk Grove Type 3 Concrete Curb
- G. Landscaping, typ. (refer to Neighborhood Entry Monument #2 Plan - Enlargement)
- H. Residential Land Use (refer to Special Planning Area Document, Chapter 2)

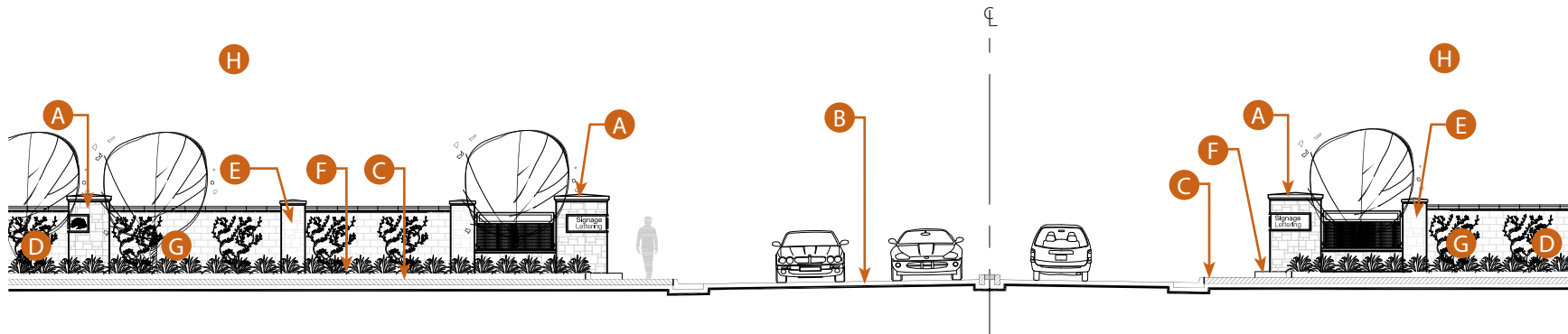

Neighborhood Entry Monument #2 - Elevation A

Not to Scale

Design Elements

Refer to General Standards & Reference Items section this chapter for more information

- | | |
|---|---|
| 1. Pilaster | 9. Concrete Masonry Unit Block (CMU) at Monument |
| 2. Pilaster Cap | 10. Stone Veneer Mortar Bed |
| 3. Wall | 11. Lettering Attached to Metal Wrap-Around Panel |
| 4. Wall Cap | 12. Metal Wrap-Around Panel Attached to CMU Block |
| 5. Metal Grid Panel | 13. Lettering (TBD) |
| 6. Stone Veneer | 14. Logo (TBD) |
| 7. Metal Wrap-Around Panel (refer to Metal Wrap-Around Panel Attachment detail) | 15. Community Pilaster |
| 8. Landscaping, typ. (not shown - refer to Neighborhood Entry Monument #2 - Plan Enlargement) | 16. Community Wall |

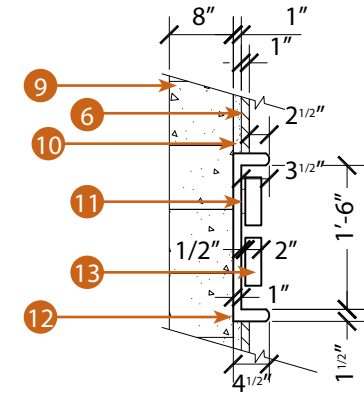

Metal Wrap-Around Panel Attachment

Not to Scale

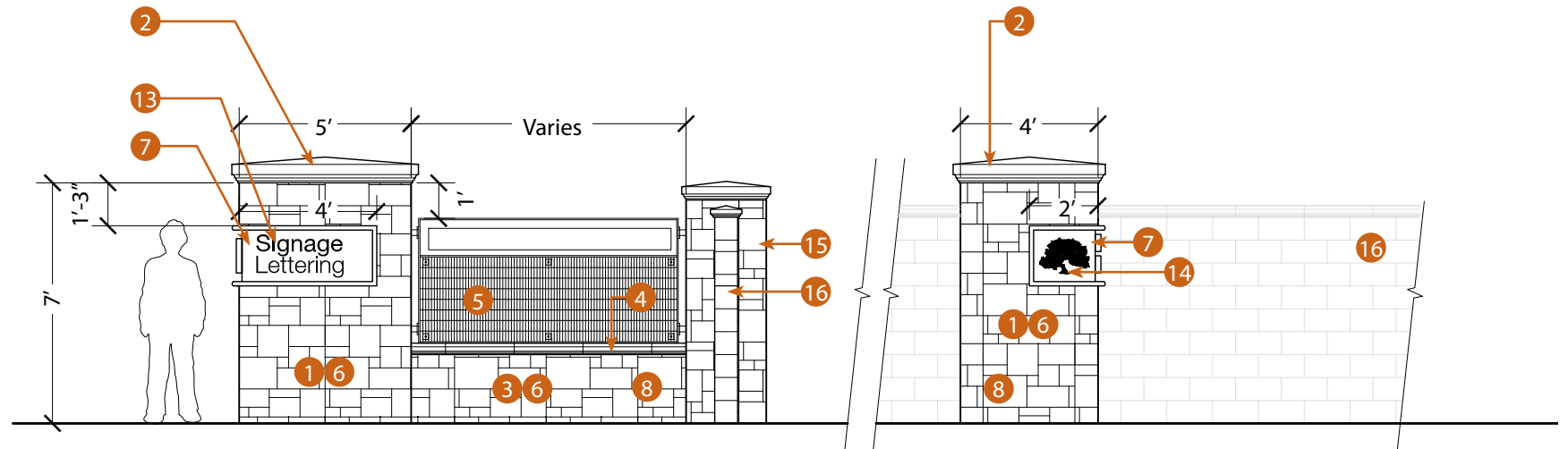

Neighborhood Entry Monument #2 - Elevation B

Not to Scale

Neighborhood Entry Monument #2 - Section

Not to Scale

CHAPTER 3

ENTRY MONUMENTS, WALLS & FENCES: ENTRY MONUMENTS

Design Elements

Refer to General Standards & Reference Items section this chapter for more information

- A. Neighborhood Entry Monument #2
- B. Community Wall
- C. Community Pilaster
- D. Arterial Street (or Residential Collector)
- E. Residential Collector (or Local Residential Street)
- F. Concrete Sidewalk
- G. Colored Concrete Enhanced Paving
- H. Colored Stamped Asphalt Enhanced Paving Crosswalk (if Arterial Street)
- I. City of Elk Grove Type 3 Concrete Curb
- J. City of Elk Grove Visibility Control Area
- K. Colored Stamped Concrete Maintenance Safety Strip at Landscape Median/Turn Pocket
- L. Landscaping, typ. (refer to Neighborhood Entry Monument #2 - Plan Enlargement)
- M. Residential Land Use (refer to Special Planning Area Document, Chapter 2)
- N. Tree Root Barrier

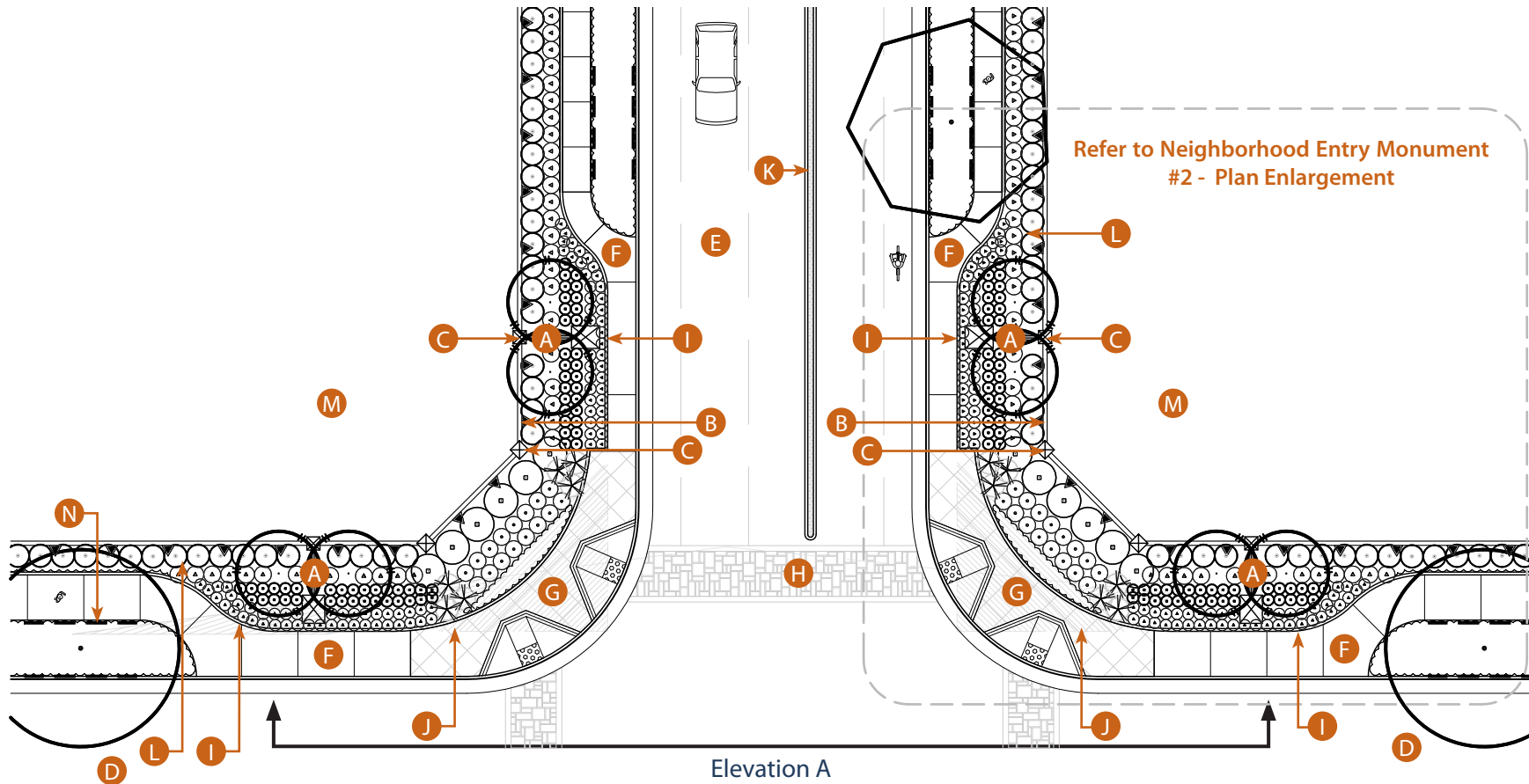

Neighborhood Entry Monument #2 - Plan

Not to Scale

CHAPTER 3

ENTRY MONUMENTS, WALLS & FENCES: ENTRY MONUMENTS

9. Neighborhood Entry Monument #3

Neighborhood Entry Monument #3 uses a combination of a pilaster, low wall and metal medallion/panel, with varied community signage. These monuments have a CMU block internal structure creating the pilaster and low wall, and veneered with a manufactured stone on all sides of the monument. Both the pilaster and walls are capped by a custom precast concrete cap, sized specifically to each pilaster and low wall element. Neighborhood Entry Monument #3 includes a metal medallion with lettering and a metal grid panel. Refer to Neighborhood Entry Monument Overview as well as General Standards and Reference Items sections in this chapter for more information.

Design Elements

Refer to General Standards & Reference Items section this chapter for more information

- A. Neighborhood Entry Monument #3 (refer to Elevation B)
- B. Local Residential Street
- C. Concrete Sidewalk
- D. Community Wall
- E. Community Pilaster
- F. City of Elk Grove Type 3 Concrete Curb
- G. Landscaping, typ. (refer to Neighborhood Entry Monument #3 - Plan Enlargement)
- H. Residential Land Use (refer to Special Planning Area Document, Chapter 2)

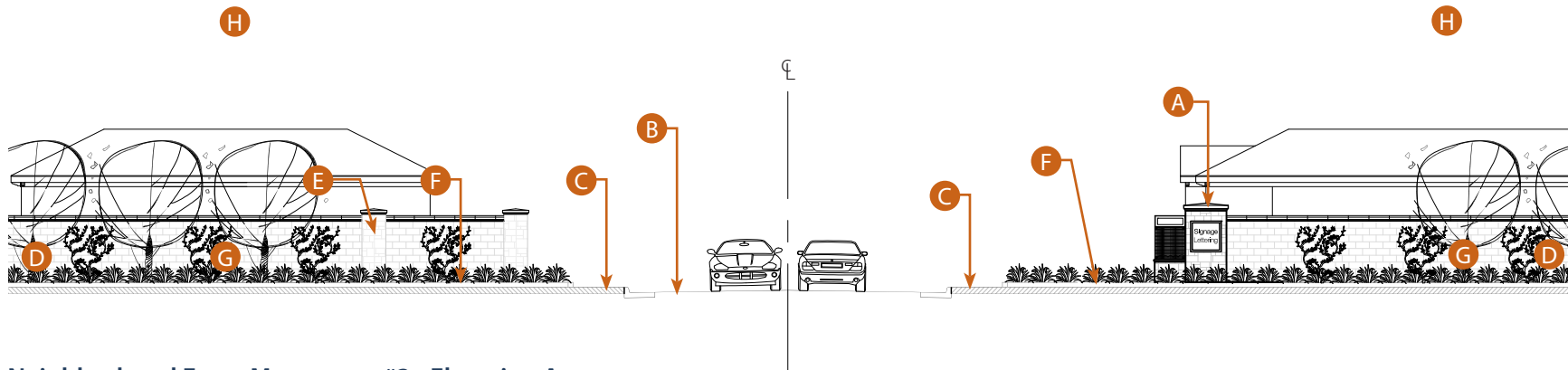

Neighborhood Entry Monument #3 - Elevation A

Not to Scale

Design Elements

Refer to General Standards & Reference Items section this chapter for more information

- | | |
|---|--|
| 1. Pilaster | 9. Concrete Masonry Unit Block (CMU) at Monument |
| 2. Pilaster Cap | 10. Stone Veneer Mortar Bed |
| 3. Wall | 11. Lettering Attached to Metal Panel |
| 4. Wall Cap | 12. Metal Panel Attached to CMU Block |
| 5. Metal Grid Panel | 13. Lettering (TBD) |
| 6. Stone Veneer | 14. Logo (TBD) |
| 7. Metal Panel (refer to Metal Panel Attachment detail) | 15. Community Pilaster |
| 8. Landscaping, typ. (not shown - refer to Neighborhood Entry Monument #3 - Plan Enlargement) | 16. Community Wall |

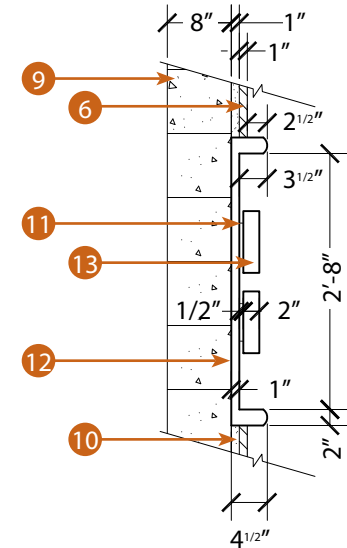

Metal Panel Attachment
Not to Scale

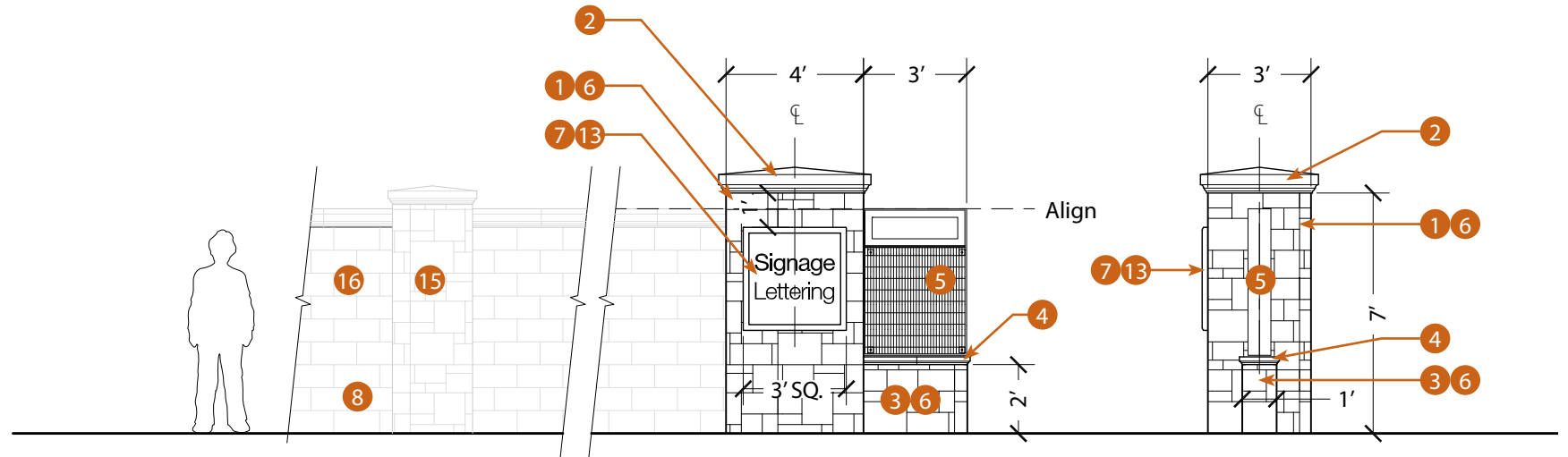

Neighborhood Entry Monument #3 - Elevation B
Not to Scale

Neighborhood Entry Monument #3 - Section
Not to Scale

CHAPTER 3

ENTRY MONUMENTS, WALLS & FENCES: ENTRY MONUMENTS

Design Elements

Refer to General Standards & Reference Items section this chapter for more information

- A. Neighborhood Entry Monument #3
- B. Community Wall
- C. Community Pilaster
- D. Residential Wood Fence
- E. Residential Collector
- F. Local Residential Street
- G. Concrete Sidewalk
- H. City of Elk Grove Type 3 Concrete Curb
- I. City of Elk Grove Visibility Control Area
- J. Colored Stamped Concrete Maintenance Safety Strip at Landscape Median/Turn Pocket
- K. Edging for Residential Lots
- L. Primary Streetlight
- M. Landscaping, typ. (refer to Neighborhood Entry Monument #3 - Plan Enlargement)
- N. Residential Land Use (refer to Special Planning Area Document, Chapter 2)

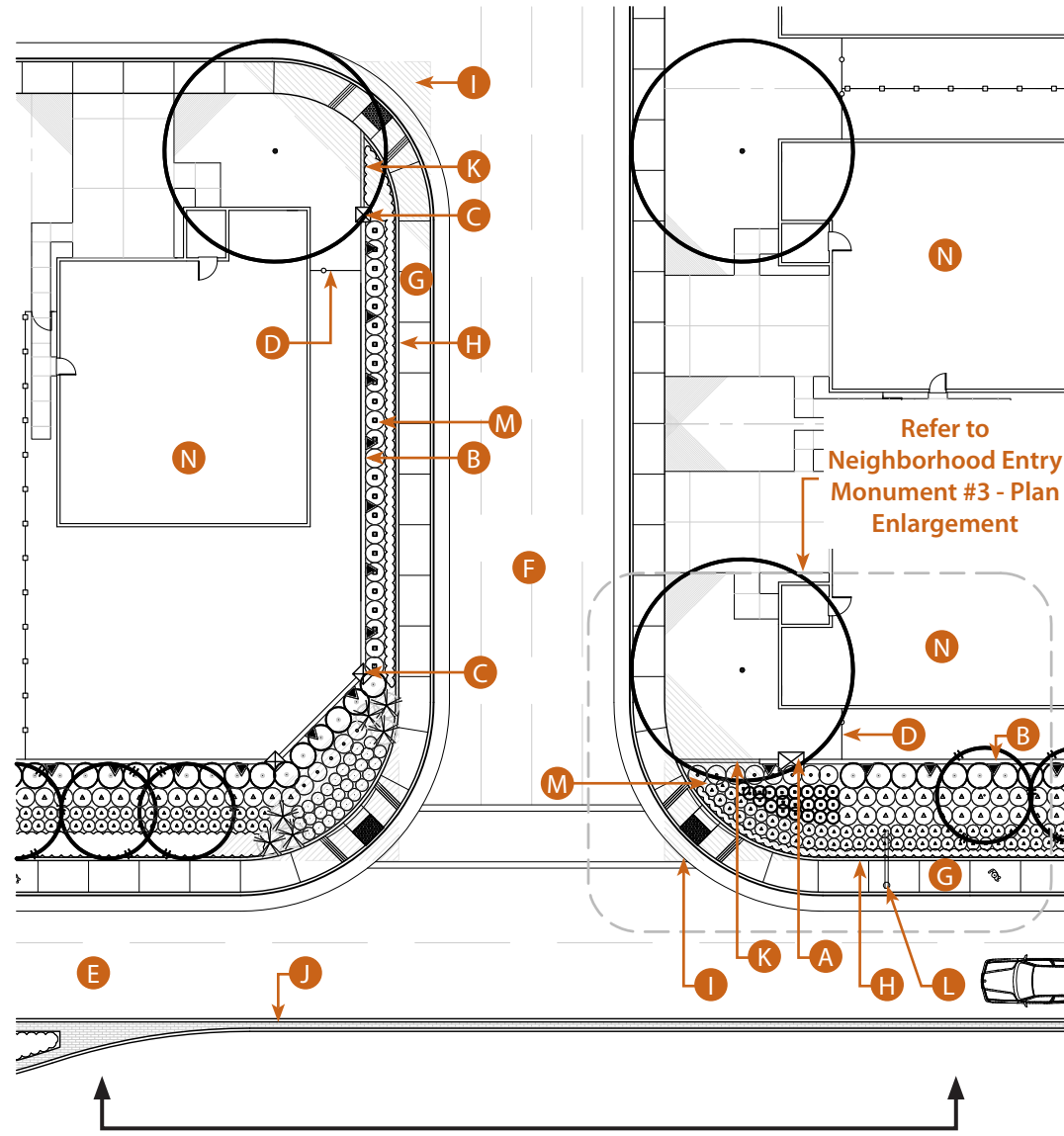

Neighborhood Entry Monument #3 - Plan
Not to Scale

Design Elements

Refer to General Standards & Reference Items section this chapter for more information

- 1. Primary Street Tree - Local Residential
- 2. Accent Tree
- 3. Large Shrub (not shown)
- 4. Medium Shrub
- 5. Small Shrub
- 6. Small Shrubs & Groundcover
- 7. Residential Unit Front Yard Landscaping
- 8. Vine

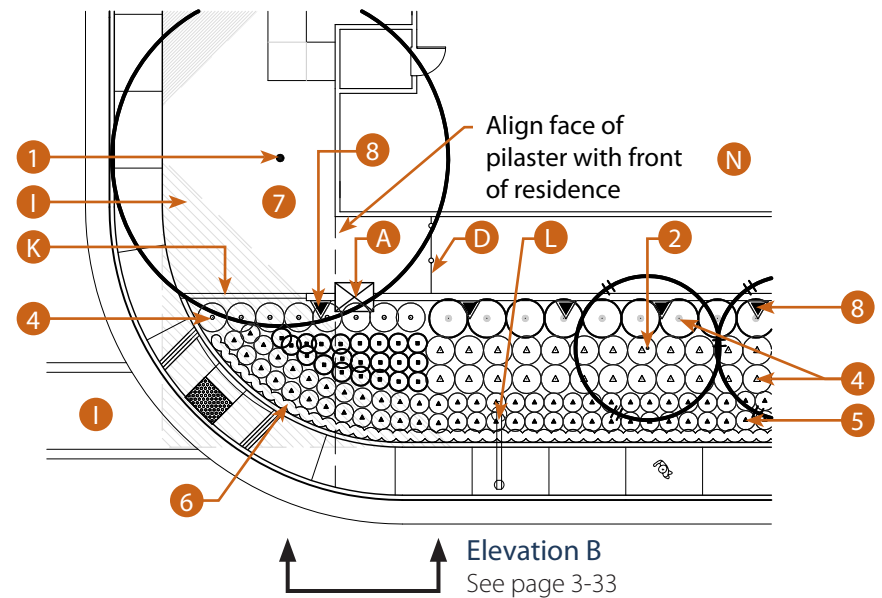

Neighborhood Entry Monument #3 - Plan Enlargement

Not to Scale

CHAPTER 3

ENTRY MONUMENTS, WALLS & FENCES: ENTRY MONUMENTS

10. Neighborhood Entry Monument #4

Neighborhood Entry Monument #4 uses a combination of a pilaster and metal panel with varied community signage. These monuments have a CMU block internal structure creating the pilaster and veneered with a manufactured stone on all sides of the monument. The pilaster is capped by a custom precast concrete cap, sized specifically to the pilaster. Neighborhood Entry Monument #4 includes a metal wrap-around lettering and logo. Refer to Neighborhood Entry Monument Overview as well as General Standards and Reference Items sections in this chapter for more information.

Design Elements

Refer to General Standards & Reference Items section this chapter for more information

- A. Neighborhood Entry Monument #4 (refer to Elevation A)
- B. Local Residential Street
- C. Concrete Sidewalk
- D. Community Wall
- E. Community Pilaster
- F. City of Elk Grove Type 3 Concrete Curb
- G. Landscaping, typ. (refer to Neighborhood Entry Monument #4 - Plan Enlargement)
- H. Residential Land Use (refer to Special Planning Area Document, Chapter 2)

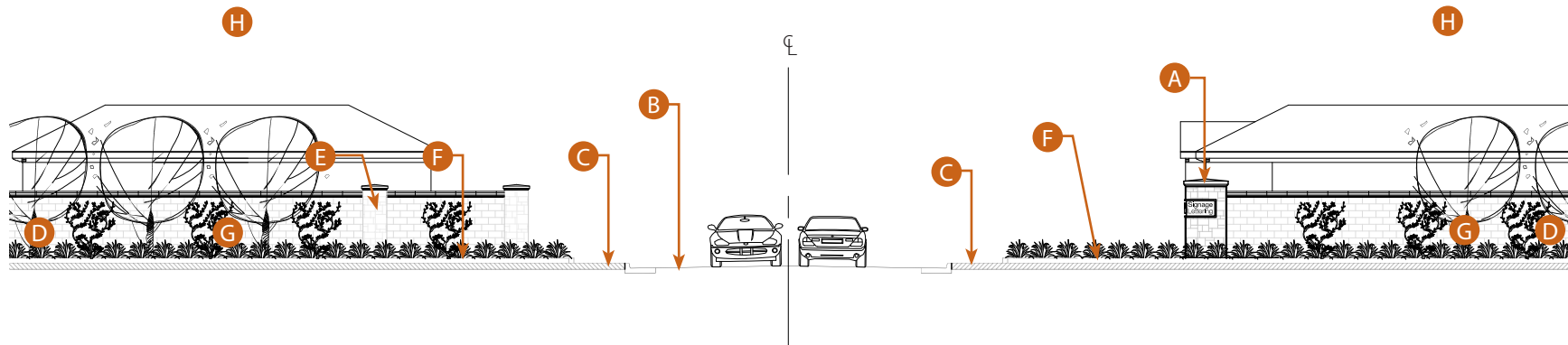

Neighborhood Entry Monument #4 - Elevation A

Not to Scale

Design Elements

Refer to General Standards & Reference Items section this chapter for more information

- | | |
|---|---|
| 1. Pilaster | 7. Stone Veneer Mortar Bed |
| 2. Pilaster Cap | 8. Lettering Letter Attached to Metal Wrap-Around Panel |
| 3. Stone Veneer | 9. Metal Wrap-Around Panel Attached to CMU Block |
| 4. Metal Wrap-Around Panel (refer to Metal Wrap-Around Panel Attachment detail) | 10. Lettering (TBD) |
| 5. Landscaping, typ. (not shown - refer to Neighborhood Entry Monument #4 - Plan Enlargement) | 11. Logo (TBD) |
| 6. Concrete Masonry Unit Block (CMU) at Monument | 12. Community Pilaster |
| | 13. Community Wall |

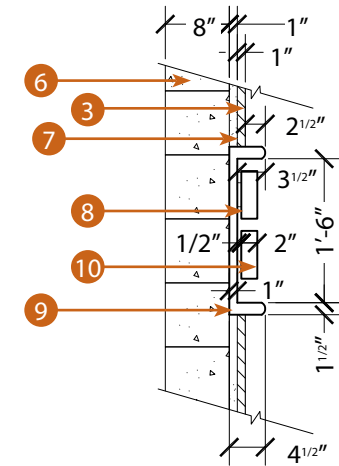

Metal Wrap-Around Panel Attachment

Not to Scale

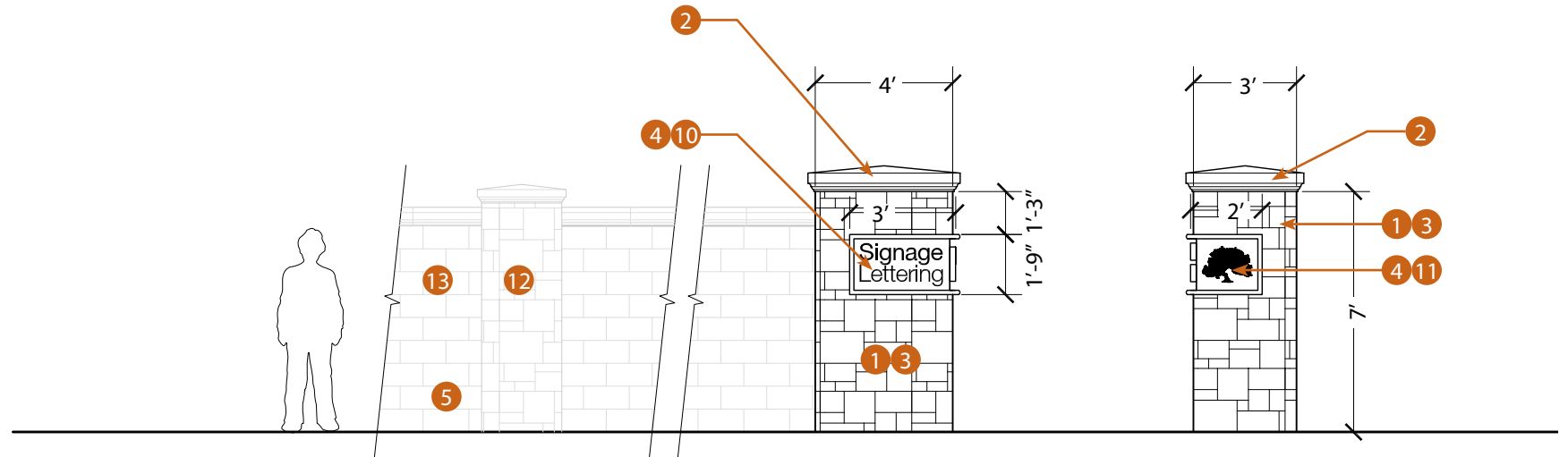

Neighborhood Entry Monument #4 - Elevation B

Not to Scale

Neighborhood Entry Monument #4 - Section

Not to Scale

CHAPTER 3

ENTRY MONUMENTS, WALLS & FENCES: ENTRY MONUMENTS

Design Elements

Refer to General Standards & Reference Items section this chapter for more information

- A. Neighborhood Entry Monument #4
- B. Community Wall
- C. Community Pilaster
- D. Residential Wood Fence
- E. Residential Collector
- F. Local Residential Street
- G. Concrete Sidewalk
- H. City of Elk Grove Type 3 Concrete Curb
- I. City of Elk Grove Visibility Control Area
- J. Colored Stamped Concrete Maintenance Safety Strip at Landscape Median/Turn Pocket
- K. Edging for Residential Lots
- L. Primary Streetlight
- M. Landscaping, typ. (refer to Neighborhood Entry Monument #4 - Plan Enlargement)
- N. Residential Land Use (refer to Special Planning Area Document, Chapter 2)

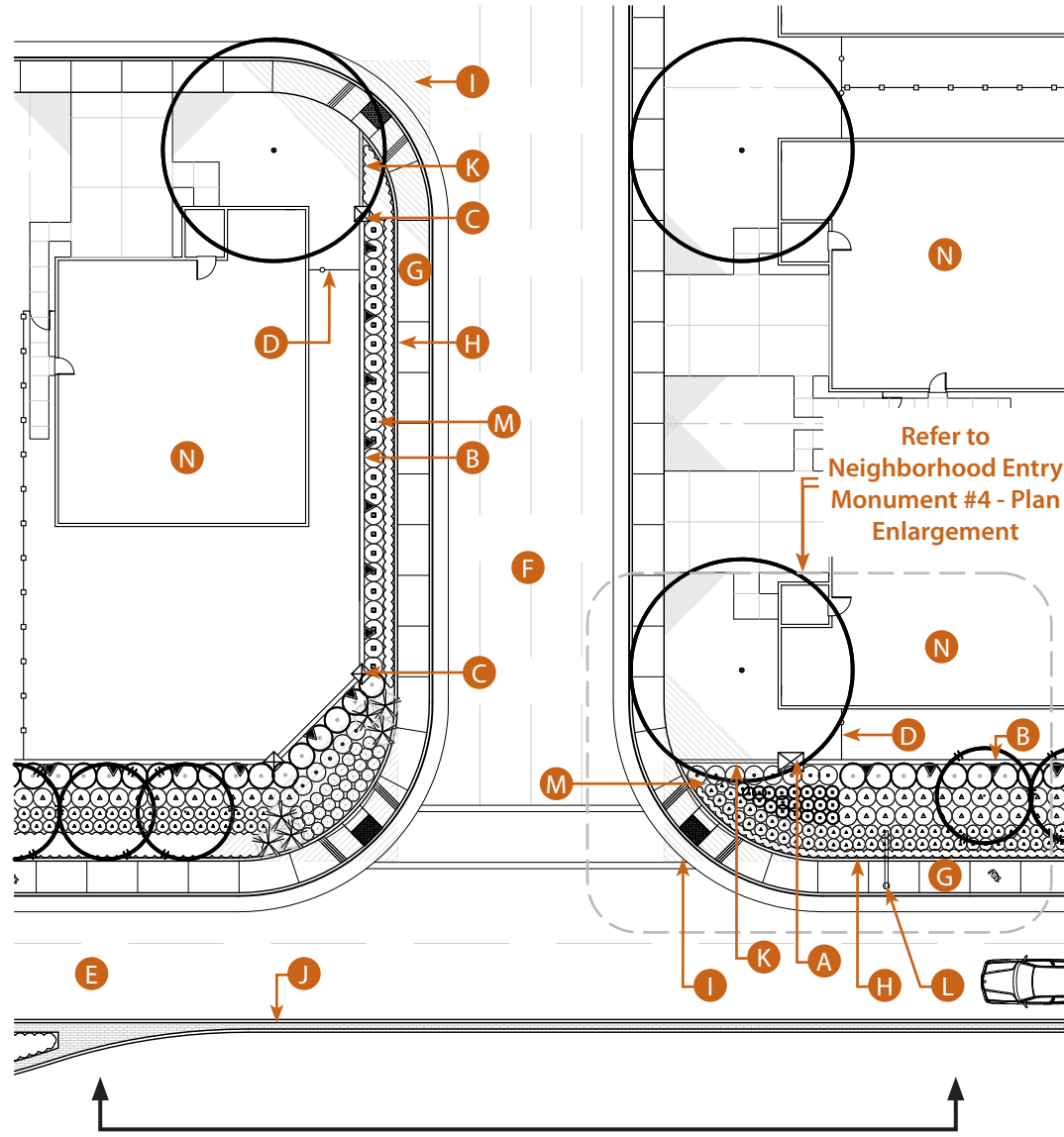

Neighborhood Entry Monument #4 - Plan
Not to Scale

Elevation A
See page 3-36

Design Elements

Refer to General Standards & Reference Items section this chapter for more information

- 1. Primary Street Tree - Local Residential
- 2. Accent Tree
- 3. Large Shrub (not shown)
- 4. Medium Shrub
- 5. Small Shrub
- 6. Small Shrubs & Groundcover
- 7. Residential Unit Front Yard Landscaping
- 8. Vine

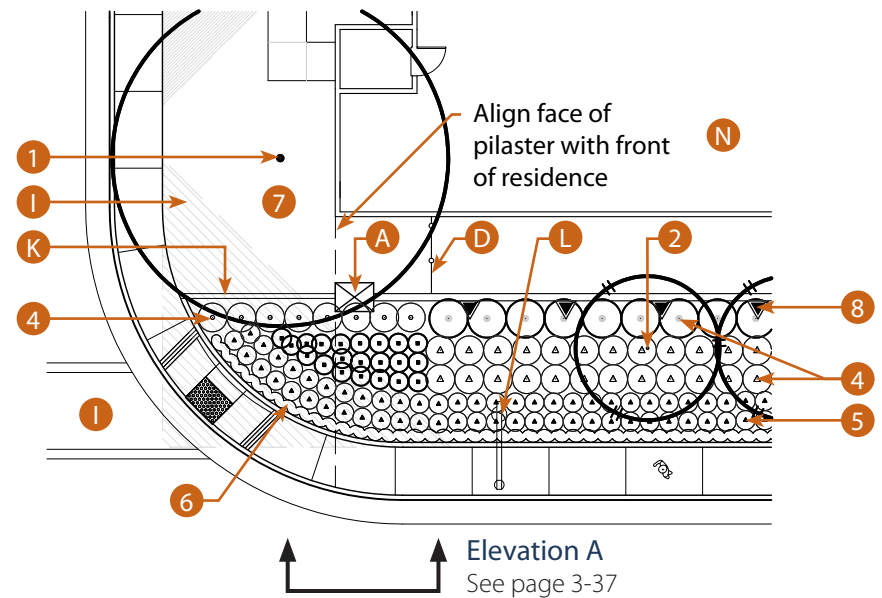

Neighborhood Entry Monument #4 - Plan Enlargement

Not to Scale

11. Gateway Features

Gateway features are free-standing monuments that signify entry into unique sections of the Plan Area. The design of each gateway feature shall be consistent with the Plan Area's surrounding architectural or natural features. Locations and design of all gateway features shall be as directed by the City.

12. Employment Area Entry Monument

Employment Area Entry Monuments are the primary signage (including lettering and logos) for office and light industrial/flex land uses within the Plan Area. Employment Area Entry Monuments shall be located near the primary driveway entrance into the office or light industrial/flex project. Additionally, Employment Area Entry Monuments may be located within the interior project site of each office and light industrial/flex land uses in order to provide the user a means of locating the specific tenant.

The height, width and scale of each Employment Area Entry Monument may vary depending on the project type and land use. The employment area monumentation lettering may be modified as necessary to fit the particular land use and final building product on the project site. The guidelines represented in this section are not intended to limit design creativity, but provide consistent implementation of monumentation and signage. Design implementation and materials may be substituted from those specified in this Manual, as long as the design consistency of all monumentation is preserved throughout the Plan Area. Any deviation to materials and design intent shall be approved by the City.

The Employment Area Entry Monument has a CMU block internal structure creating the pilaster, which is veneered with a manufactured stone on all sides of the monument. The pilaster is capped by a custom precast concrete cap, sized specifically to the pilaster element. Attached to the pilaster is a metal grid panel with metal accent panel and arched metal panel cap. Refer to General Standards and Reference Items section for additional information. Employment Area Entry Monuments are not required but are strongly encouraged to promote the Plan Area's design aesthetic and distinct identity.

The designs illustrated in this section are not meant to preclude the use of corporate signage/branding for individual tenants.

Design Elements

Refer to General Standards & Reference Items section this chapter for more information

- | | |
|--|--|
| 1. Pilaster | 10. Concrete Masonry Unit Block (CMU) at Monument |
| 2. Pilaster Cap | 11. Stone Veneer Mortar Bed |
| 3. Arched Metal Panel Cap | 12. Internally Illuminated Box attached to CMU Block |
| 4. Metal Grid Panel | 13. Vertical Lettering Panel |
| 5. Perforated Metal Panel | 14. Logo |
| 6. Metal Accent Panel | |
| 7. Metal Tenant Sign Lettering Panel, typ. | |
| 8. Stone Veneer | |
| 9. Landscaping, typ. (not shown) | |

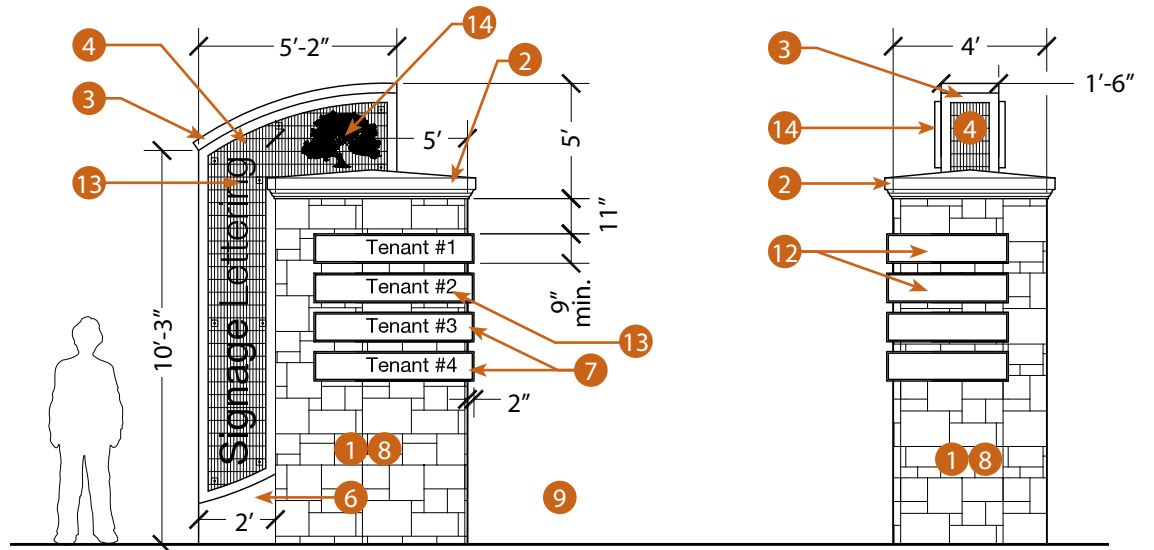

Employment Area Entry Monument Design Concept 1 - Elevation

Not to Scale



Example of Arched Metal Panel Cap



Example of Metal Accent Panel

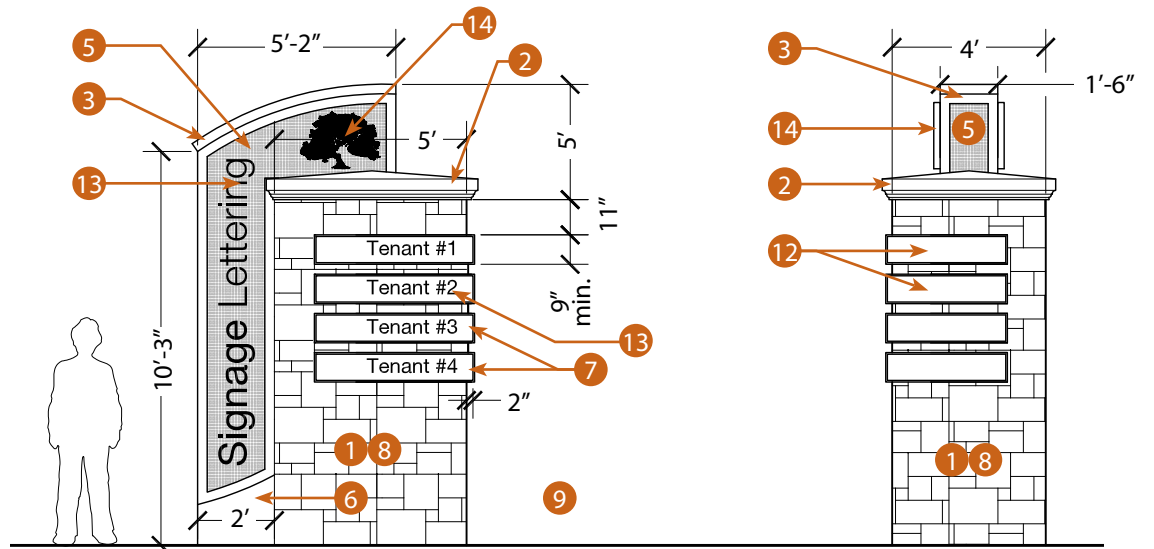

Employment Area Entry Monument Design Concept 2 - Elevation

Not to Scale

CHAPTER 3

ENTRY MONUMENTS, WALLS & FENCES: WALLS & FENCES

D. WALLS & FENCES

1. Walls & Fences Overview

Community walls, pilasters and fences are intended to provide safety, privacy, community theming, identification, and noise reduction along Arterial, Collector, and Primary streets. Walls and fences also delineate property lines and serve as visual and physical separation between land uses. All walls and fences shall utilize the same common elements and be consistent across all land uses within the Plan Area. All community walls, pilasters and fences shall not impede the view of pedestrians and vehicles at road crossings or other intersections and shall comply with all City view triangle and sight distance requirements. Refer to the Walls and Fences Application Plan, this chapter, for wall and fence locations.

A few examples of the various types of Walls & Fences found with the Plan Area



Community Pilaster & Wall



Residential Wood Fence



Split Rail Fence

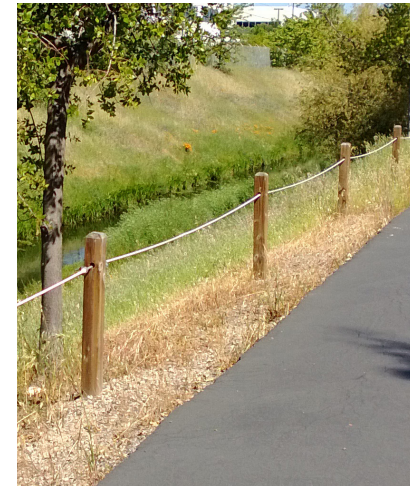

Post & Cable

2. Walls & Fences Plan

The Walls & Fences Plan illustrates the location of fencing types within the Plan Area and provides adjacent land use context. Fencing type and location may be adjusted or determined by the City.

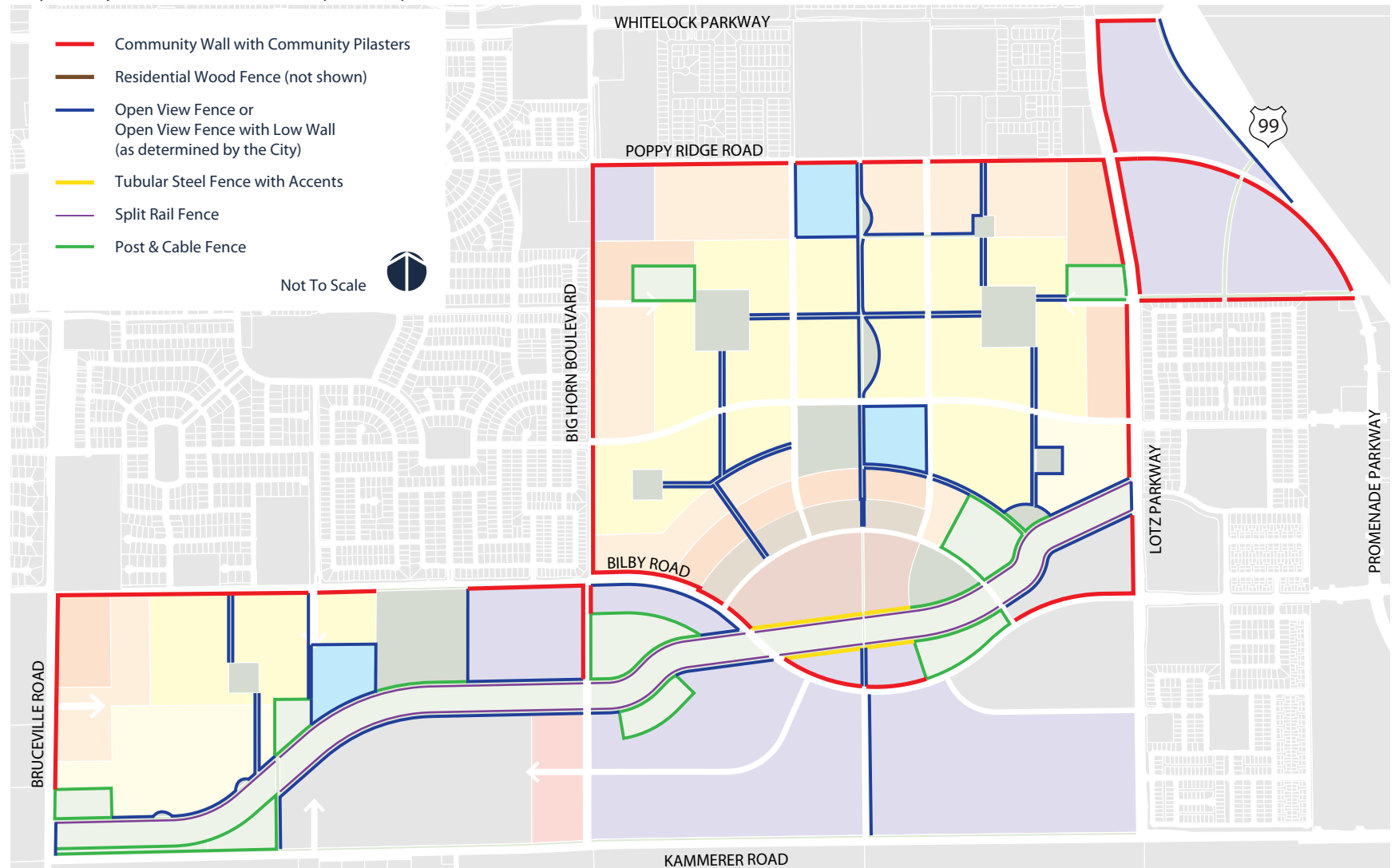

CHAPTER 3

ENTRY MONUMENTS, WALLS & FENCES: WALLS & FENCES

3. Community Pilaster

Community Pilasters shall be located at the beginning and terminus of all Community Walls, at equal spacing based on the overall length of the wall (100' o.c. max) and at a change of wall direction. Community Pilasters shall also be located at the beginning and terminus of Open View Fences or Open View Fences with Low Walls, at equal spacing (100' o.c. max) based on the overall length of the fence and at any change of direction. Community Pilasters shall also occur where an Open View Fence or Open View Fence with Low Wall intersects with each single family residential lot. Community Pilasters shall be centered on the wall or fence and may overlap the property line. All Community Pilasters shall be constructed out of CMUs, veneered with stone on all four sides, and capped with a concrete pilaster cap. Refer to General Standards and Reference Items section this chapter for more information.

Example Design Elements

- A. Community Pilaster
- B. Pilaster Cap
- C. Stone Veneer
- D. Finished Grade

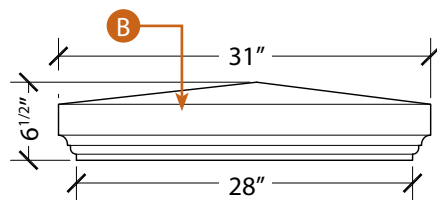

Community Pilaster Cap Enlargement - Not to Scale

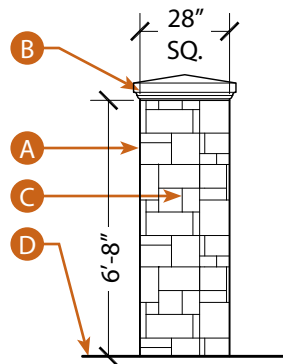

Community Pilaster Elevation - Not to Scale



Community Pilaster Stone Veneer Sample
(refer to General Standards and Reference Items)

4. Low Pilaster

Low pilasters shall be used at the entrances to greenways and where the greenway intersects perpendicularly with any street. Refer to Chapter 5 for more information and for application of pilasters in a greenway or Major Drainage Channel. Low Pilasters may also be used in other locations as determined by the City. Low Pilasters are a decorative element that creates a sense of community, and may be used in conjunction with other walls or as a stand alone decorative pilaster. Low Pilasters shall be constructed of CMUs, veneered with stone on all four sides, and capped with a concrete pilaster cap. Refer to General Standards and Reference Items section this chapter for more information.

Example Design Elements

- a. Low Pilaster
- b. Pilaster Cap
- c. Stone Veneer
- d. Split Rail Fence

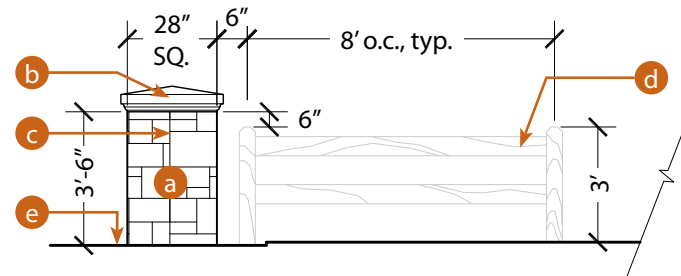

Low Pilaster Elevation - Not to Scale

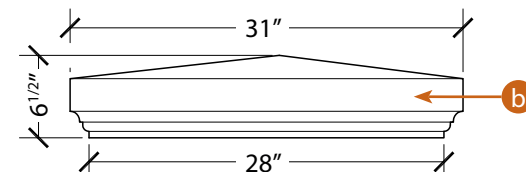

Low Pilaster Cap Enlargement - Not to Scale

5. Community Walls

Community Walls are constructed out of split face CMUs with a custom precast concrete cap and use the “Proto II” wall system by Basalite*. Community Walls shall be 6’ tall throughout all land uses. These walls may be taller with approval from the City and as required by a noise study. If elevation changes are required within the Community Wall, the wall may be stepped. Community Walls shall be located within the Landscape Area of a Landscape Corridor with the back of the wall located on the property line. Community Pilasters shall be located as specified in the Community Pilaster section in this chapter. Additionally, Community Walls shall not impede the view of pedestrians and vehicles at road crossing or other intersections, and shall comply with all City view triangle and sight distance requirements. Community Walls shall only be located between single-family residential land uses abutting medium-density residential, high-density residential, office, light industrial/flex and commercial land uses and the transit corridor. Community Walls shall not be used where single family residential abuts schools, parks, drainage channels and greenways. At all entrances to residential neighborhoods, a Community Wall shall be used. No Residential Wood Fences shall be used in this situation. Refer to Community Wall Locations at Single Family Residential Entry Plan on opposing page for more information. Refer to the Walls & Fences Application Plan in this chapter for the location of Community Walls. Refer to General Standards and Reference Items section in this chapter for more information.

*=Or approved equivalent

Example Design Elements

- A. Proto II Wall
- B. Wall Cap with void for Proto II Wall System’s Tensioning Hardware
- C. Community Pilaster
- D. Finished Grade
- E. Concrete footing per Engineer (not shown)

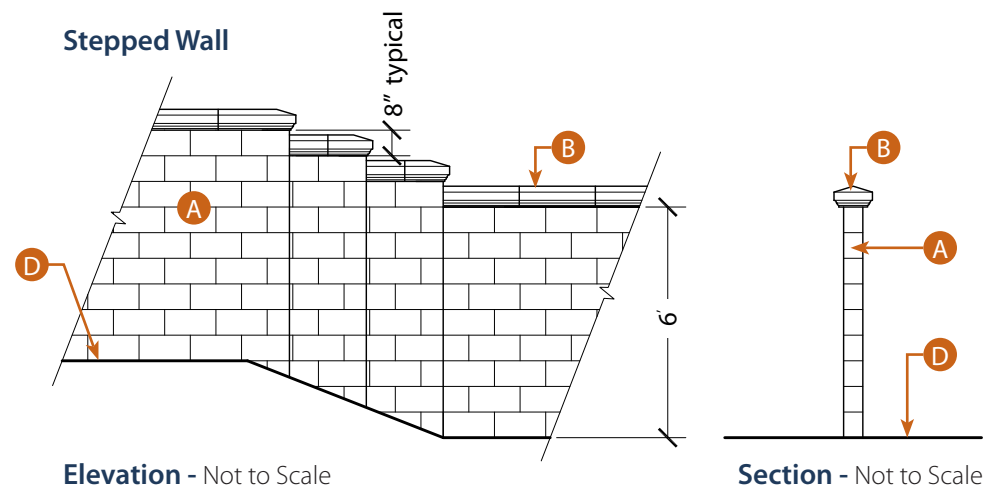
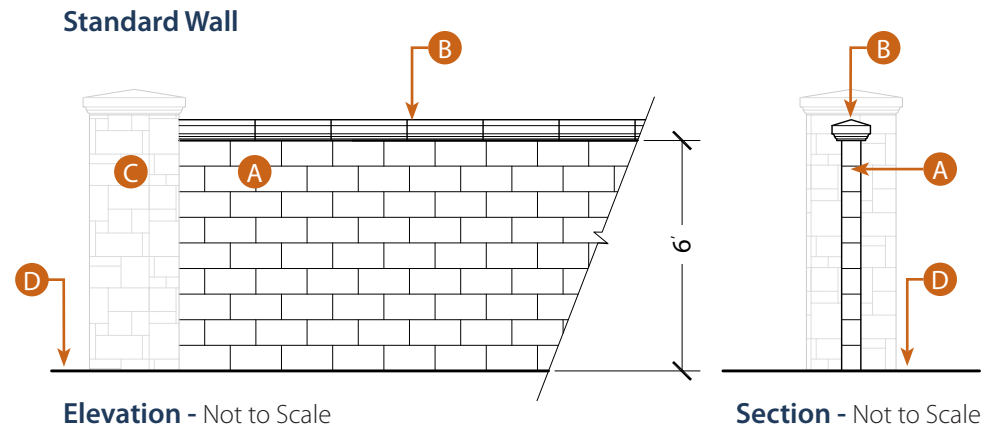

CHAPTER 3

ENTRY MONUMENTS, WALLS & FENCES: WALLS & FENCES



Example of Community Wall



Community Wall Color

(refer to General Standards and Reference Items section)

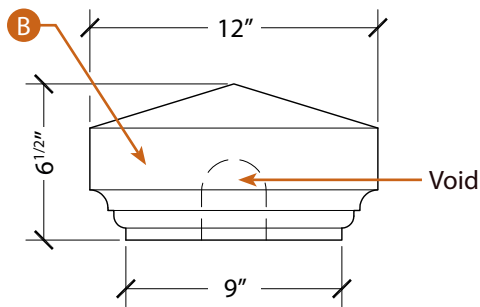

Wall Cap Enlargement - Not to Scale

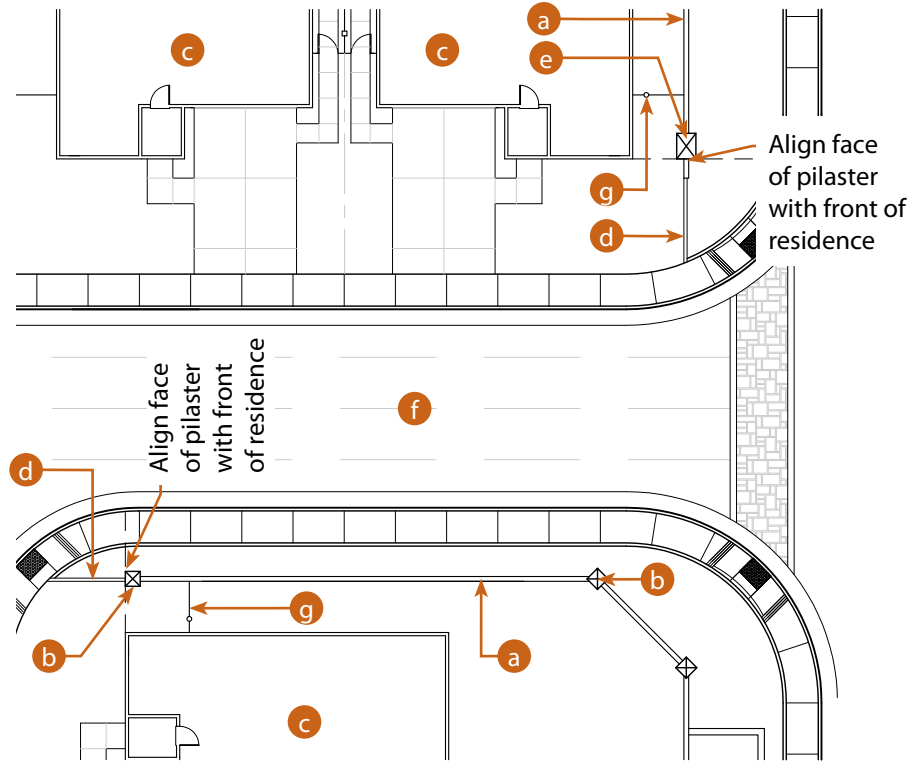

Community Wall Locations at Single-Family Residential Entry Plan

Not to Scale

- a. Community Wall (at neighborhood entry)
- b. Community Pilaster
- c. Single-Family Residence
- d. Edging at Residential Lot
- e. Neighborhood Entry Monument
- f. Local Residential Street (refer to Chapter 2)
- g. Residential Wood Fence

6. Residential Wood Fence

Residential Wood Fences shall be located primarily in front yards as well as side and rear yard property lines at single-family residential lots. Residential Wood Fences may also be used in other residential applications as determined by the City. Residential Wood Fences shall not be used at the entrance to residential neighborhoods (refer to Community Wall Locations at Single Family Residential Entry Plan in this chapter for more information) or adjacent to City and CCSD maintained areas. Refer to the Walls & Fences Application Plan in this chapter for more information regarding Residential Wood Fence Locations. Refer to General Standards and Reference Items section in this chapter for more information.

Example Design Elements

- A. Residential Wood Fence
- B. 1" x 6" cedar overlapped fence boards (sawn texture). Overlap subsequent boards by 1" as shown.
- C. 2" x 6" cedar cap
- D. 2" x 6" cedar rails
- E. 4" x 6" cedar post
- F. Finished Grade
- G. Community Pilaster

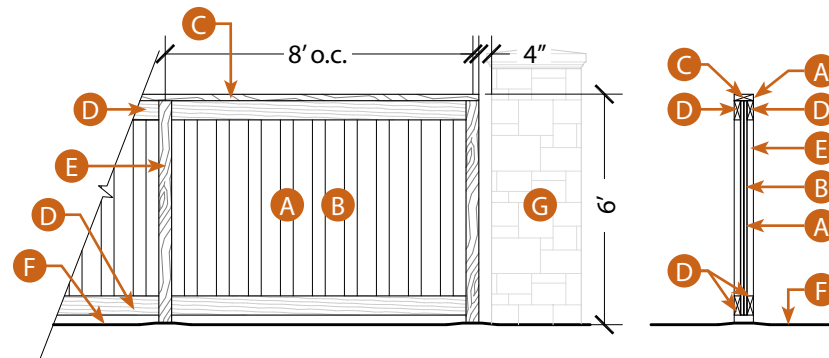

Elevation & Section - Not to Scale

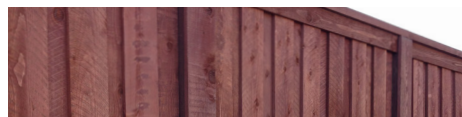

Example of Residential Wood Fence

7. Open View Fence

Open View Fences shall be located in areas where security is required, while still maintaining the view between land uses. Community Pilasters shall be located along Open View Fence as specified in the Community Pilaster section of this chapter. Additionally, Open View Fences shall be located at the property line of the following land uses:

- As allowed by the City and CCSD

Open View Fences may also be used in other locations as determined by the City. Refer to the Walls & Fences Application Plan in this chapter for the location of Open View Fences. Refer to General Standards and Reference Items section in this chapter for more information.

Example Design Elements

- a. Open View Fence
- b. Community Pilaster
- c. Finished Grade

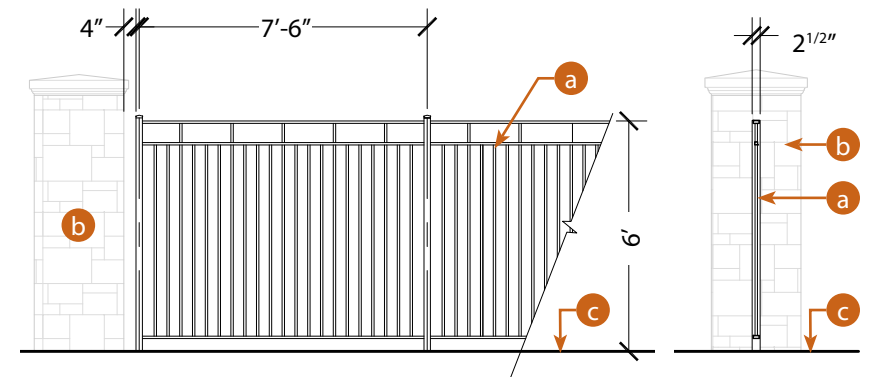

Elevation & Section - Not to Scale

CHAPTER 3

ENTRY MONUMENTS, WALLS & FENCES: WALLS & FENCES

8. Open View Fence with Low Wall

Open View Fences with Low Walls shall be located in areas where security is required, while still maintaining the view between land uses. Community Pilasters shall be located along Open View Fence with Low Wall as specified in the Community Pilaster section of this chapter. Additionally, Open View Fences with Walls shall be located at the property line of the following land uses:

- CCSD maintained areas adjacent to residential (low, medium, and high density) and office land uses

Open View Fences with Low Walls may also be used in other locations as determined by the City. Refer to the Walls & Fences Application Plan in this chapter for the location of Open View Fences with Low Walls. Refer to General Standards and Reference Items section in this chapter for more information.

Example Design Elements

- A. Open View Fence with Low Wall C. Finished Grade
B. Community Pilaster

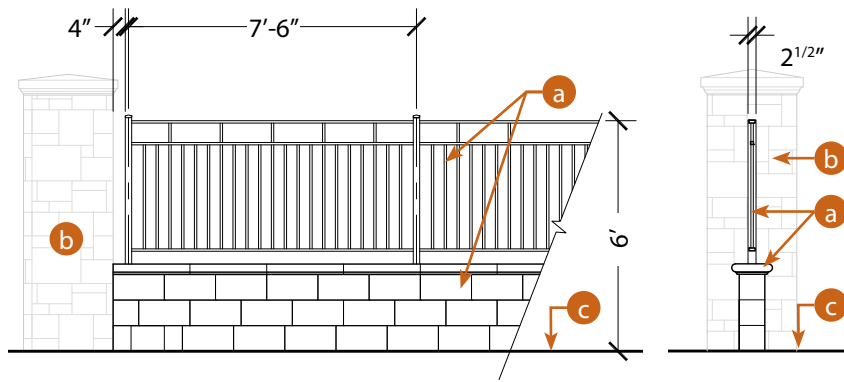

Elevation & Section - Not to Scale

9. Split Rail Fence

Split rail fences shall be located adjacent to the Major Drainage Channel Trail Landscaping, entrances to Greenways and Major Drainage Channels, as well as other locations as determined by the City. Refer to Materials Overview section in this chapter for more information.



Example of Concrete Split Rail Fencing

10. Post and Cable Fence

Post and Cable Fences shall be located around all sides of all drainage facilities located within the Plan Area. This shall include Drainage Basins, Joint Use Park/Detention Facilities, as well as locations where these drainage facilities abut the Major Drainage Channel. Refer to the Walls & Fences Application Plan for the location of Post and Cable Fence. The Post and Cable Fence may also be used in other locations as determined by the City of Elk Grove. Refer to Materials Overview section in this chapter for more information.

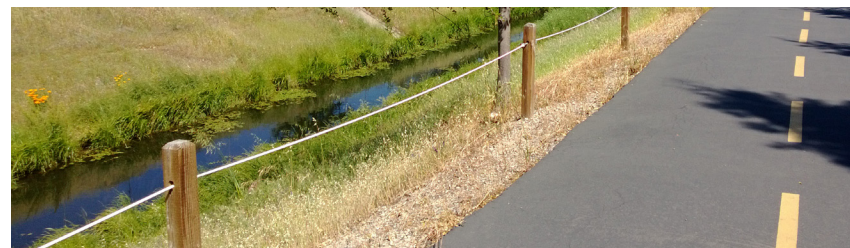

Example of Post and Cable Fencing

11. Other Walls & Fences

a. Tubular Steel Fence with Accents

Tubular Steel Fence with Accents shall be located in the mixed use village center land use and, as applicable, within mixed use residential land use. The Tubular Steel Fence with Accents shall be used in the village center area where paving in the form of gathering spaces and plazas about the Major Drainage Channel. Additionally, the Tubular Steel Fence with Accents may be used in Greenways, Drainage Corridors and Drainage Facilities, as determined by the City and CCSD. Lastly, Tubular Steel Fence with Accents may be used to enclose outdoor eating areas connected to restaurants, coffee bars or other eateries.

Artistic fence embellishments, similar to laser-cut filigrees, resembling wildlife and plants that inhabit the Plan Area (Hérons, Swansons Hawk, Garter Snake, Juncus, Oaks, etc.) are recommended in Greenways, Drainage Corridors and Drainage Facilities. Design of artistic features shall be approved by the City and CCSD. Refer to the Walls & Fences Application Plan for the location of Tubular Steel Fence with Accents. Tubular Steel Fence with Accents may be used in other locations a determined by the City. Refer to General Standards and Reference Items section in this chapter for more information.

Example Design Elements

- A. Tubular Steel Fence with Accents
- B. Finished Grade
- C. Artistic Fence Embellishments (not shown)

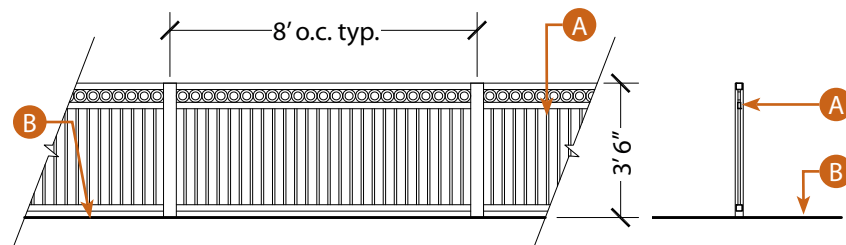

Elevation & Section - Not to Scale

b. Courtyard Wall

Courtyard Walls may be located in residential land uses where a private outdoor living area (as defined in the SPA) is allowed. Courtyard walls may also be located in plaza areas within office and light industrial/flex land uses and other landed uses as allowed by the City. These walls shall be constructed out of CMUs, veneered with stucco on all sides (as determined by the City), and capped with a precast concrete wall cap. Refer to General Standards and Reference Items section in this chapter for more information.

Example Design Elements

- a. Courtyard Wall
- b. Standard CMU with Stucco Finish
- c. Wall Cap
- d. Finished Grade

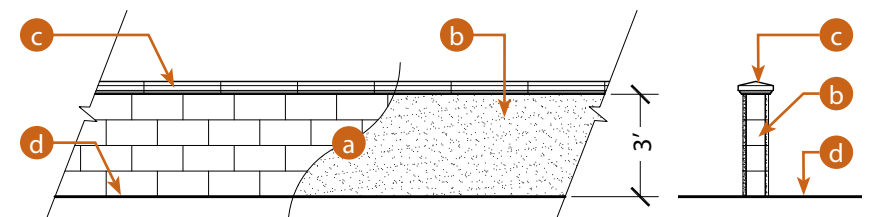

Wall Elevation & Section - Not to Scale

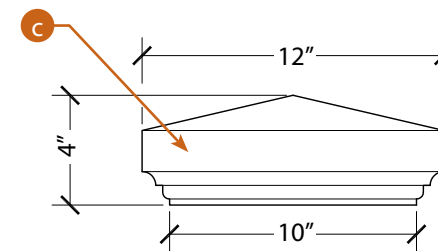

Wall Cap Enlargement - Not to Scale

CHAPTER 3

ENTRY MONUMENTS, WALLS & FENCES: WALLS & FENCES

c. Stone Veneer Courtyard Wall

Stone Veneer Courtyard Walls may be located in residential land uses where a private outdoor living area (as defined in the SPA) is allowed. Stone Veneer Courtyard Walls may also be located in plaza areas within office and light industrial/flex land uses and other land uses, as allowed by the City. Stone Veneer Courtyard Walls shall be constructed out of CMUs, veneered with stone on all sides (as determined by the City), and capped with a precast concrete wall cap. Refer to General Standards and Reference Items section in this chapter for more information.

Example Design Elements

- A. Courtyard Wall
- B. Stone Veneer
- C. Wall Cap
- D. Finished Grade

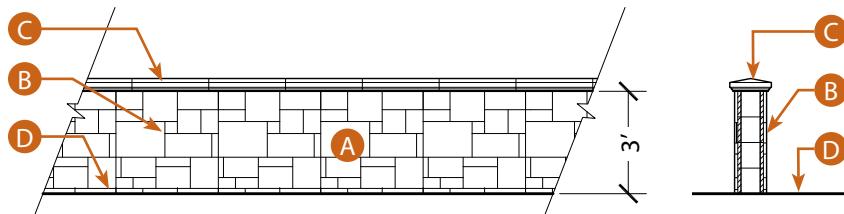

Stone Veneer Courtyard Wall Elevation & Section - Not to Scale

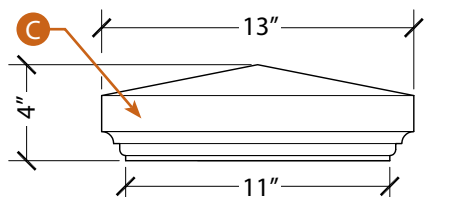

Stone Veneer Courtyard Wall
Cap Enlargement - Not to Scale

d. Seatwall

Seatwalls may be located in medium and high density residential, mixed use residential, mixed use village center land uses, as well as in office, light industrial/flex and commercial land uses. Seatwalls may also be used in other locations as determined by the City. Seatwalls are a decorative element allowing pedestrians to sit and gather within specific areas of the Plan Area. Seatwalls may be used in conjunction with Low Pilasters. Seatwalls shall be constructed out of CMUs, veneered with stucco on all sides (as determined by the City), and capped with a precast concrete wall cap. Seatwall caps shall be flat without any peak to allow pedestrians to sit on the cap. Refer to General Standards and Reference Items section in this chapter for more information.

Example Design Elements

- a. Seatwall
- b. Standard Smooth Face CMU with Stucco Finish
- c. Wall Cap
- d. Finished Grade

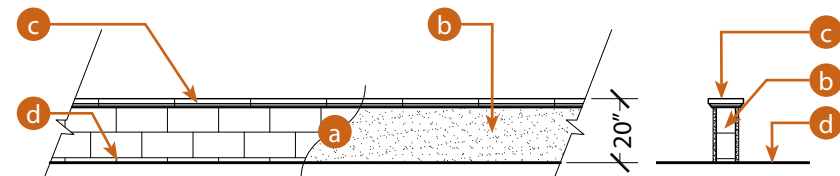

Seatwall Elevation & Section - Not to Scale

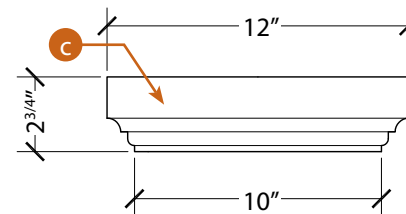

Seatwall Cap
Enlargement -
Not to Scale

e. Stone Veneer Seatwall

Stone Veneer Seatwalls may be located in medium and high density residential, mixed use residential, mixed use village center land uses, as well as in office, light industrial/flex and commercial land uses. Stone Veneer Seatwalls may also be used in other locations as determined by the City. Stone Veneer Seatwalls are a decorative element allowing pedestrians to sit and gather within specific areas of the Plan Area. Stone Veneer Seatwalls may be used in conjunction with Low Pilasters. Stone Veneer Seatwalls shall be constructed out of CMUs, veneered with stone on all sides (as determined by the City), and capped with a precast concrete wall cap. Seatwall caps shall be flat without any peak to allow pedestrians to sit on the cap. Refer to General Standards and Reference Items section in this chapter for more information.

Example Design Elements

- A. Seatwall
- B. Stone Veneer
- C. Wall Cap
- D. Finished Grade

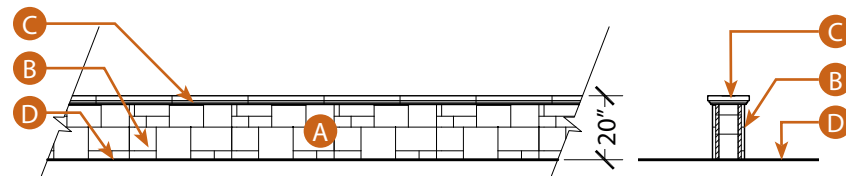

Stone Veneer Seatwall Elevation & Section - Not to Scale

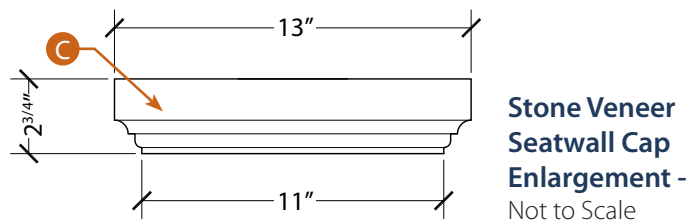

Stone Veneer Seatwall Cap Enlargement - Not to Scale

CHAPTER 4

STREETSCAPE MATERIALS, SITE FURNISHINGS & PROJECT AMENITIES

SOUTHEAST POLICY AREA

SPECIAL PLANNING AREA

LANDSCAPE PLANNING PROTOTYPE MANUAL

CHAPTER 4

STREETSCAPE MATERIALS, SITE FURNISHINGS & PROJECT AMENITIES

A. CHAPTER OVERVIEW

Streetscape materials, site furnishings and project amenities create a pedestrian scaled community, while invoking a sense of place and overall identity for the Plan Area. These elements convey a contemporary feeling and invite people to experience their environment and community. A consistent palette of streetscape materials and furnishings are specified throughout the Plan Area, including, but not limited to, benches, picnic tables, trash receptacles, drinking fountains, bicycle racks, tree grates, bollards, lighted bollards, primary streetlights, and pedestrian scaled street lights. Additionally, various community materials as well as pedestrian bridges are specified in this chapter.

Note: The images in this chapter show design intent and are for reference purposes only. Images throughout this chapter may not reflect the actual model number or colors specified. Specific manufactures/models may be substituted with approved equivalents.

CHAPTER 4

STREETSCAPE MATERIALS, STREET FURNISHINGS & PROJECT AMENITIES STANDARDS & MATERIALS

B. STANDARDS & MATERIALS

Streetscape materials, site furnishings, and project amenities located within all areas of Plan Area are included in this chapter. Streetscape materials, site furnishings, and project amenities located within the Mixed Use Village Center shall be determined by the City and the master developer of the Mixed Use Village Center and approved by the City.

1. Bench:

Manufacturer: Urbanscape/Wabash Valley*
Model Number: Camden CA11191 | 6' Bench with back, with arms | Horizontal Slat | Inground Mount
Finish: Powder Coated Textured Black in CCSD maintained Areas.
Other colors may be proposed in non-CCSD maintained areas
Representative: David F. O'Keefe Company
699 Hilldale Ave. | Berkeley, CA 94708
Contact: (925) 984-2075



2. Picnic Table - 6' Length:

Manufacturer: Outdoor Creations*
Model Number: 101FSSK | 6' Concrete Table
Finish: Padre Brown (Davis Color) in CCSD maintained Areas.
Other colors may be proposed in non-CCSD maintained areas
Representative: Outdoor Creations
2270 Barney Road | Anderson, CA 96007
Contact: (530) 365-6106



3. Picnic Table - 8' Length:

Manufacturer: Outdoor Creations*
Model Number: 100FSSK | 8' Concrete Table (must be ADA accessible)
Finish: Padre Brown (Davis Color) in CCSD maintained Areas.
Other colors may be proposed in non-CCSD maintained areas
Representative: Outdoor Creations
2270 Barney Road | Anderson, CA 96007
Contact: (530) 365-6106

* = Or approved equivalent

4. Trash Receptacle:

Manufacturer: Outdoor Creations*
 Model Number: 500 | 35 gallon Concrete Round Waste Receptacle
 Finish: Padre Brown (Davis Color) with Cast City of Elk Grove
 Logo in CCSD maintained Areas.
 Other colors may be proposed in non-CCSD maintained areas
 Representative: Outdoor Creations
 2270 Barney Road | Anderson, CA 96007
 Contact: (530) 365-6106



5. Recycle Receptacle:

Manufacturer: Outdoor Creations*
 Model Number: 500 | 35 gallon Concrete Round Waste Receptacle
 Padre Brown (Davis Color) with Cast City of Elk Grove
 Logo & Green Recycle Logo in CCSD maintained Areas.
 Other colors may be proposed in non-CCSD maintained areas.
 Representative: Outdoor Creations
 2270 Barney Road | Anderson, CA 96007
 Contact: (530) 365-6106

6. Bike Rack:

Manufacturer: DuMor Site Furnishings*
 Model Number: Series 83-00 Loop Biker Rack Each
 Inground Mount
 Finish: Powder Coated Black
 Representative: Ross Recreation Equipment Company, Inc.
 110 Brush Creek Road | Santa Rosa, CA 95404
 Contact: (855) 892-3240



* = Or approved equivalent

CHAPTER 4

STREETSCAPE MATERIALS, STREET FURNISHINGS & PROJECT AMENITIES STANDARDS & MATERIALS

7. Drinking Fountain:

Manufacturer: Most Dependable Fountains*
Model Number: 440SM | Drinking Fountain
Finish: Powder Coated Black
Representative: Husbands & Associates
120 Spring Street, Suite D | Pleasanton, CA 94566
Contact: (925) 426-5001



8. Tree Grate:

Manufacturer: Ironsmith*
Model Number: Del Sol Series Square Tree Grate | Size: 6' square min.
or as required
Finish: Powder Coated Black
Representative: Hilton Construction Products
440 Mira Street | Reno, NV 89521
Contact: (775) 843-0330

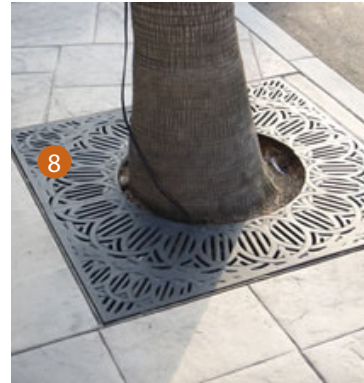

9. Dog Litter Bag Dispenser:

Manufacturer: Dogipot*
Model Number: 1005-2 | Poly Dogipot DogValet system
Finish: Forest Green
Representative: Yuckos
3027 Charmbrook Lane | Maryland Heights, MO 63043
Contact: (314) 770-1500



* = Or approved equivalent

10. Tree Root Barrier:

Manufacturer: **Vespro, Inc.***
 Representative: **Vespro, Inc.**
 3255 Kerner Blvd., Suite 6 | San Rafael, CA 94901
 Contact: (800) 554-0914

Refer to Tree Root Barrier detail for more information.

11. Redwood Headerboard:

Refer to City of Elk Grove Standard Detail L-27 for more information.

12. Concrete Mowstrip:

Refer to City of Elk Grove Standard Detail L-24 for more information.

13. Stationary Bollard:

Manufacturer: **FairWeather Site Furnishings***
 Model Number: **48" Bollard | B-4-5B2 (Removable Mounting and Embedded Mounting)**
 Finish: **Powder Coated Mineral Bronze with corrosion resistant undercoat**
 Representative: **Fair Weather Site Furnishings**
 1540 Leader International Drive | Port Orchard, WA 98367
 Contact: (800) 323-1798

14. Knock-Down Bollard:

Refer to City of Elk Grove Standard Detail L-21 for more information.

15. Lighted Bollard:

Manufacturer: **Halophane***
 Model Number: **BOL/H46/10/L-CA/DB Hamilton Series Cast Aluminum Lighted Bollard with High Pressure Sodium Light Source and Lamp Deflectors as required by City.**
 Finish: **Cast Aluminum Dark Bronze**
 Representative: **Halophane**
 4565 Fremont's Loop | Rescue, CA 95672
 Contact: (530) 676-7071

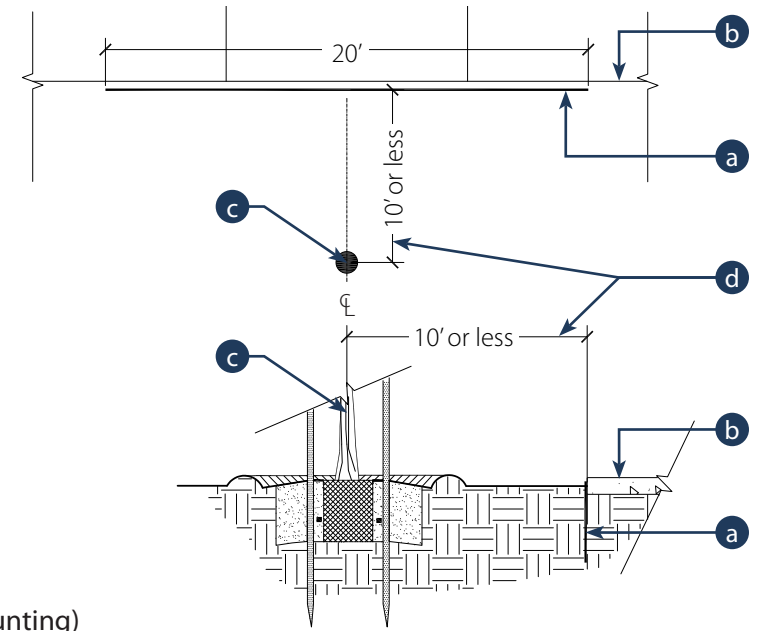

10 Tree Root Barrier Detail - Not to Scale

- a. Root Barrier
- b. Sidewalk/hardscape or curb.
- c. Tree
- d. Install linear root barrier adjacent to hardscape where tree planting occurs within 10' of hardscape

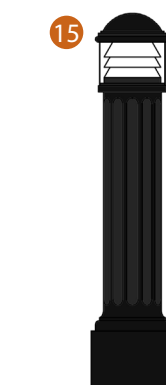

* = Or approved equivalent

CHAPTER 4

STREETSCAPE MATERIALS, STREET FURNISHINGS & PROJECT AMENITIES STANDARDS & MATERIALS

16. Street Lighting

There are two sizes of street lights available for use within the Plan Area. These include the 14' high pedestrian scaled light and the larger 28' primary streetlight. Pedestrian scaled lighting shall be located at sections of the collector main street, and various collector and local streets, as well as the interior project site of various land uses. Exact locations of pedestrian scaled lighting shall be determined by an Electrical Engineer in review of the City of Elk Grove Public Works Improvement Standards, Section 5 - Street Lighting Design (latest edition); as well as all other applicable City requirements, and as approved by the City. Primary streetlights shall be located on Kammerer Road, all Arterial streets, and various collector and local streets, as well as the interior project site of various land uses. Exact locations of primary streetlights shall be determined by an Electrical Engineer in review of the City of Elk Grove Public Works Improvement Standards, Section 5 - Street Lighting Design (latest edition); as well as all other applicable City requirements, and as approved by the City. All pedestrian scaled lights and primary streetlights within the Plan Area shall use LED fixtures.



Two manufacturers are specified for both the Pedestrian Scaled Lighting and Primary Streetlight within the Plan Area. The property owner and lighting designer shall determine the manufacturer appropriate for their project type and as approved by the City of Elk Grove. Each project site within a particular land use shall have one consistent manufacturer across the entire site. Also, each streetscape shall have one consistent manufacturer across the entire streetscape.

16a. Pedestrian Scaled Lighting

Manufacturer: **Halophane**
 Luminaire: **CHA 14 S4J 12 PO7 ABG BZ**
 Pole: **GVD 40 4K AS M Z 3 N N U**
 Finish: **Bronze**
 Representative: **Halophane**
4565 Fremont’s Loop
Rescue, CA 95672
Contact: (530) 676-7071

OR

Manufacturer: **Phillip Hadco**
 Type: **SL-34**
 Luminaire: **S56-55W48LED4K-R-GL-LE3-120-SFX-TN3-FN1-BRTX**
 Pole: **N99-B360**
 Finish: **Bronze**
 Representative: **Associated Lighting Reps.**
7300 Folsom Blvd
Sacramento, CA 95826
Contact: (916) 383-4545

16b. Primary Streetlight (Single Arm)

Manufacturer: **Halophane**
 Luminaire: **ESL 110 4K AS-S Z 4H**
 Pole: **SR28/183 HOLU721A**
 Finial: **SRFBZH**
 Crossarm: **TLP52/1U 712A**
 Fitter: **WLLF-200-CA-BZ**
 Finish: **Bronze**
 Representative: **Halophane**
4565 Fremont’s Loop
Rescue, CA 95672
Contact: (530) 676-7071

OR

Manufacturer: **Phillip Hadco**
 Type: **Type SL-31**
 Luminaire: **RN30-55W32LED4K-R-LE3R-GL-120-SMA-BRTX**
 Pole: **N40094-B33-Y1**
 Finish: **Bronze**
 Representative: **Associated Lighting Reps.**
7300 Folsom Blvd.
Sacramento, CA 95826
Contact: (916) 383-4545

16c. Primary Streetlight (Double Arm)

Manufacturer: **Halophane**
 Luminaire: **ESL 110 4K AS-S Z 4H**
 Pole: **SR28/183 HOLU721A**
 Finial: **SRFBZH**
 Crossarm: **TLP52/1U 712 TLP52/2U 713A**
 Fitter: **WLLF-200-CA-BZ**
 Finish: **Bronze**
 Representative: **Halophane**
4565 Fremont’s Loop
Rescue, CA 95672
Contact: (530) 676-7071

OR

Manufacturer: **Phillip Hadco**
 Type: **Type SL-30**
 Luminaire: **(2)RN30-55W32LED4K-R-LE3R-GL-120-SMA-BRTX**
 Pole: **N40094-B33-Y2**
 Finish: **Bronze**
 Representative: **Associated Lighting Reps.**
7300 Folsom Blvd.
Sacramento, CA 95826
Contact: (916) 383-4545

17. Informational Kiosk

Informational Kiosks are located throughout the Plan Area within greenways, landscape drainage corridors and drainage facilities. These kiosks provide information regarding man-made and natural features in the areas in which the sign is located. These kiosks help the user better understand the specific elements that exist within the greenway and drainage areas, and provide local and regional context to these elements.

Informational Kiosks can be either an interpretive sign or double-sided kiosk with benches. Use of an interpretive sign or double-sided kiosk with benches shall be determined by the City and CCSD. The content contained on each informational kiosk shall be specific to the area in which the kiosk will be located. Therefore, the content contained on each informational kiosk shall be determined and approved by the City and CCSD prior to installation of any informational kiosks.

a. Interpretive Sign

Manufacturer: **KVO Industries, Inc.***

Model Number: **36" x 24" High Pressure Laminate Sign with
36" x 24" Slimline Low Profile, Exhibit Base
Double Leg Pedestal, In Ground Mount**

Finish: **Powder Coated Spruce Wrinkle Semi-Gloss**

Representative: **KVO Industries, Inc.**

1825 Empire Industrial Court | Santa Rosa, CA 95403

Contact: (707) 573-6868

- One spare interpretive sign board shall be provided to the City Operations & Maintenance Division.

b. Interpretive Double-Sided Kiosk with Benches

Manufacturer: **Poligon***

Model Number: **CCSD shall select model during design process.**

Representative: **Poligon (Porter Corporation)**

14240 North 136th Avenue | Holland, MI 49424

Contact: (616) 399-1963

18. Directional Wayfinding Signage

Directional Wayfinding Signage provides thematic on-site directional information to points of interest and land uses. Directional wayfinding signage is required within the Plan Area. The City shall determine all locations for wayfinding signage. All wayfinding signage shall comply with the requirements set forth by the City. Refer to the City for more information.

* = Or approved equivalent

19. Pedestrian Bridge

There are two (2) pedestrian steel truss bridges proposed within the Plan Area. These pedestrian bridges provide access across both sides of the Major Drainage Channel. All pedestrian bridges shall be the same manufacturer, model and finish. Each pedestrian bridge shall be the same width, but may vary in length depending on the span required to cross the Major Drainage Channel at each location. Refer to the Southeast Policy Area Special Planning Area document, Chapter 2 Land Plan, for specific locations of pedestrian bridges.

Manufacturer: **Contech Engineered Solutions***

Model Number: **Connector Pedestrian Truss | Cambered Design**

Finish: **Weathered Steel or Painted Steel | Color TBD**
(Finish and color of all bridges to be determined by the City)

Representative: **Contech Engineered Solutions**

5 Sierra Gate Plaza, Suite 390 | Roseville, CA 95678

Contact: (562) 264-0700



*=Or approved equivalent

CHAPTER 5

GREENWAYS, DRAINAGE CORRIDORS &
FACILITIES

**SOUTHEAST
POLICY AREA**

SPECIAL PLANNING AREA

LANDSCAPE PLANNING PROTOTYPE MANUAL

CHAPTER 5

GREENWAYS, DRAINAGE CORRIDORS & FACILITIES

A. CHAPTER OVERVIEW

Greenways, landscape drainage corridors and drainage facilities create a continuous pedestrian landscape corridor system throughout the Plan Area, providing an alternative to traditional pedestrian access routes such as street sidewalks. This creates a unique and distinctive element within the community. These areas include greenways, as well as drainage areas such as the Major Drainage Channel (Shed C Channel), Drainage Basins and Joint Use Park/Drainage Facilities. Greenways, as well as landscape drainage corridors and facilities, are designed to be an integral part of the community, not independent elements within it. These areas provide permanent open space, trail systems and extensive landscape corridors and pedestrian connections. Together, these elements create communities that are compact in scale and easily walkable, linked by an extensive network of multi-use trails. Specifically within the drainage areas, a design emphasis has been placed on the idea of a safe and usable pedestrian environment, which accentuates nature and the surrounding environment.

CHAPTER 5

GREENWAYS, DRAINAGE CORRIDORS & FACILITIES

CHAPTER OVERVIEW

As all landscape areas within greenways and drainage areas shall be considered public improvements, the trail system design, landscape amenities, site furnishings and materials within all greenways and drainage corridor and facilities shall comply with all City requirements and be approved by both the Consumnes Community Services District (CCSD) and the City. Additionally, all plantings within any greenway or drainage corridor and facilities must be approved by the CCSD and the City. Traditional recreation parks are not included in this Manual, as these areas have very specific requirements as set forth by the CCSD. The user shall refer to the CCSD for all recreation park design requirements.



B. GENERAL STANDARDS & REFERENCE ITEMS

1. General Landscaping Standards

The following is a list of general landscaping requirements for all Greenways, Drainage Corridors and Drainage Facilities:

1. All Greenways shall be 40' wide minimum, unless a variance to this requirement is allowed by the City.
2. Either low pilasters with split rail fence, and/or park bollard shall be located at the pathway entrance to all greenways, drainage corridors and drainage facilities connecting from a perpendicular street as determined by the City.
3. Colored asphalt enhanced paving crosswalks shall be located at specific street crossings with pathway connections, as determined by the City.
4. As determined by the City and CCSD, pathways shall be constructed out of:
 - Asphalt paving with a 2' wide decomposed granite shoulder on both sides (2) of the pathway. The shoulder shall be edged with a redwood headerboard.
 - Concrete paving with a 2' wide decomposed granite shoulder on one side (1) of the pathway. Depending on the site's grading, the shoulder shall be edged with either City of Elk Grove Type 3 Curb or concrete mowstrip.
 - Concrete paving (for minor short connections only)

All Greenway, Drainage Corridors and Drainage Facilities pathway, shoulder, and shoulder edging shall be reviewed and approved by the City and CCSD.
5. Site furniture and amenities shall include, but not limited to, benches, trash receptacles, drinking fountains, bike racks, dog waste stations, post & cable fences, split rail fences, and informational kiosks.
6. Pedestrian scale lighted bollards with lamp deflectors shall be located throughout Greenways, Drainage Corridors and Facilities. Lighted bollards shall be placed along the pathway, and situated to prevent light from shining directly into adjacent land uses. Spacing and foot-candle requirements shall be determined by the Electrical Engineer and approved by the City.
7. Where open view fencing or open view fencing with low wall separates the greenway from any other land use, community pilasters shall be located at the beginning and terminus of open view fences, and any change of fence direction. Community pilasters at open view fences shall occur +/- every 100', or closest proximity thereof. Community pilasters at open view fences shall also occur where a open view fence intersects with each single family residential lot.
8. Where open view fencing or open view fencing with low wall separates the landscape corridor abutting the Greenways, Drainage Corridor and Drainage Facilities from any other land use, community pilasters shall be located at the beginning and terminus of open view fences, and any change of fence direction. Pilasters at open view fences shall occur +/- every 100', or closest proximity thereof. Pilasters at open view fences shall also occur where a open view fence intersects each land use and separate lot within the land use.
9. Post and cable fence shall be located at each property line adjacent to Drainage Corridors and Drainage Facilities.
10. Greenways shall be separated by a community wall with community pilasters or open view fence with community pilaster as determined by the City.

CHAPTER 5

GREENWAYS, DRAINAGE CORRIDORS & FACILITIES GENERAL STANDARDS & REFERENCE ITEMS

11. Informational Kiosks are located throughout the Plan Area within greenways, landscape drainage corridors and drainage facilities. Informational Kiosk type and content shall be determined and approved by the City and CCSD. (Refer to Chapter 4)
12. Landscaping grading and slopes shall not exceed 5:1 for turf areas and 4:1 for planting areas (except at Detention Basin and Major Drainage Channel Side Slopes). If Landscaping grading or slopes exceed these ratios, a split face keystone retaining wall shall be required. All retaining walls shall be reviewed and approved by the City and CCSD. Steeper grades are permitted within the Detention Basin and Major Drainage Channel Side Slopes, however maximum slopes must be reviewed and approved by the City and CCSD.
13. The planting design shall be subject to the most current City of Elk Grove Model Water Efficient Landscape Ordinance (MWELO). Turf in Greenways, Drainage Corridors and Drainage Facilities is permitted as long as the requirements of the MWELO are met.
14. Plantings in Greenways shall include shade trees in informal plantings, as well as turf, groundcover and evergreen shrub massing along property lines. Additionally, vines shall be located at 10'-0" on center spacing along any community walls.
15. Planting outside of drainage areas shall include shade trees in informal plantings, as well as turf, groundcover and evergreen shrub massings throughout the landscape area and along property lines. The plant palette outside the drainage areas shall be consistent with the landscape concept of the community and as required in the General Landscape Plant Palette. The drainage areas shall be planted with acceptable trees, groundcover and grasses as required in the Drainage Areas Plant Palette.
16. Grasses and groundcovers within the Major Drainage Channel, Drainage Basin and Detention Facilities shall be a seed mix, installed by hydroseed. Seed quantity, including pounds of seed per acre, and the exact hydroseed method of installation, shall be determined by the City other required government agencies.
17. All grasses, including native grasses, outside of the drainage areas shall be either 1 gallon containers, plugs, hydroseed or sod to be determined by the City.
18. When a particular size plant is specified across large sections of greenway/drainage corridor and facilities (i.e. medium shrub), the landscape architect shall use alternating groupings of plants from that specific section of the General Landscape Plant Palette (refer to Chapter 6) to achieve a planting design that has different genus and species along the entire streetscape. This shall be done to prevent a monolithic plant palette extending along the entire greenway/drainage corridor and facilities.
19. Secondary or accent trees located within the streetscape landscape area (not medians) or greenways shall occur in informal groupings of three or five trees of the same species, planted between the sidewalk and adjacent land use property line. Mixed massings of flowering trees and evergreen species are encouraged.
20. Secondary or accent trees shall be a combination of deciduous and evergreen trees for purposes of screening and creating seasonal change. A minimum of 30% of the street trees and secondary or accent trees shall be evergreen species.
21. All trees shall be 15 gallon minimum, one-third of all trees shall be 24" box or larger.
22. All shrubs shall be 5 gallon minimum. Plants that are not commercially available in a 5 gallon size, may be substituted for a 1 gallon size.

23. All groundcover shall be a minimum of 1 gallon. Groundcovers that are not commercially available in a 1 gallon size, may be substituted for flats of up to 64 plants. Root cuttings from plants shall not be located greater than 12 inches on center spacing. Containerized 1 gallon groundcover plants shall not be located greater than 3' on center spacing.
24. A 3" layer of walk-on type bark mulch shall be located in all planter areas around trees, shrubs and groundcover within all greenways, drainage corridors and drainage facilities. Bark mulch shall not be used on any drainage side slopes and drainage low-flow areas.
25. All trees planted within 10 feet of a street, sidewalk, paved trail, walkway or plaza element shall be separated by a root barrier to prevent damage to public improvements. This root barrier must be installed at time of planting of the tree. (Refer to Chapter 4)
26. A minimum distance of 15' is required between the center of a tree and all light standards.
27. All shrubs and trees shall comply with the City's site visibility requirements and the view triangle requirements.
28. Plantings of shrub massings shall be in large groupings, layered to provide visual interest. Variety in height is encouraged. Multiple rows of layered plantings are encouraged where space is adequate.
29. Parks located within the Plan Area are not included in this manual, as these areas have very specific requirements as set forth by the CCSD. The user shall refer to the CCSD for all recreation park design requirements. For more information regarding all park requirements within the Plan Area, please contact the Cosumnes Community Services District, Parks and Recreation Department at (916) 405-5309.

2. Reference Items

Planting and Landscape

Refer to the following chapters of this Manual, as required.

1. Primary Street Tree (refer to Chapter 6)
2. Primary Greenway Trees (refer to Chapter 6)
3. Primary Drainage Area Trees (Refer to Chapter 6)
4. Secondary Greenway Trees (refer to Chapter 6)
5. Accent Tree (refer to Chapter 6)
6. Accent Drainage Areas Trees (refer to Chapter 6)
7. Large Shrub (refer to Chapter 6)
8. Medium Shrub (refer to Chapter 6)
9. Small Shrub (refer to Chapter 6)
10. Small Shrubs & Groundcover (refer to Chapter 6)
11. Sodded Turf (refer to Chapter 6)
12. Vine (refer to Chapter 6)
13. Native Grass Seed Mix (refer to Chapter 6)
14. Drainage Area Side Slopes Seed Mix (refer to Chapter 6)
15. Drainage Area Low Flow Bottom Seed Mix (refer to Chapter 6)
16. Landscaping (private landscaping designed by to the City's satisfaction and maintained by the landowner)

Hardscape and Amenities

Refer to the following chapters of this Manual, as required:

1. Street (refer to Chapter 2)
2. Pathway (use of Concrete or Asphalt to be determined by the City and CCSD). If concrete, score joints on-center spacing equal to width of sidewalk. Expansion joints spacing shall be as required per the Geotechnical Report. If no Geotechnical Report exists, expansion joints shall be every fourth score joint minimum. (Refer to geotechnical report for the Southeast Policy Area for paving thickness, reinforcement, etc.)
3. Scored Concrete Paving with 12" Accent Banding. If concrete, score joints on-center spacing equal to width of sidewalk. Expansion joints spacing shall be as required per the Geotechnical Report. If no Geotechnical Report exists, expansion joints shall be every fourth score joint minimum. (Refer to geotechnical report for the Southeast Policy Area for paving thickness, reinforcement, etc.)
4. Maintenance Road (use of Concrete or Asphalt to be determined by the City and CCSD). If concrete, score joints on-center spacing equal to width of sidewalk. Expansion joints spacing shall be as required per the Geotechnical Report. If no Geotechnical Report exists, expansion joints shall be every fourth score joint minimum. (Refer to geotechnical report for the Southeast Policy Area for paving thickness, reinforcement, etc.)
5. Shoulder. Material shall be 2' decomposed granite shoulder. Edging shall be as determined by the City and CCSD (refer to this chapter)
6. City of Elk Grove Type 3 Concrete Curb (refer to City of Elk Grove Standard Details)
7. Concrete Mowstrip (refer to City of Elk Grove Standard Details)
8. Redwood Headerboard (refer to City of Elk Grove Standard Details)
9. Colored Stamped Asphalt Enhanced Paving Crosswalks (refer to Chapter 2)
10. Community Wall with Community Pilaster (refer to Chapter 3)
11. Community Pilaster (refer to Chapter 3)
12. Low Pilaster (refer to Chapter 3)
13. Open View Fence (refer to Chapter 3)
14. Open View Fence with Low Wall (refer to Chapter 3)
15. Community Wood Fence (refer to Chapter 3)
16. Concrete Split Rail Fence (refer to Chapter 3)
17. Tubular Steel Fence with Accents (refer to Chapter 3)
18. Park Bollard. Stationary Bollard or Knock-down Bollard (refer to Chapter 3). Type shall be determined by City.
19. Post and Cable Fence (refer to Chapter 3)
20. Picnic Table - 6' Length (refer to Chapter 4)
21. Picnic Table - 8' Length (refer to Chapter 4)
22. Bench (refer to Chapter 4)
23. Trash Receptacle (refer to Chapter 4)
24. Drinking Fountain (refer to Chapter 4)
25. Lighted Bollard (refer to Chapter 4)
26. Bike Rack (refer to Chapter 4)
27. Informational Kiosk (refer to Chapter 4)
28. Tree Root Barrier (refer to Chapter 4)
29. Dog Litter Bag Dispenser (refer to Chapter 4)
30. Vehicular Bridge (refer to Chapter 4)
31. Land Uses (refer to the SPA, Chapter 2 Land Plan)
32. Greenways, Drainage Corridors and Drainage Facilities (refer to the SPA, Chapter 4)

C. GREENWAYS, DRAINAGE CORRIDORS & FACILITIES PLAN/SHARED-USE PATH PLAN

The Greenways, Drainage Corridors & Facilities Plan/Shared-Use Path Plan illustrates the approximate location in which greenways, drainage corridors, and drainage facilities exist within the Plan Area. This plan also shows the approximate locations of shared-use paths (a path that accommodates bicycle and pedestrian traffic) and how these paths connect and provide access within the Plan Area. Final location to be determined by City.

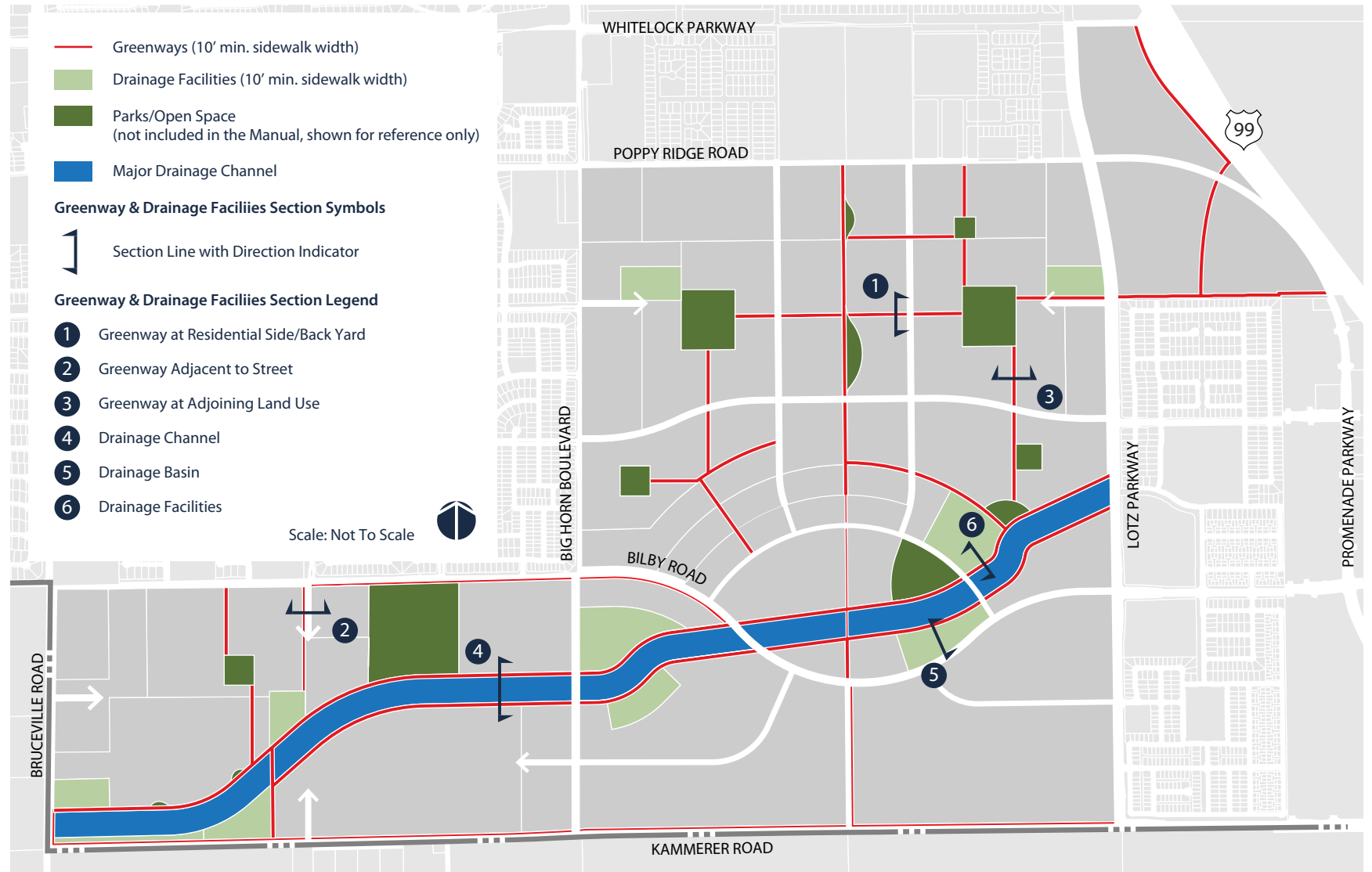

CHAPTER 5

GREENWAYS, DRAINAGE CORRIDORS & FACILITIES GREENWAYS, DRAINAGE CORRIDORS & FACILITIES

D. GREENWAYS, DRAINAGE CORRIDORS & FACILITIES

1. Greenways

Greenways create a pedestrian scale environment that interconnects the communities within the Plan Area. As linear extensions of the neighborhoods, land uses and parks, these greenway corridors provide passive and active recreational uses. Landscape amenities and site furnishings shall be located throughout greenways, emphasizing the pedestrian scale environment through these corridors. Additionally, greenways provide an excellent opportunity for extensive tree plantings. Tree plantings shall be located in informal groves to reinforce a park-like quality. Finally, the plant palette within greenways shall be consistent with the landscape concept of the community. Refer to Greenways Sections and Plan in this chapter for more information.

Design Elements

Refer to General Standards & Reference Items section this chapter for more information

- | | | |
|-------------------------------|---|---|
| 1. Primary Street Tree | a. Street | l. Trash Receptacle |
| 2. Primary Greenway Tree | b. City of Elk Grove Type 3 Concrete Curb | m. Drinking Fountain (not shown) |
| 3. Secondary Greenway Tree | c. Concrete Mowstrip | n. Lighted Bollard |
| 4. Accent Tree | d. Colored Asphalt Enhanced Paving | o. Bike Rack (not shown) |
| 5. Large Shrub (not shown) | e. Community Wall with Community Pilasters | p. Informational Kiosk (not shown) |
| 6. Medium Shrub | f. Community Pilaster | q. Tree Root Barrier |
| 7. Small Shrub | g. Low Pilaster | r. Dog Litter Bag Dispenser (not shown) |
| 8. Small Shrubs & Groundcover | h. Open View Fence or Open View Fence with Low Wall | s. Park Bollard |
| 9. Sodded Turf | i. Community Wood Fence | t. Shoulder |
| 10. Vine | j. Concrete Split Rail Fence | u. Pathway |
| | k. Bench | v. Land Use (varies (refer to the SPA, Chapter 2) |

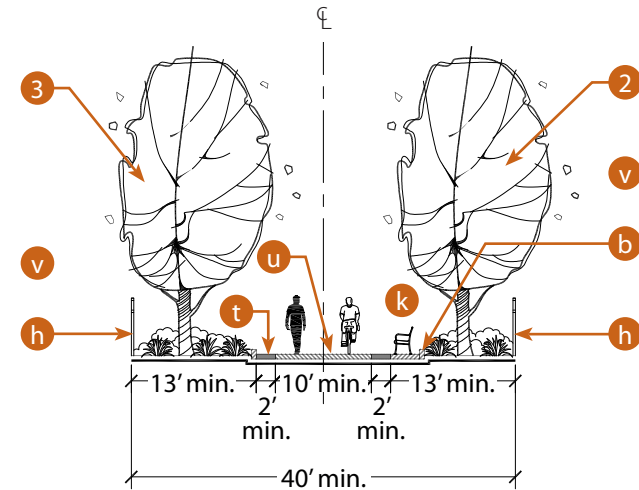

Greenway at Adjoining Land Use
Section - Not to Scale

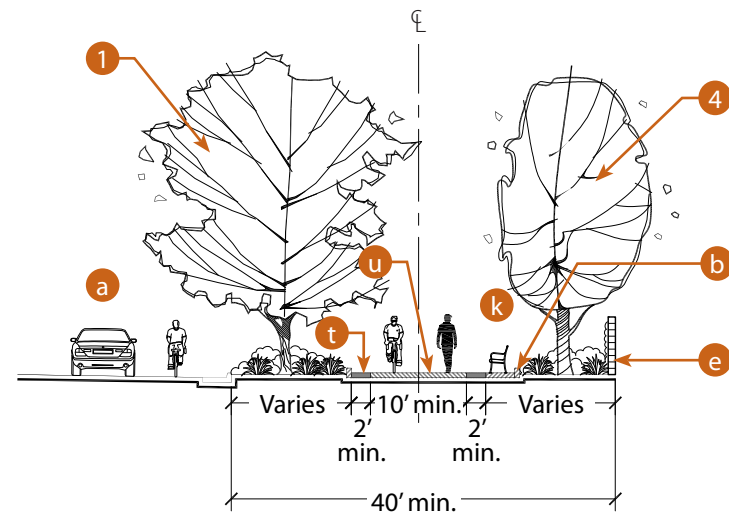

Greenway at Street
Section - Not to Scale

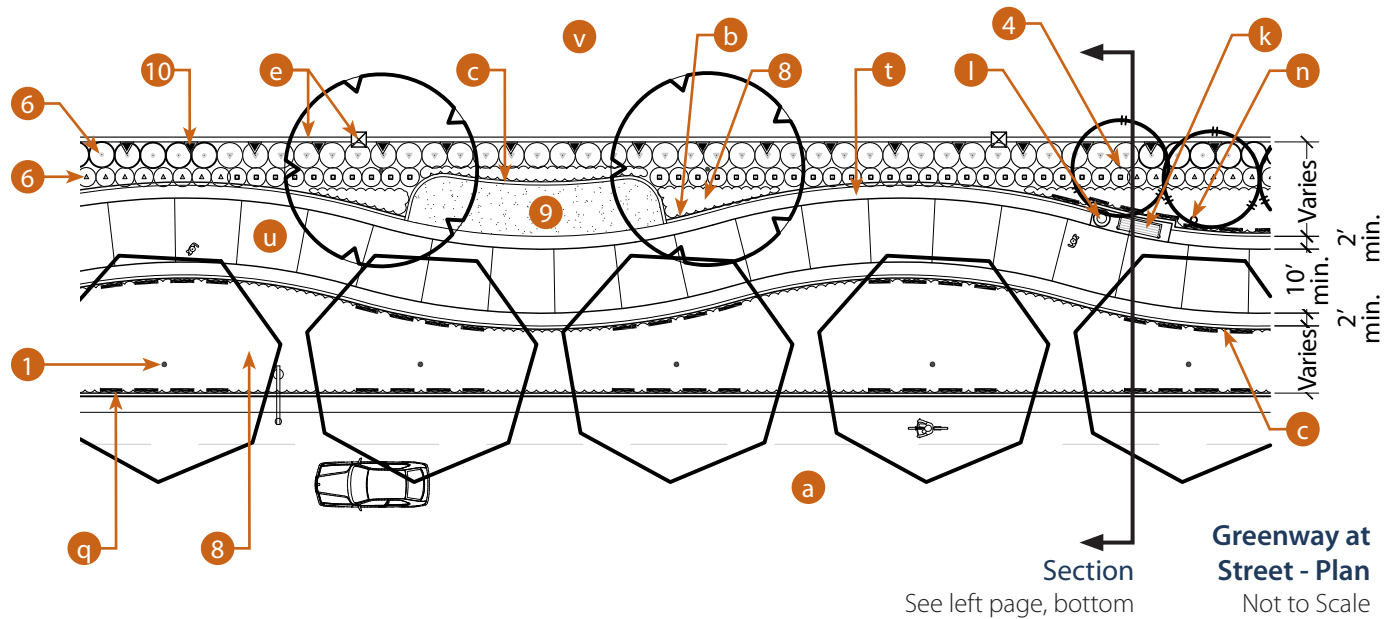
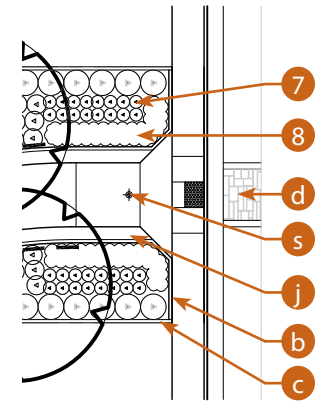
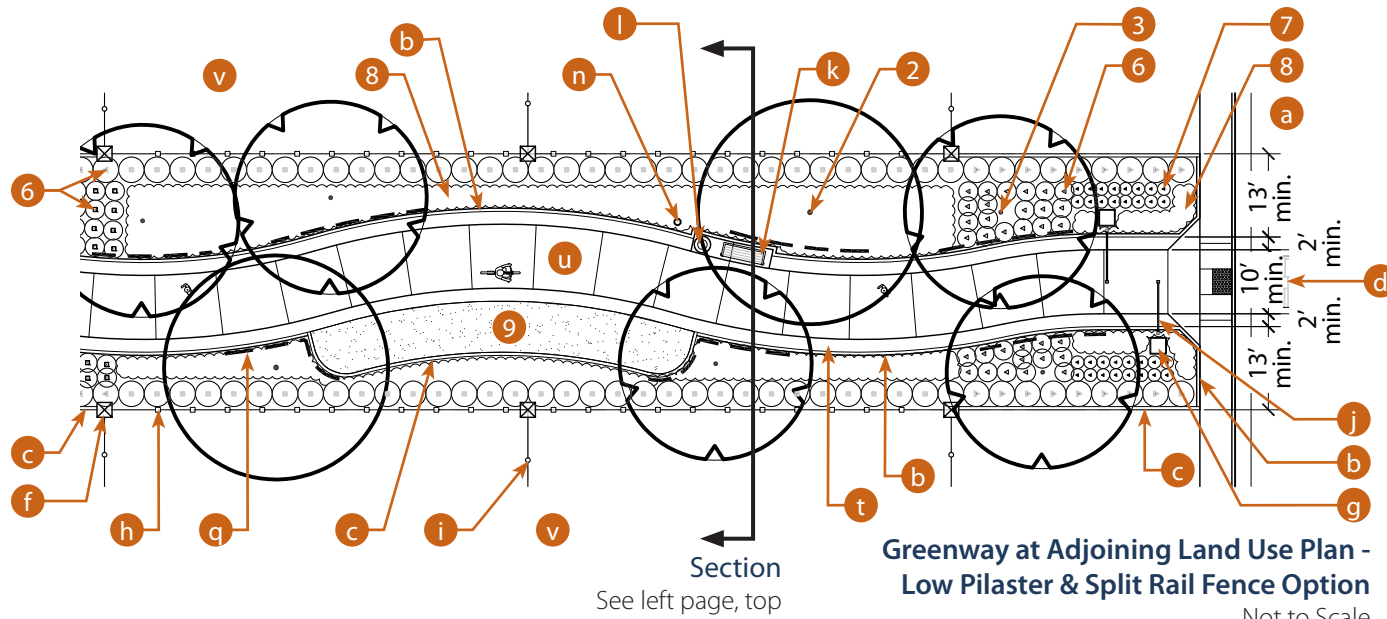

CHAPTER 5

GREENWAYS, DRAINAGE CORRIDORS & FACILITIES GREENWAYS, DRAINAGE CORRIDORS & FACILITIES

2. Major Drainage Channel

The Major Drainage Channel (Shed C Channel) is the primary conveyance facility for stormwater drainage throughout the Plan Area. It also includes a landscaped corridor on at least one side of the channel, with a trail that can double as a maintenance access road. The Major Drainage Channel serves a functional purpose, but is also part of the overall circulation plan and therefore shall be landscaped to help screen and accentuate elements of the drainage channel, creating more of a greenway setting. Additionally, these areas may provide active recreation uses, as well as passive pedestrian and bicycle uses. Landscape amenities and site furnishings shall be located throughout the passive pedestrian uses, creating a pedestrian scale environment through drainage areas. Tree plantings shall be located outside of the drainage areas in informal groves to reinforce a park-like quality. Additionally, the plant palette outside the drainage channel shall be consistent with the landscape concept of the community and the greenways. The drainage channel (including side slopes) shall be planted with acceptable plant material including trees, groundcover and grasses as required in the Drainage Facilities Plant Palette (refer to Chapter 6). Refer to Major Drainage Channel Section and Plan in this chapter for more information.

Design Elements

Refer to General Standards & Reference Items section this chapter for more information

- | | | | |
|--|---|-------------------------------------|---|
| 1. Primary Street Tree (not shown) | a. Scored Concrete Paving with 12" Accent Banding | i. Concrete Split Rail Fence | u. Dog Litter Bag Dispenser (not shown) |
| 2. Primary Greenway Tree | b. City of Elk Grove Type 3 Concrete Curb | j. Post and Cable Fence (not shown) | v. Vehicular Bridge |
| 3. Primary Drainage Area Tree | c. Concrete Mowstrip | k. Picnic Table - 6' Length | w. Pathway |
| 4. Secondary Greenway Tree | d. Colored Asphalt Enhanced Paving Crosswalks (not shown) | l. Picnic Table - 8' Length | x. Shoulder |
| 5. Accent Tree | e. Maintenance Road (not shown) | m. Park Bollard | y. Residential Land Use (refer to the SPA, Chapter 2) |
| 6. Accent Drainage Area Trees | f. Community Pilasters | n. Bench | z. Office Land Use (refer to the SPA, Chapter 2) |
| 7. Large Shrub (not shown) | g. Low Pilaster | o. Trash Receptacle | aa. Landscaping |
| 8. Medium Shrub | h. Open View Fence or Open View Fence with Low Wall | p. Drinking Fountain | |
| 9. Small Shrub | | q. Lighted Bollard | |
| 10. Small Shrub & Groundcover | | r. Bike Rack (not shown) | |
| 11. Sodded Turf | | s. Informational Kiosk | |
| 12. Drainage Area Side Slope Seed Mix | | t. Tree Root Barrier | |
| 13. Drainage Area Low Flow Bottom Seed Mix | | | |

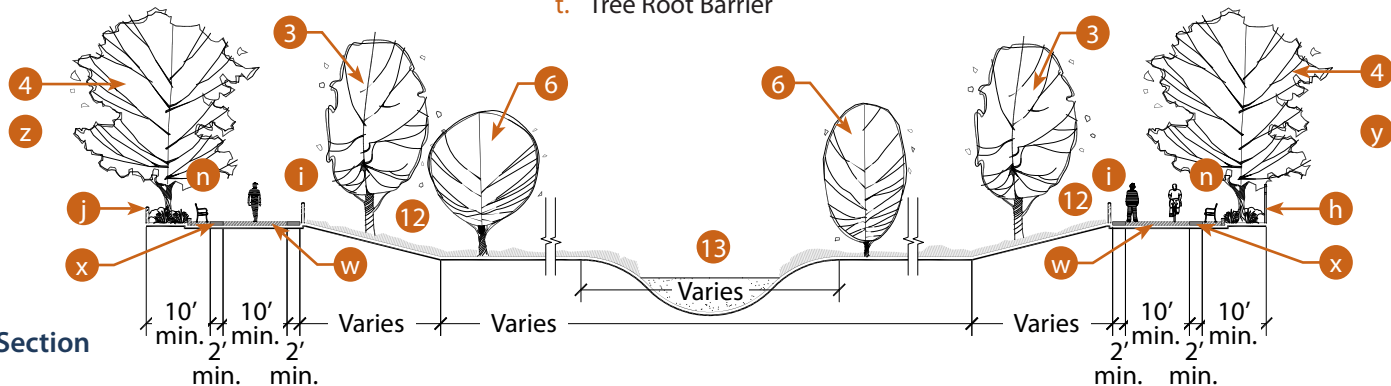

Major Drainage Channel - Section

Not to Scale

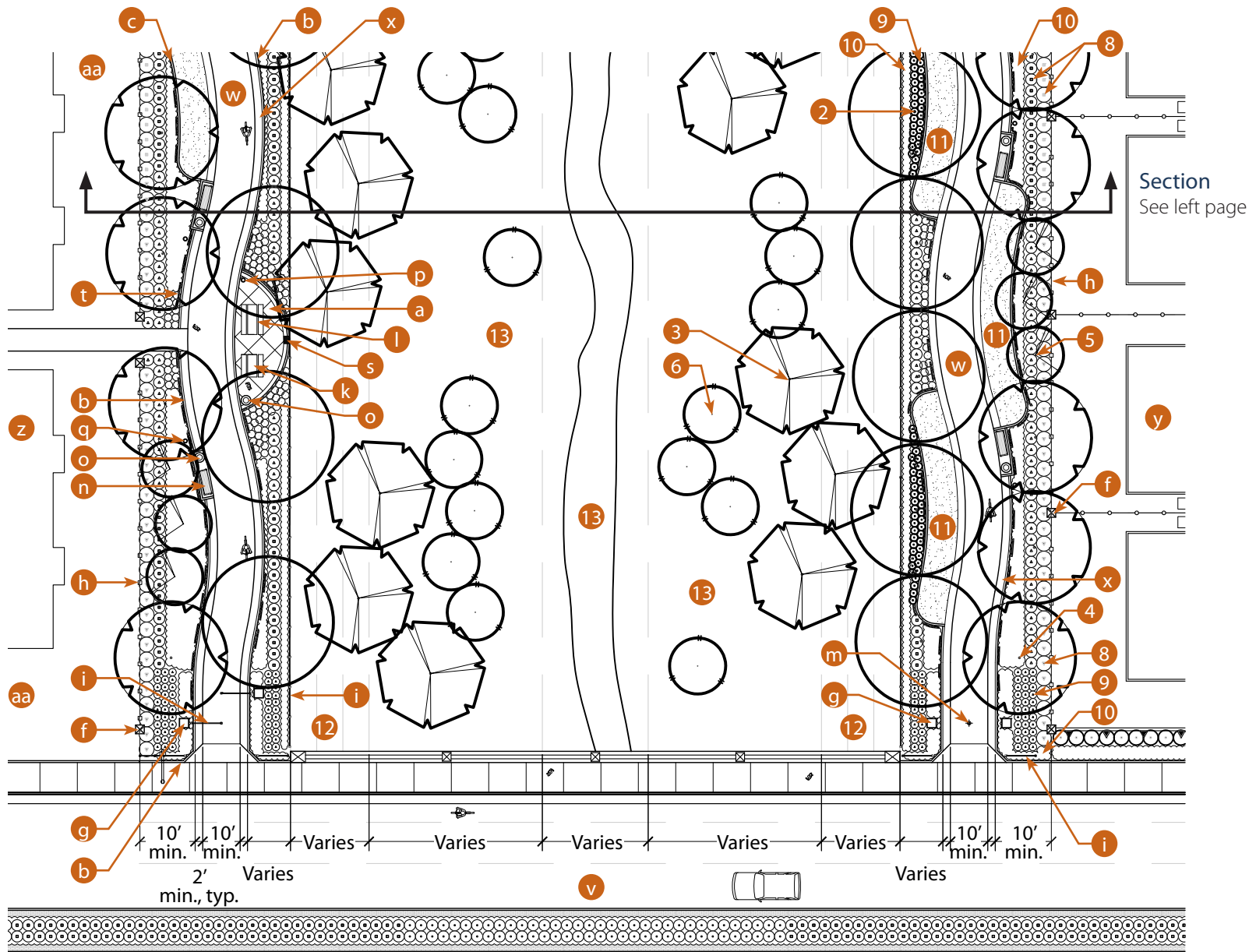

Note: This is a graphic representation of various land uses that exist along the Major Drainage Channel which may not actually occur. This graphic is for reference only.

Major Drainage Channel - Plan
Not to Scale

CHAPTER 5

GREENWAYS, DRAINAGE CORRIDORS & FACILITIES GREENWAYS, DRAINAGE CORRIDORS & FACILITIES

3. Detention Basin

Detention Basins are a stormwater storage facility that stores stormwater and gradually releases it into the major drainage channel. These drainage areas serve a functional purpose, but are also part of the overall circulation plan and therefore shall be landscaped to help screen and accentuate elements of the drainage areas, creating more of a greenway setting. Additionally, these areas may provide active recreation uses, as well as passive pedestrian and bicycle uses. Landscape amenities and site furnishings shall be located throughout the passive pedestrian uses, creating a pedestrian scale environment through drainage areas. Tree plantings shall be located outside of the drainage areas in informal groves to reinforce a park-like quality. Additionally, the plant palette outside the drainage areas shall be consistent with the landscape concept of the community. The drainage areas shall be planted with acceptable plant material including trees, groundcover and grasses as required in the Drainage Facilities Plant Palette (refer to Chapter 6). Refer to the Drainage Basin Section and Plan in this chapter for more information.

Design Elements

Refer to General Standards & Reference Items section this chapter for more information

1. Primary Greenway Tree
2. Primary Drainage Area Tree
3. Secondary Greenway Tree
4. Accent Tree
5. Accent Drainage Area Trees
6. Large Shrub (not shown)
7. Medium Shrub
8. Small Shrub (not shown)
9. Small Shrubs & Groundcover
10. Sodded Turf
11. Drainage Area Side Slope Seed Mix
12. Drainage Area Low Flow Bottom Seed Mix

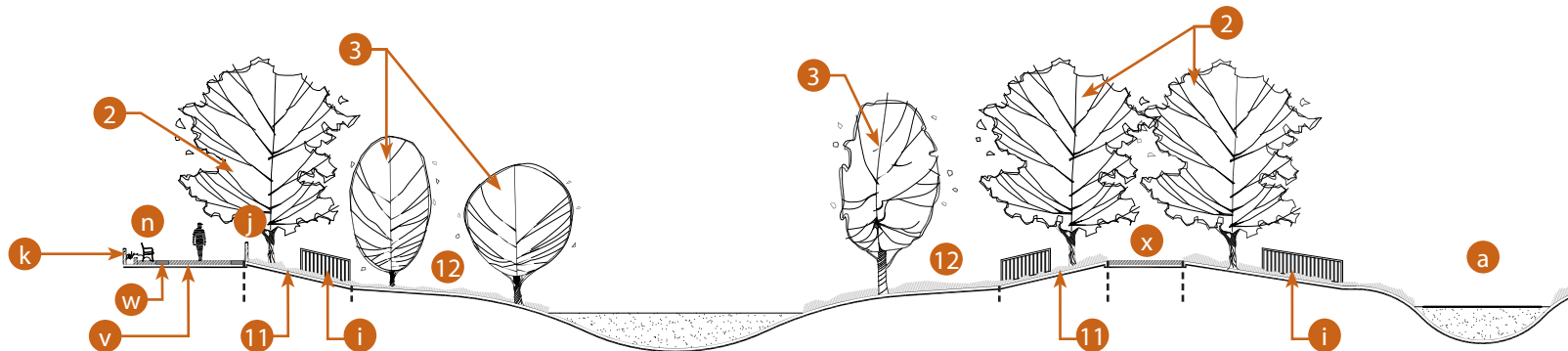

Detention Basin - Section

Not to Scale

Design Elements

Refer to General Standards & Reference Items section this chapter for more information

- a. Major Drainage Channel
- b. Scored Concrete Paving with 12" Accent Banding
- c. City of Elk Grove Type 3 Concrete Curb
- d. Concrete Mowstrip
- e. Colored Asphalt Enhanced Paving Crosswalks (not shown)
- f. Community Pilasters (not shown)
- g. Low Pilaster (not shown)
- h. Open View Fence or Open View Fence with Low Wall (not shown)
- i. Tubular Steel Fence with Accents
- j. Concrete Split Rail Fence
- k. Post and Cable Fence
- l. Picnic Table - 6' Length (not shown)
- m. Picnic Table - 8' Length (not shown)
- n. Bench
- o. Trash Receptacle
- p. Drinking Fountain
- q. Lighted Bollard
- r. Bike Rack (not shown)
- s. Informational Kiosk
- t. Tree Root Barrier
- u. Dog Litter Bag Dispenser (not shown)
- v. Pathway
- w. Shoulder
- x. Maintenance Road

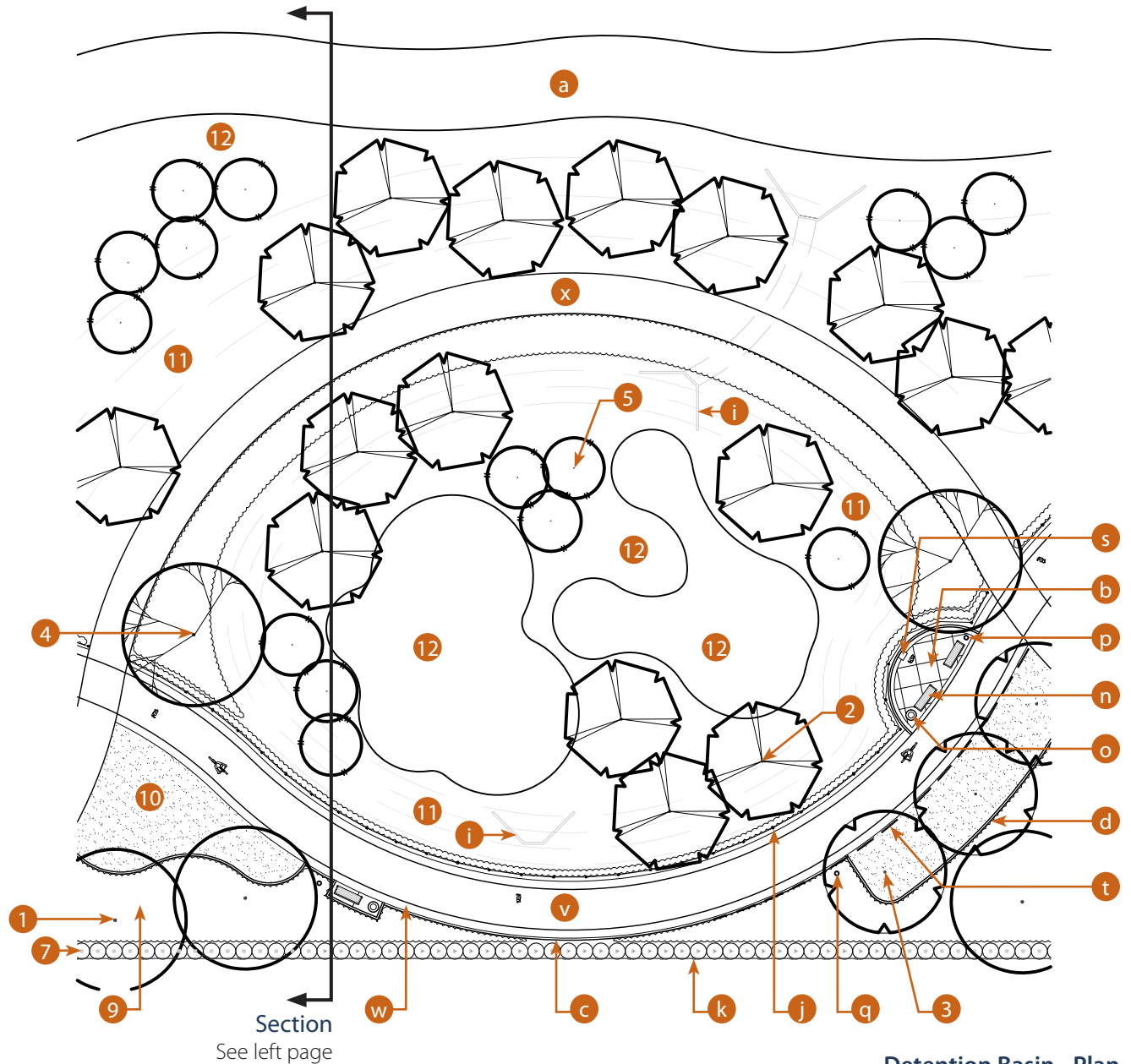

Detention Basin - Plan
 Not to Scale

CHAPTER 5

GREENWAYS, DRAINAGE CORRIDORS & FACILITIES GREENWAYS, DRAINAGE CORRIDORS & FACILITIES

4. Joint-Use Park/Detention Facility

The Joint-Use Park/Drainage Facility is a stormwater storage facility that stores stormwater and gradually releases it into the major drainage channel. These drainage areas serve a functional purpose, but are also part of the overall circulation plan and therefore shall be landscaped to help screen and accentuate elements of the drainage areas, creating more of a greenway setting. Additionally, these areas may provide active recreation uses, as well as passive pedestrian and bicycle uses. Landscape amenities and site furnishings shall be located throughout the passive pedestrian uses, creating a pedestrian scale environment through drainage areas. Tree plantings shall be located outside of the drainage areas in informal groves to reinforce a park-like quality. Additionally, the plant palette outside the drainage areas shall be consistent with the landscape concept of the community. The drainage areas shall be planted with acceptable plant material including trees, groundcover and grasses as required in the Drainage Facilities Plant Palette (refer to Chapter 6). Refer to the Drainage Basin as well as the Joint-Use Park/Drainage Facilities Section and Plan in this chapter for more information.

Design Elements

Refer to General Standards & Reference Items section this chapter for more information

1. Primary Drainage Area Tree
2. Accent Drainage Area Trees
3. Sodded Turf
4. Native Grass Seed Mix
5. Drainage Area Side Slope Seed Mix
6. Drainage Area Low Flow Bottom Seed Mix

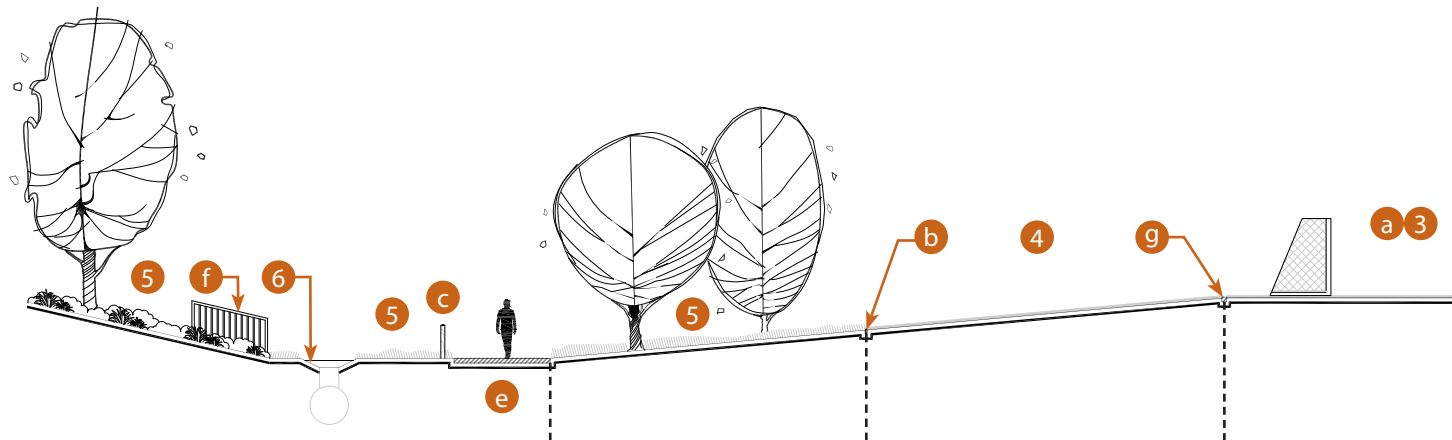

Joint-Use Park/Detention Facility - Section

Not to Scale

Design Elements

Refer to General Standards & Reference Items section this chapter for more information

- a. Park
- b. Redwood Headerboard
- c. Post and Cable Fence
- d. Dog Litter Bag Dispenser (not shown)
- e. Pathway
- f. Tubular Steel Fence with Accents
- g. Concrete Mowstrip

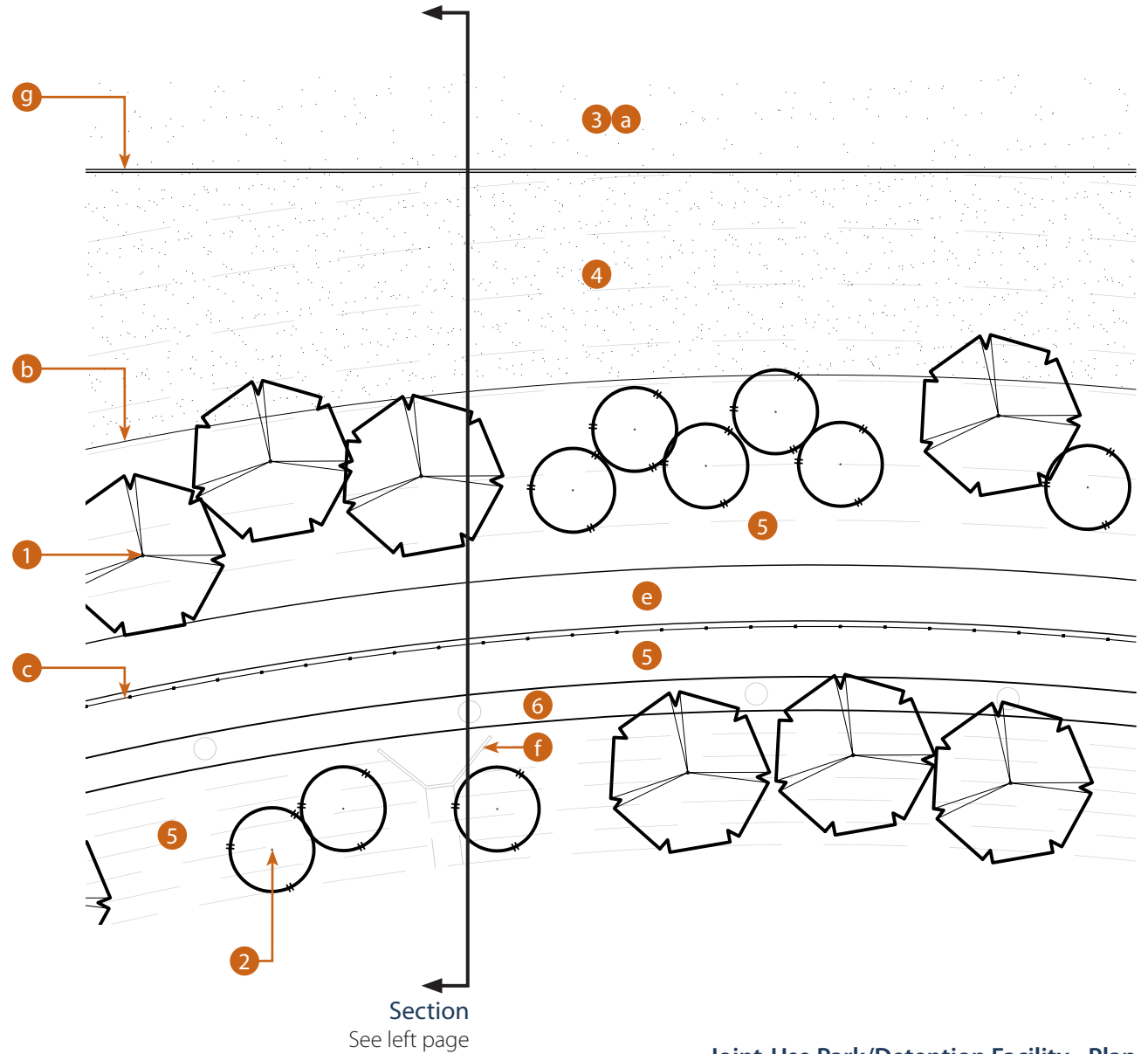

Joint-Use Park/Detention Facility - Plan
Not to Scale

CHAPTER 6

PLANT PALETTES, PLANTING & IRRIGATION REQUIREMENTS

SOUTHEAST POLICY AREA

SPECIAL PLANNING AREA

LANDSCAPE PLANNING PROTOTYPE MANUAL

CHAPTER 6

PLANT PALETTES, PLANTING & IRRIGATION REQUIREMENTS

A. CHAPTER OVERVIEW

This chapter establishes the identity and community character of the Plan Area through consistent plant palettes within various land uses, including drainage areas. These plant palettes highlight and strengthen the overall community design theme with distinctive plantings, emphasizing a pedestrian scale. Additionally, exhibits which reference the street tree layout are included. Finally, this chapter sets forth the prohibited plant palette and minimum planting and irrigation requirements that exist within the Plan Area, including general principles and planting requirements for design and installation. However, the information contained in this chapter does not supersede any planting and irrigation requirements set forth in existing City codes and design guidelines.

B. GENERAL PLANTING & IRRIGATION STANDARDS

1. General Planting Requirements

General design & planting requirements within the Plan Area are as follows:

1. The minimum planting size for a street tree or project site tree (including greenways and drainage areas) shall be sized at 15 gallon, and one-third (1/3) of all street trees and project site trees shall be 24" box or larger.
2. Street trees and background trees shall be a combination of deciduous and evergreen trees for purposes of screening and creating seasonal change. A minimum of 30% of the street trees and parking lot trees shall be evergreen species.
3. Trees shall be located at a 35' on center spacing within a perimeter landscape planter along interior property lines.
4. Screen trees shall be spaced at 30' on center spacing along interior property lines, between 5' to 10' off the property line.
5. Where non-residential property abuts residential property, evergreen trees shall be spaced at a 30' on center spacing, and large shrubs and vines shall be spaced at 8' on center spacing.
6. Where single family residential property abuts multifamily residential property, evergreen and deciduous trees shall be spaced at a 30' on center spacing.
7. Create diversity in the planting design by use of deciduous and evergreen plant material in a balanced, layered, and clustering combination.
8. Vines shall be evenly spaced against walls and fences.
9. Special attention shall be paid to any planting plan design in order to:
 - Preserve or frame desirable vistas or views of the existing landscape or natural site features, i.e. to parks, open spaces, the multi purpose drainage channel and greenways.
 - Screen or soften undesirable views of exposed residential backyards, retaining walls, cut / fill slopes and/or utility equipment. Evergreen trees and shrubs are required in these locations.
 - Screening for privacy. Evergreen trees or shrubs are required for these locations, particularly side yards between homes and at corner lots.
10. The proper spacing of trees, shrubs and groundcover shall allow adequate room for the plant material to grow into its natural form. Size at maturity is exceedingly important but should not be used as a basis for decreasing shrub quantities. Consult the Sunset Western Garden Book for Guidelines regarding the growth characteristics of plant material to be used.

PLANT PALETTES, PLANTING & IRRIGATION REQUIREMENTS
GENERAL PLANTING & IRRIGATION STANDARDS

11. The planting design shall be subject to the most current City of Elk Grove Model Water Efficient Landscape Ordinance (MWELO) and therefore careful selection and use of plant materials that have low-water consumption characteristics is imperative. Plant material that can tolerate occasional periods of reduced irrigation cycles will allow the landscaped environment the ability to withstand short-term drought conditions with the least amount of damage. Design water-conserving landscapes by:
 - Grouping plant material with similar water needs so they can be irrigated together (hydrozoning) and/or placing “thirsty” plant material in protected microclimates shielded from drying summer winds and direct sun.
 - Evaluating the need for high water use lawn areas. Groundcover with turf-like appearance may be satisfactory for landscaped areas while reducing water needs.
 - Selecting the correct plant material for the right planting situation.
12. The use of impermeable plastic weed barriers is not allowed within public improvements.
13. The use of crushed rock, gravel, lava rocks or other decorative “landscaping” rock for mulch is not allowed within public improvements.
14. All plant material shall comply with ANSI Z601 “Standard for Nursery Stock.” Trees shall be exceptionally heavy, symmetrical, tightly knit, and so trained or favored as to be superior in form for their species with regard to number of branches, compactness, and symmetry. Plants shall be sound, healthy, and vigorous, well branched and densely foliated when in leaf. They shall be free of disease, insect pests, eggs, or larvae. They shall have healthy, well developed root systems. Plants shall be free from physical damage or adverse conditions which would prevent thriving growth.
15. Root systems of plants shall be completely free of circling, kinked, or girdling roots.
16. Topsoil shall be fertile, friable sandy loam capable of sustaining healthy plant growth.
17. Excavated plant pits shall have positive drainage. Plant pits when fully flooded with water shall drain within 1 hour of filling.
18. All planter areas shall be properly prepared and amended in conformance to the recommendations of a professional soil fertility analysis as to the condition of the soil. The developer shall obtain five random soil samples for fertility analysis testing from each land use. Soil amending shall be as per those recommendations.
19. Sod shall be a certified turfgrass complying with ASPA specifications.
20. All sodded areas shall be properly soil amended, compacted, finish graded and rolled prior to the laying of the sod.
21. Native grass seed shall be provided from and mixed by a certified dealer. Seed mixture shall be uncontaminated, dry and free of pests as well as labeled with the manufacturer’s guaranteed analysis, germination rate, and purity rate. Seed shall be of standard, approved, and first-grade quality and shall be in prime condition when installed and accepted.
22. Established seeded native grass areas shall exhibit a uniform stand in good health and vigor, free of noxious or invasive weeds, and demonstrating 90% coverage, or effective competitiveness against non-native species.
23. The location of trees, shrubs, and groundcover shall be adjusted in field as necessary to accommodate and avoid existing utilities, etc.
24. Where trees are planted within 10’ of paving, install tree root barriers (refer to Chapter 4).

CHAPTER 6

PLANT PALETTES, PLANTING & IRRIGATION REQUIREMENTS GENERAL PLANTING & IRRIGATION STANDARDS

25. Where trees are planted in lawn areas, remove lawn from around trunk to create a 2'-0" diameter basin.
26. Pre-emergent herbicides shall be applied to shrub and groundcover planting areas to control weeds. Do not apply to hydroseeded or turf areas.
27. A 3" layer of walk-on type bark mulch shall be located in all planter areas around trees, shrubs and groundcover within public improvements.
28. All landscaping shall be installed per the latest edition of the City of Elk Grove Standard Specifications and details.
29. The City and Cosumnes Community Services District (CCSD) shall be contacted a minimum of 48 hours, prior to the commencement of work on any public improvement project, to set up a pre-construction meeting. Inspections will include:
 - Pre-Planting Inspection
 - Plant Material Delivery Inspection
 - Pre-Maintenance Period Inspection
30. Any plant substitutions not included in the General Landscape Plant Palette shall be approved by the City and CCSD.
31. Tree stakes and ties shall be as specified by the City and/or CCSD.

2. General Irrigation Requirements

General design & irrigation requirements within the Plan Area are as follows:

1. All irrigation systems installed within the Plan Area shall comply with the City of Elk Grove Water Efficient Landscape Ordinance (MWELO), EGMC Chapter 14.10, as well as any future requirements associated with water conserving irrigation design requirements.
2. All new irrigation systems located within publicly maintained landscape areas of the Plan Area shall be reviewed and approved by the City and CCSD. Contact the CCSD at (916) 405-5309 for more information on specific irrigation requirements.
3. Irrigation systems shall be designed and installed in conformance with the City's Standard Specifications and Details.
4. Any change or modification to any irrigation system located within the Plan Area must be approved by the City and comply with all state and local irrigation requirements in existence at the time of new irrigation installation or modification to existing irrigation.

C. PLANT PALETTES

1. General Landscaping Plant Palette

The General Landscape Plant Palette for the Plan Area has been developed to ensure a cohesive element of design throughout the community. This plant palette is designed to achieve a strong delineation between public ROW, corresponding landscape areas, open space and drainage areas, greenways, and community focal points. Basic criteria for the selection and use of specific plant material contained in the plant palette are as follows:

1. All plant material has been selected for its compatibility with the environmental conditions of the City of Elk Grove and Sacramento region.
2. When selecting plant material and planting locations, the designer shall consider the site as a whole, relationship to building structures and other site amenities, solar/climatic orientation as well as utilize water-wise materials and practices for water conservation.
3. All installed plant materials shall be located to provide clear view for traffic and public safety in compliance with the City visibility requirements.
4. All installed landscapes shall be irrigated by an automatic irrigation system utilizing water-conserving design.
5. Selected plant material shall be appropriately-sized based on the size and environmental constraints of the site. Plant material shall be planted in locations large enough to accommodate their mature size and spaced appropriately to reduce/prevent the need for excessive pruning.

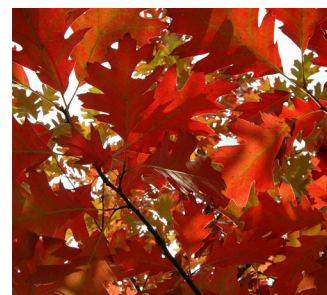

Quercus rubra
Red Oak

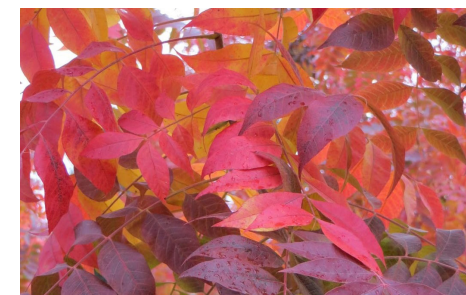

Pistacia chinensis 'Keith Davey'
Chinese Pistache

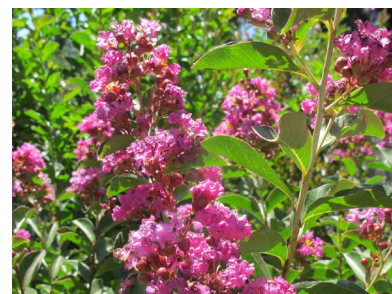

Lagerstroemia indica x fauriei
Crape Myrtle



Hemerocallis sp.
Evergreen Daylily



Lavandula dentata
French Lavender



Calamagrostis acutiflora 'Karl Foerster'
Feather Reed Grass

CHAPTER 6

PLANT PALETTES, PLANTING & IRRIGATION REQUIREMENTS PLANT PALETTES

The following represents the General Landscape Plant Palette within the Plan Area. Any proposed amendments shall be approved by the City.

SOUTHEAST POLICY AREA PLANT LEGEND - GENERAL LANDSCAPE PLANT PALETTE				
Botanical Name	Common Name	Size (h x w)	WUCOLS Water Use	Notes
Primary Street & Greenway Trees				
<i>Acer rubrum</i> 'October Glory'	Red Maple	45' x 35'	M	-
<i>Celtis australis</i>	European Hackberry	55' x 45'	M	-
<i>Fraxinus oxycarpa</i> 'Raywood'	Raywood Ash	60' x 60'	M	-
<i>Ginkgo biloba</i> 'Princeton Sentry'	Maidenhair Tree	45' x 25'	M	Male variety only
<i>Liriodendron tulipifera</i>	Tulip Tree	70' x 40'	M	-
<i>Pistacia chinensis</i> 'Keith Davey'	Chinese Pistache	30' x 30'	L	Male variety only
<i>Quercus agrifolia</i>	Coast Live Oak	60' x 60'	L	-
<i>Platanus acerfolia</i> 'Bloodgood'	London Plane Tree	60' x 30'	M	Greenways only
<i>Quercus lobata</i>	Valley Oak	50' x 50'	L	-
<i>Quercus rubra</i>	Red Oak	65 x 65'	M	-
<i>Quercus shumardii</i>	Shurmard Red Oak	60' x 60'	L	-
<i>Quercus virginiana</i>	Southern Live Oak	40' x 60'	M	-
<i>Quercus wislizeni</i>	Interior Live Oak	40' x 60'	L	-
<i>Tilia cordata</i> 'Greenspire'	Little Leaf Linden	40' x 30'	M	-
<i>Ulmus parvifolia</i>	Chinese Elm	50' x 50'	M	-
<i>Zelkova serrata</i> 'Village Green'	Zelkova	50' x 40'	M	-
Secondary Street, Greenway, & Median Trees				
<i>Acer beurgerianum</i>	Trident Maple	25' x 25'	M	-
<i>Acer rubrum</i> 'October Glory'	Red Maple	45' x 35'	M	-
<i>Carpinus betulus</i> 'Fastigiata'	European Hornbeam	40' x 20'	M	-
<i>Cinnamomum camphora</i>	Camphor Tree	50' x 60'	M	Greenways only
<i>Ginkgo biloba</i> 'Princeton Sentry'	Maidenhair Tree	45' x 25'	M	Male variety only
<i>Koelreuteria paniculata</i>	Golden Rain Tree	35' x 35'	M	-
<i>Lagerstroemia indica</i> x <i>fauriei</i>	Crape Myrtle	40' x 30'	L	Standard

SOUTHEAST POLICY AREA PLANT LEGEND - GENERAL LANDSCAPE PLANT PALETTE				
Botanical Name	Common Name	Size (h x w)	WUCOLS Water Use	Notes
Secondary Street, Greenway, & Median Trees - continued				
<i>Calocedrus decurrens</i>	Incense Cedar	55' x 10'	M	-
<i>Magnolia grandiflora</i> 'Russet'	Russet Magnolia	35' x 20'	M	-
<i>Pinus canariensis</i>	Canary Island Pine	60' x 30'	L	Not used in Medians
<i>Pyrus calleryana</i> 'Red Spire'	Callery Pear	30' x 30'	M	-
<i>Pyrus calleryana</i> 'Aristocrat'	Aristocrat Pear	30' x 20'	M	-
Specimen Trees (Project Entry)				
<i>Lagerstroemia indica</i> spp.	Crape Myrtle	30' x 30'	L	Multi-stem
Major Accent Trees (Project Entry)				
<i>Carpinus betulus</i> 'Fastigiata'	European Hornbeam	40' x 20'	M	-
Accent Trees and Median Accent Trees				
<i>Acer palmatum</i>	Japanese Maple	15' x 15'	M	-
<i>Arbutus x</i> 'Marina'	Strawberry Tree	45' x 30'	L	Do not use near CCSD maintained hardscape
<i>Cupressus sempervirens</i>	Italian Cypress	55' x 15'	M	-
<i>Ginkgo biloba</i> 'Autumn Gold'	Maidenhair Tree	45' x 30'	M	Male variety only
<i>Lagerstroemia indica x fauriei</i>	Crape Myrtle	40' x 30'	L	Multi-stem
<i>Magnolia grandiflora</i> 'Little Gem'	Little Gem Magnolia	15' x 10'	M	-
<i>Olea europaea</i> 'Swan Hill'	Fruitless Olive	15' x 15'	L	-
<i>Podocarpus elongates</i> 'Monmal'	Icee Blue Yellow-Wood	20' x 20'	M	-
<i>Prunus cerasifera</i> 'Krauter Vesuvius'	Purple Leaf Plum	15' x 15'	M	-
Palms (Only to be Used as Accent Trees in Commercial Land Use Only)				
<i>Phoenix canariensis</i>	Canary Island Date Palm	50' x 40'	L	Commercial Land Use only
<i>Phoenix roebelenii</i>	Pygmy Date Palm	8' x 8'	M	
<i>Washingtonia robusta</i>	Mexican Fan Palm	100' x 1'	L	

CHAPTER 6

PLANT PALETTES, PLANTING & IRRIGATION REQUIREMENTS PLANT PALETTES

SOUTHEAST POLICY AREA PLANT LEGEND - GENERAL LANDSCAPE PLANT PALETTE				
Botanical Name	Common Name	Size (h x w)	WUCOLS Water Use	Notes
Trees for Use Under Powerlines (as approved by SMUD)				
Contact the SMUD Vegetation Management Department for tree species recommended for use under powerlines.				
Large Shrubs (6' and wider)				
<i>Arctostaphylos densiflora</i> 'Howard McMinn'	Vine Hill Manzanita	6' x 6'	L	-
<i>Cercis occidentalis</i>	Western Redbud	15' x 10'	L	-
<i>Dodonaea viscosa</i> 'Purpurea'	Hopseed Bush	12' x 6'	L	-
<i>Escallonia</i> 'Compakta'	Compact Escallonia	3' x 6'	M	Specified variety only
<i>Heteromeles arbutifolia</i>	Toyon	6' x 6'	L	-
<i>Laurus nobilis</i>	Bay Laurel	10' x 10'	L	Shrub form
<i>Ligustrum japonicum</i>	Wax Leaf Privet	10' x 8'	L	-
<i>Nerium oleander</i> 'Petite Pink'	Oleander	4' x 6'	L	-
<i>Osmanthus fragrans</i>	Fragrant Osmanthus	10' x 10'	M	-
<i>Photinia x fraseri</i>	Photinia	12' x 10'	M	-
<i>Pittosporum tobira</i> 'Variegata'	Variegated Mock Orange	6' x 6'	M	-
<i>Prunus laurocerasus</i> 'Otto Luyken'	Cherry Laurel	5' x 7'	M	-
<i>Viburnum tinus</i> 'Spring Bouquet'	Spring Bouquet Viburnum	6' x 6'	M	-
<i>Xylosma congestum</i> 'Compacta'	Shiny Xylosma	10' x 10'	L	Shrub form. Specified variety only.
Medium Shrubs (2' to 5.5' wide)				
<i>Abelia grandiflora</i> 'Kaleidoscope'	Abelia	2' x 3'	M	-
<i>Arbutus unedo</i> 'Compacta'	Compact Strawberry Bush	6' x 5'	L	-
<i>Buxus</i> spp.	Boxwood	4' x 4'	M	Shear to size
<i>Coleonema</i> 'Sunset Gold'	Golden Breath of Heaven	5' x 4.5'	M	-
<i>Cistus x purpureus</i>	Orchid Rockrose	4' x 5'	L	-
<i>Dietes bicolor</i> or <i>vegeta</i>	African Iris	3' x 2'	L	-
<i>Ilex cornuta</i> 'Carissa'	Carrisa Holly	3' x 4'	M	-
<i>Lavendula dentata</i>	French Lavender	3' x 3'	L	-

SOUTHEAST POLICY AREA PLANT LEGEND - GENERAL LANDSCAPE PLANT PALETTE				
Botanical Name	Common Name	Size (h x w)	WUCOLS Water Use	Notes
Medium Shrubs (2' to 5.5' wide) - continued				
Lavendula stoechas	Spanish Lavender	3' x 3'	L	-
Leptospermum scoparium 'Ruby Glow'	Red New Zealand Tea Tree	8' x 5'	M	-
Loropetalum chinense	Fringe Flower	4' x 4'	M	Varieties under 5' Only
Nandina domestica	Heavenly Bamboo	3' x 3'	M	Varieties under 5' Only
Phormium tenax	New Zealand Flax	5' x 3'	L	Varieties under 5' Only
Pittosporum tenuifolium 'Golf Ball'	Golf Ball Kohuhu	3' x 3'	M	-
Raphiolepis indica 'Clara'	Indian Hawthorne	4' x 4'	L	-
Raphiolepis umbellata 'Minor'	Dwarf Yeddo Hawthorne	6' x 3'	L	-
Rosa 'Flowering Carpet Red'	Red Flowering Carpet Rose	2' x 3'	M	-
Rosa 'Flowering Carpet White'	White Flowering Carpet Rose	2' x 3'	M	-
Small Shrubs (.5' to 2.5' wide) and Groundcovers				
Arctostaphylos sp.	Manzanita	Varies	L-M	As approved by CCSD
Agapanthus africanus 'Queen Anne'	Queen Anne Agapanthus	1.5' x 1.5'	M	-
Baccharis pilularis 'Pigeon Point'	Dward Coyote Brush	2.5' x 6'	L	-
Coprosma petriei 'Verde Vista'	Creeping Coprosma	2' x 8'	L	-
Euonymus fortunei 'Coloratus'	Purple Winter Creeper	2' x 6'	M	-
Gazania spp.	Gazania	.5' x 2'	M	-
Hemerocallis Hybrid (Evergreen)	Evergreen Daylily	1' x 1'	M	-
Juniper spp.	Juniper	Varies	L	Groundcover varieties only
Myoporum parvifolium	Creeping Myoporum	.5' x 4'	L	-
Myrtus communis 'Compacta'	Dwarf Myrtle	2' x 2'	L	-
Pittosporum tobira 'Wheeler's Dwarf'	Wheeler's Dwarf Japanese Mock Orange	2' x 4'	M	-
Raphiolepis indica 'Ballerina'	Dwarf Indian Hawthorne	2' x 3'	M	-
Rosmarinus officinalis 'Collingwood Ingram'	Collingwood Ingram Rosemary	2.5' x 4'	L	Specified variety only
Trachelospermum asiaticum	Asian Jasmine	1.5' x 6'	M	-

CHAPTER 6

PLANT PALETTES, PLANTING & IRRIGATION REQUIREMENTS PLANT PALETTES

SOUTHEAST POLICY AREA PLANT LEGEND - GENERAL LANDSCAPE PLANT PALETTE				
Botanical Name	Common Name	Size (h x w)	WUCOLS Water Use	Notes
Small Shrubs (.5' to 2.5' wide) and Groundcovers - continued				
Trachelospermum jasminoides	Star Jasmine	3' x 5'	M	-
Verbena spp.	Verbena	1' x 3'	L	
Vinca minor	Periwinkle	.5' x 6'	M	-
Vines				
Ficus Pumila	Creeping Fig	Spreads up to 25'	M	Self-Clinging
Hardenbergia violacea	Lilac Vine	Spreads up to 15'	M	Requires Support
Jasminum polyanthum	Pink Jasmine	Spreads up to 20'	M	Requires Support
Parthenocissus tricuspidata	Boston Ivy	Spreads up to 40'	M	Self-Clinging
Rosa banksiae 'Lutea'	Lady Banks Rose	Spreads up to 15'	L	Requires Support
Wisteria sinensis	Chinese Wisteria	Spreads up to 25'	M	Requires Support. Use on Arbor Only.
Grasses				
Calamagrostis x acutiflora 'Karl Foerster'	Feather Reed Grass	5' x 3'	L	-
Carex divulsa	Berkeley Sedge	1' x 1'	L	-
Festuca glauca 'Elijah Blue'	Blue Fescue	1' x 1'	L	-
Helictotrichon sempervirens	Blue Oat Grass	1.5' x 1.5'	L	-
Muhlenbergia capillaris	Pink Muhly	3' x 3'	L	-
Muhlenbergia rigens	Deer Grass	5' x 5'	L	-
Sodded Turf				
'Bolero Plus'	Sodded Turf	High Water Use. Available through: Delta Blue Grass Co.* Locations to be approved by the City.		
Biofiltration Sod	Sodded Bioswale Grass	High Water Use. Available through: Delta Blue Grass Co.* (needs initial irrigation)		
No Mow Fescue 'Mow Free'	Mow Free Fescue Sod	High Water Use. Available through: Delta Blue Grass Co.*		
Native Grass Seed Mix				
Native Ornamental Fine Fescue Mix	Native Fescue Seed Blend	Low to Medium Water Use. Available through: Pacific Coast Seed, Inc.*		

* = Or approved equivalent

2. Drainage Areas Plant Palette

The Drainage Areas Plant Palette has been developed for the Plan Area and must be used in the entire Major Drainage Channel, all Detention Basins and all Joint-Use Park/Detention Facilities within the Plan Area. No substitutions can be made to any plant material specified in the Drainage Area Plant Palette. Refer to Chapter 5 for planting location requirements associated with plants contained in the Drainage Area Plant Palette.

SOUTHEAST POLICY AREA PLANT LEGEND - DRAINAGE AREAS PLANT PALETTE				
Botanical Name	Common Name	Size (h x w)	WUCOLS Water Use	Notes
Drainage Area Trees				
<i>Platanus racemosa</i>	California Sycamore	60' x 35'	M	-
<i>Salix laevigata</i>	Red Willow	30' x 35'	H	Locate near ear low-flow edge
Drainage Area Side Slopes Seed Mix				
<i>Artemisia douglasiana</i>	Mugwort	3' x 2.5'	L	-
<i>Hordeum brachyantherum</i>	Meadow Barley	1' x .5'	L	-
<i>Leymus triticoides</i> 'Yolo'	Yolo Creeping Wildrye	2' x 3'	L	-
<i>Nasella cernua</i>	Nodding Stipa	3' x 1.5'	L	-
<i>Poa secunda</i>	Pine Bluegrass	.75' x 1'	L	-
<i>Vulpia microstachys</i>	Small Fescue	.75' x 1'	L	-
Drainage Area Low Flow Bottom Seed Mix				
<i>Achillea millefolium</i>	White Yarrow	2.5' x 2.5'	L	-
<i>Deschampsia cespitosa</i>	Tufted Hairgrass	2.5' x 1.5'	L	-
<i>Eleocharis macrostachya</i>	Common Spikerush	2' x 2'	H	-
<i>Hordeum brachyantherum</i>	Meadow Barley	1' x .5'	L	-
<i>Juncus bufonius</i>	Toad Rush	.75' x 1'	H	-
<i>Leymus triticoides</i> 'Yolo'	Yolo Creeping Wildrye	2' x 3'	L	-
<i>Scirpus acutus</i>	Hard-Stem Bulrush	5' x 5'	H	-
<i>Scirpus californicus</i>	California Bulrush	5' x 5'	H	-
<i>Typha latifolia</i>	Broad-Leaved Cattail	5' x 5'	H	-
<i>Vulpia microstachys</i>	Small Fescue	.75' x 1'	L	-

CHAPTER 6

PLANT PALETTES, PLANTING & IRRIGATION REQUIREMENTS PLANT PALETTES

3. Prohibited Plant List

The Plan Area contains both publicly and privately owned and maintained property. All plant material installed within publicly owned and maintained areas must be selected with care, and to the satisfaction of the City and CCSD. Certain plant material has already been determined to be prohibited by each agency. The plants listed in this chapter shall not be utilized in any publicly maintained property including right-of-ways, medians, corresponding landscape areas, open space or drainage areas, greenways, and community focal points. Additionally, the City and CCSD may also prohibit the use of additional plants not specified on this list. Therefore it is necessary to contact the City and CCSD during the design phase to confirm potential plant material selections are not prohibited. For a palette of approved plant material, refer to the General Landscape Plant Palette.

Privately owned and maintained properties may utilize some plant material referenced on the prohibited plant list.



Eucalyptus spp.
Eucalyptus



Chamaerops spp.
Palm



Ceanothus spp.
Ceanothus



Escallonia spp.
Escallonia



Pennisetum spp.
Fountain Grass

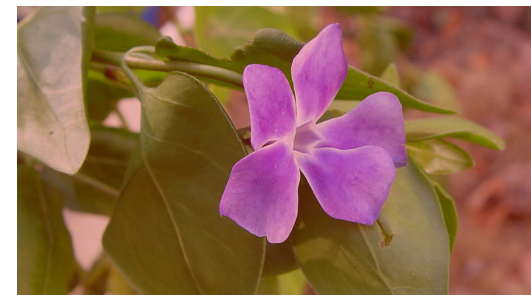

Vinca major
Greater Periwinkle

SOUTHEAST POLICY AREA PLANT LEGEND - PROHIBITED PLANT LIST				
Botanical Name	Common Name	Size (h x w)	WUCOLS Water Use	Notes
Prohibited Trees				
Eucalyptus spp.	Eucalyptus species	-	-	Prohibited in all areas
Ligustrum sp.	Privet	-	-	Prohibited in all areas
Liquidambar spp.	Sweet Gum species	-	-	Prohibited in all areas
Archontophoenix, Brahea, Chamaerops, Cocos, Jubaea, Livistona, Phoenix, Rhapidophyllum, Rhopalostylis, Sabel, Syagrus, Trachycarpus, Washingtonia spp.	Palm species	-	-	Only allowed in commercial land use
Prohibited Shrubs and Groundcovers				
Arctostaphylos spp. (unless otherwise noted)	Manzanita species	-	-	Only prohibited in areas maintained by CCSD
Baccharis spp.	Dwarf Coyote Brush	-	-	Only prohibited in areas maintained by CCSD
Ceanothus spp.	Ceanothus species	-	-	Prohibited in all areas
Escallonia spp.	Escallonia species	-	-	Only prohibited in areas maintained by CCSD
Lavandula spp. (unless otherwise noted)	Lavender species	-	-	Only prohibited in areas maintained by CCSD
Nerium spp. (unless otherwise noted)	Oleander	-	-	Only prohibited in areas maintained by CCSD
Pennisetum spp.	Fountain Grass species	-	-	Prohibited in all areas
Photinia spp.	Photinia species	-	-	Only prohibited in areas maintained by CCSD
Pyracantha spp.	Pyracantha species	-	-	Prohibited in all areas
Xylosma spp.	Xylosma species	-	-	Only prohibited in areas maintained by CCSD
Vinca major	Greater Periwinkle	-	-	Prohibited in all areas

CHAPTER 6

PLANT PALETTES, PLANTING & IRRIGATION REQUIREMENTS MAJOR STREET TREE PLAN

D. PRIMARY STREET TREE PLAN



SOUTHEAST POLICY AREA

SPECIAL PLANNING AREA

LANDSCAPE PLANNING PROTOTYPE MANUAL

ADOPTED AUGUST 2016



CITY OF
ELK GROVE

PROUD HERITAGE. BRIGHT FUTURE.