

## Attached Patio Cover Sample

March 2005 (Revised May 2008)

### General

#### Purpose

The sample illustrations show how an attached unenclosed patio structure may be built utilizing the 2007 California Building Code (CBC) “Conventional Light Wood-Frame Construction Guidelines”. The conventional method allows “repetitive” members in the designs of walls, floors and ceiling, are prescriptive, and ordinarily do not require a structural design to comply with the code. For information regarding plan submittals and specific design limitations for residential patio covers refer to Policy & Procedure No. B-04-04 “Plan Submittal for Patio Covers and Similar Accessory Buildings (Sheds • Arbors • Trellises).

### Design Provisions

#### Patio Cover Limitations

The following patio cover illustrations are only applicable in residential dwellings classified as R-3 Occupancies.

Patio covers are **not** designed or intended to be used as room additions which require compliance with code provisions such as heating, waterproofing, and normal live and wind loads. Furthermore, patio covers cannot always be converted to complying room additions.

#### What information is needed to obtain a building permit?

Included in the plan submittal should be the following information which clearly depicts the proposed patio cover construction and its relationship to the entire lot. Information such as the size and spacing of all framing members; attachment detail to the exterior wall; roof covering material, connection specifications for beam to post, and for post to footing, etc.

Samples of plans are illustrated on the next pages for clarification and additional plan information may be requested if the plans provided are unclear or incomplete. If the patio structure consists of a simple design similar to the sample illustrations, you may refer to the tables on page 4 for allowable size & spacing of structural members. Otherwise, a structural analysis/evaluation may be required by a professional engineer licensed in the State of California for the design of structures of unusual shape and/or structures supporting tile roofing materials (i.e., cellulose, cement).

- Site Plan
- Elevation(s)
- Roof Framing
- Cross-Section
- Framing Details

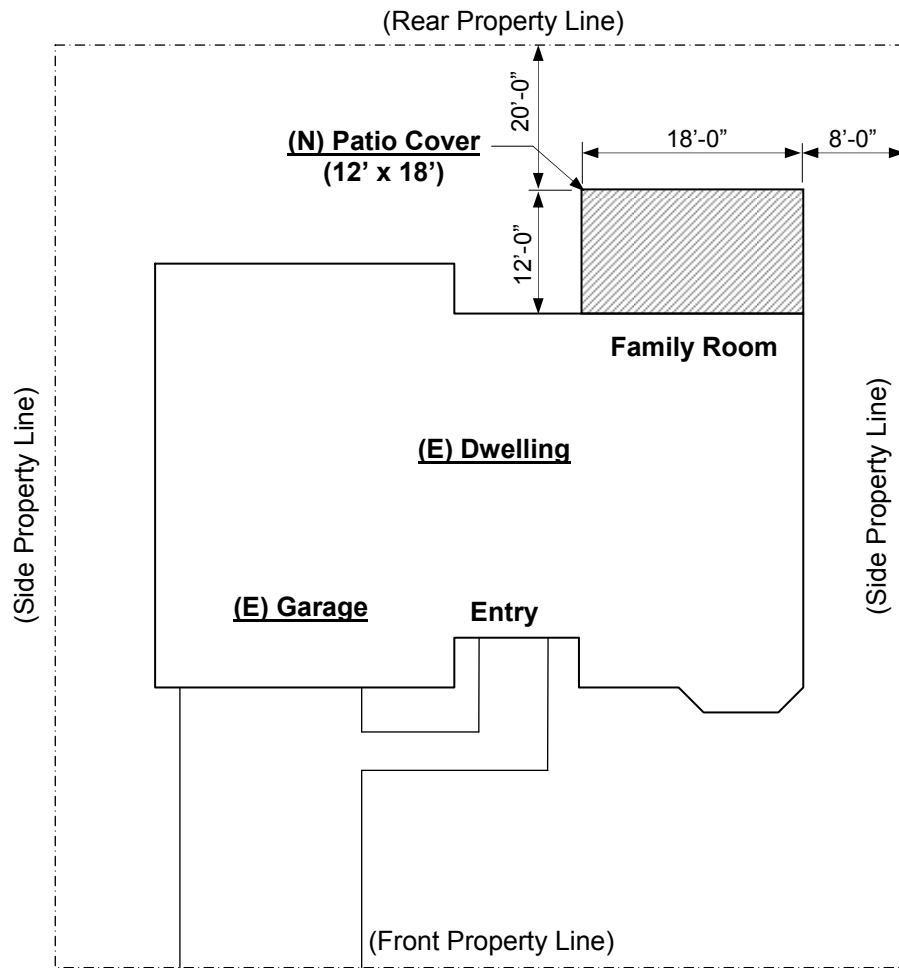

Pleasant Street

Mr. & Mrs. Right  
 100 Pleasant Street, Elk Grove, CA  
 A.P.N. 00-100-2000  
 Scope of Work: New Attached 12'x18' Patio Cover  
 Designed by *Ideal Patios*

**Site Plan**  
 Scale: 1" = 20'-0"

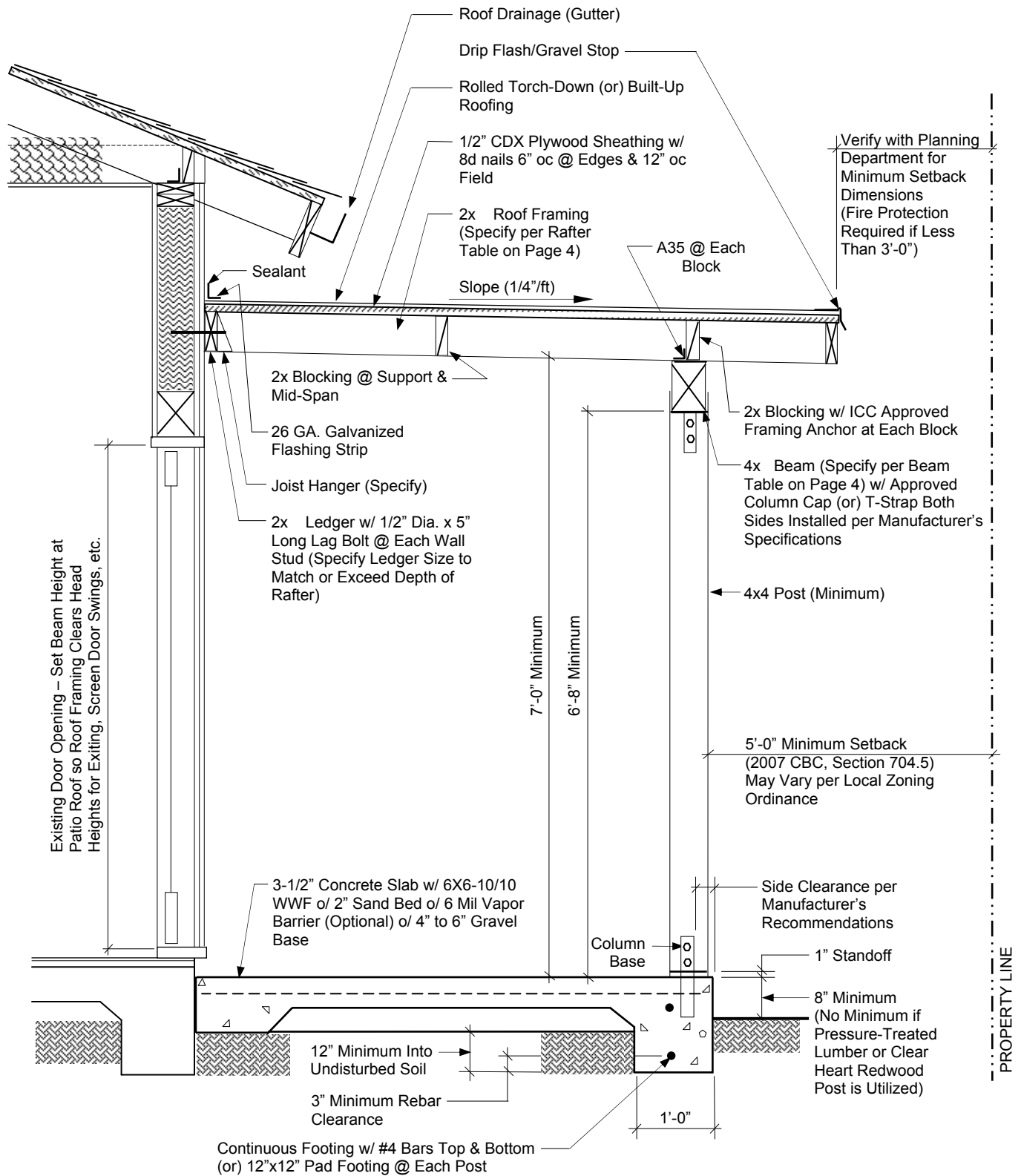

**Cross-Section**  
(Refer to Tables on Page 4 for Member Sizes)

<b>ALLOWABLE SPANS FOR DF #2 ROOF RAFTERS</b>			<b>ALLOWABLE SPANS FOR DF #2 CEILING JOISTS</b>		
Dead Load = 10 psf & Includes Maximum Roofing Material Load = 6 psf (Built-up or Composition Shingle Roofing) Live Load = 20 psf			Dead Load = 10 psf Live Load = 10 psf		
RAFTER SIZE	SPACING	ALLOWABLE SPAN	JOIST SIZE	SPACING	ALLOWABLE SPAN
2x6	24"	10'-6"	2x4	24"	7'-9"
	16"	12'-3"		16"	8'-11"
	12"	13'-6"		12"	9'-10"
2x8	24"	14'-0"	2x6	24"	12'-3"
	16"	16'-0"		16"	14'-9"
	12"	17'-9"		12"	15'-5"
2x10	24"	18'-0"	2x8	24"	15'-9"
	16"	20'-7"		16"	18'-6"
	12"	22'-8"		12"	20'-4"
2x12	24"	21'-4"	2x10	24"	19'-3"
	16"	25'-0"		16"	23'-6"
	12"	27'-7"		12"	26'-0"

Type V construction is a classification of buildings by construction materials and methods. It is the least restrictive permitted by the 2007 California Building Code (CBC) and includes light wood-frame construction. This sheet is for information and reference only and is not a substitute for accurate drawings prepared for each proposed construction project.

<b>ALLOWABLE SPANS FOR BEAMS w/o CEILING</b>	
Based on Maximum Tributary = <b>10'-0"</b> (Span = 20'-0")	
SPAN	BEAM SIZE
Up to 5'-4"	4x4
5'-5" to 7'-9"	4x6
7'-10" to 10'-6"	4x 8
10'-7" to 12'-9"	4x10
11'-10" to 15'-0"	4x12*
*4x12 DF #1 may be used over a 16'-0" garage door in one-story open patio or carport structures.	

<b>ALLOWABLE SPANS FOR BEAMS w/ CEILING</b>	
Based on Maximum Tributary = <b>10'-0"</b> (Span = 20'-0")	
SPAN	BEAM SIZE
Up to 4'-8"	4x4
4'-9" to 6'-10"	4x6
6'-11" to 9'-0"	4x 8
9'-1" to 11'-0"	4x10
11'-1" to 13'-0"	4x12*
*For spans greater than the table values, engineered calculations are required.	

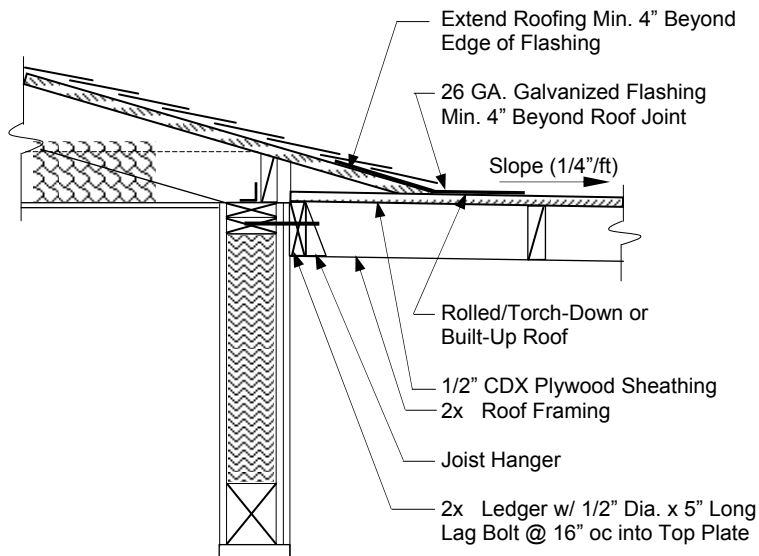

**Alternate Connection Detail**  
(Typical for Patio Covers)

**ALLOWABLE SPANS FOR DF #2 ROOF RAFTERS**

Dead Load = 5 psf & Includes Maximum Roofing Material Load  
 = 2 psf (Light Corrugated/Fiberglass Roofing or Lattice)  
 Live Load = 10 psf

RAFTER SIZE	SPACING	ALLOWABLE SPAN
2x4	24"	8'-6"
	16"	9'-10"
	12"	10'-10"
2x6	24"	13'-6"
	16"	15'-5"
	12"	17'-0"
2x8	24"	17'-9"
	16"	20'-4"
	12"	22'-5"
2x10	24"	22'-8"
	16"	26'-0"
	12"	28'-7"

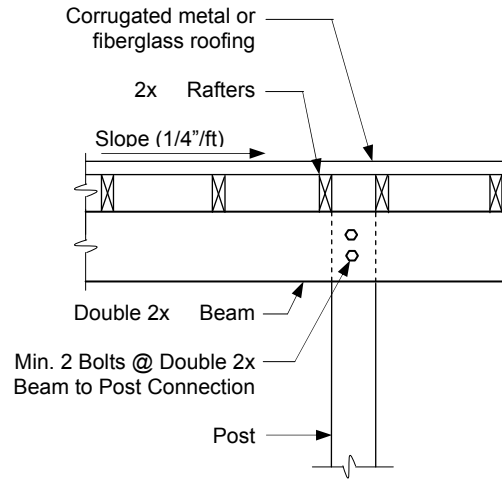

**Patio Cover Detail**  
 (w/ Light Roof Covering)

**ALLOWABLE SPANS FOR DF #1 BEAM**

Based on Maximum Tributary = 10'-0" (Span = 20'-0")

SPAN	BEAM SIZE
Up to 6'-9"	4x4
6'-10" to 10'-0"	4x6
10'-1" to 13'-3"	4x 8
13'-4" to 16'-3"	4x10
11'-1" to 19'-0"	4x12

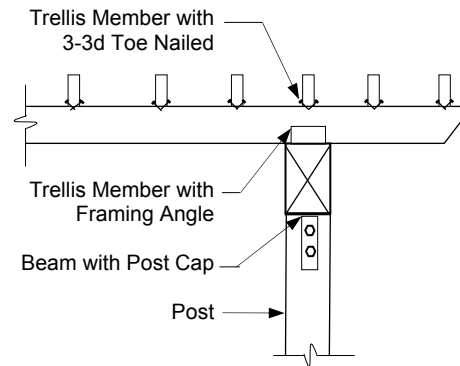

**Trellis Detail**