



Water Heater Installations

February 2005 (Revised February 15, 2011)

Permit Requirements

When do I need a permit?

A water heater (plumbing) permit is always required for new and replacement water heater installations. This allows the Building Safety & Inspection field inspector to ensure safe operation and appropriate strapping.

During emergency situations when a water heater appliance has been installed without first obtaining a permit, it shall be obtained on the next work day following installation. A double fee permit penalty may otherwise be added for doing the work without a permit.

Bracing and Installation

Enforcement

As adopted by the City of Elk Grove, Chapter 5 of the 2010 California Plumbing Code (CPC) enforces the construction, location and installation of fuel burning water heaters.

Location

Water heater installations in bedrooms and bathrooms shall comply with one of the following:

- 1) Fuel-burning water heaters may be installed in a closet located in the bedroom or bathroom provided the closet is provided with a listed, gasketed door assembly and a listed self closing device. All combustion air for such installations shall be obtained from the outdoors. The closet shall be for the exclusive use of the water heater.
- 2) Water heater shall be of the direct vent type.

Protection Bollards

When water heaters are located in the path subject to mechanical damage by vehicles, a suitable barrier shall be installed in front of it.

Strapping

In seismic design categories C,D,E and F water heaters shall be anchored or strapped to resist movement during an earthquake. Straps are to be installed at the upper and lower third (1/3) of the water heater (lower strap 4-in above controls). The straps shall be connected so that the fasteners and straps cannot dislodge or loosen. Refer to page 2 for sample illustrations.

When supported on the ground, water heaters can rest on level concrete or other approved base extending not less than 3-in above adjacent ground level.

Capacity

The minimum capacity for water heaters shall be in accordance with the first hour rating as listed in the table below.

| Table 5-1: Water Heater Minimum Capacity (2010 CPC) ¹ | | | | | | | | | | | |
|--|----------|----|----|----------|----|----|----|----------|----|----|----|
| Number of Bathrooms | 1 to 1.5 | | | 2 to 2.5 | | | | 3 to 3.5 | | | |
| Number of Bedrooms | 1 | 2 | 3 | 2 | 3 | 4 | 5 | 3 | 4 | 5 | 6 |
| First Hour Rating ² (Gallons) | 42 | 54 | 54 | 54 | 67 | 67 | 80 | 67 | 80 | 80 | 80 |

Notes:

- ¹The first hour rating is found on the “Energy Guide” label.
- ²Non-storage and solar water heaters shall be sized to meet the appropriate first hour rating as shown in the table.

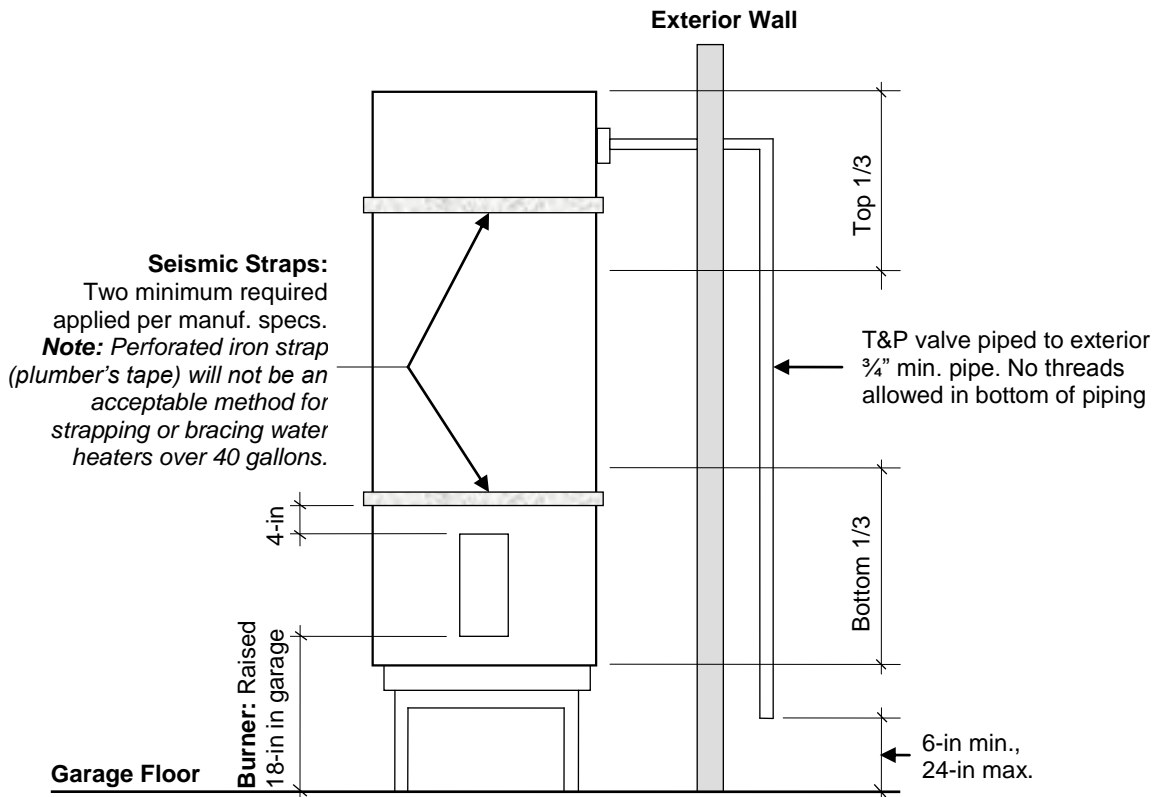

WATER HEATER – ELEVATION

COMBUSTION AIR (2010 CMC, Chapter 7)

Inside Source

Ordinary Construction: Appliance in unconfined space may rely on infiltration alone. Unconfined space is >50 cu. ft./1000 Btu/hr. Appliance may draw air through minimum 100 sq. in. openings into unconfined space, one opening in upper 12-in, one in lower 12-in.

Outside Source

Unusually Tight Construction or Confined Space: Confined space is <50 cu. ft./1000 Btu/hr.

Refer to Table 7-1 for size of combustion air openings or ducts.

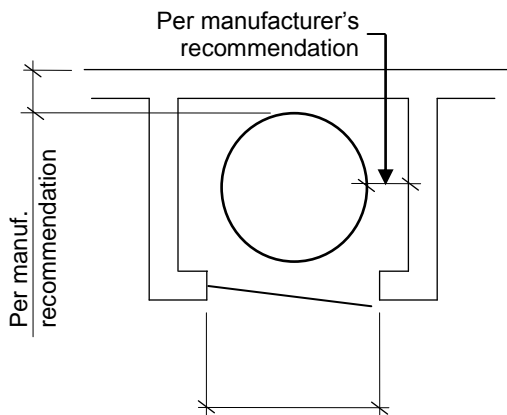

TOP VIEW

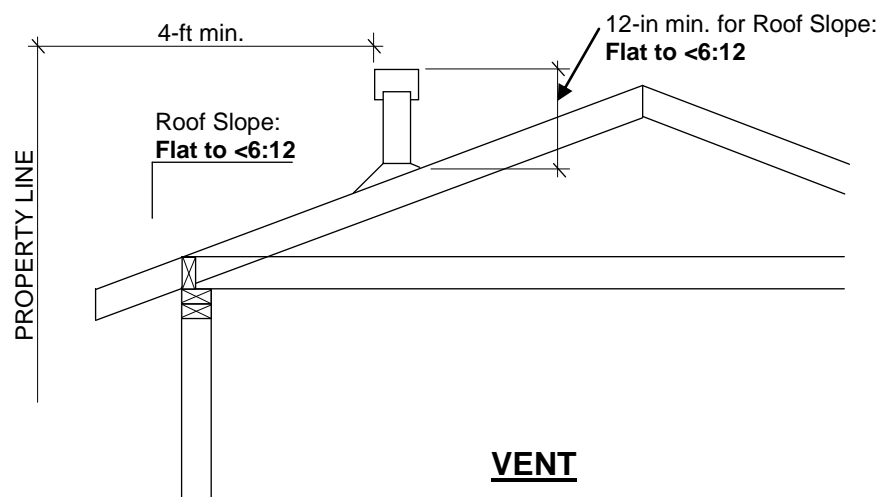

VENT