

KAMMERER ROAD PROJECT



PROJECT PURPOSE

- ➔ Provide greater mobility for residential areas and employment centers along the corridor between State Route 99 and Interstate-5
- ➔ Improve east-west circulation in the City of Elk Grove and south Sacramento County
- ➔ Improve traffic operations and safety within the project area

PROJECT NEED

Provide a missing link in the transportation infrastructure network that serves the City of Elk Grove and south Sacramento County area by:

- ➔ Improving route continuity
- ➔ Reducing travel time and delay
- ➔ Reducing existing and projected traffic congestion in the project corridor and other adjacent transportation corridors
- ➔ Improving traffic safety and operations along project corridor

KAMMERER ROAD PROJECT

ENVIRONMENTAL RESOURCE AREAS



A wide variety of resource areas will be studied during the environmental review to identify potential impacts and subsequent mitigation measures. The environmental factors potentially affected are listed below.

Aesthetics

Agriculture & Forestry Resources

Air Quality

Biological Resources

Cultural Resources

Geology/Soils

Greenhouse Gas Emissions

Hazards & Hazardous Materials

Hydrology/Water Quality

Land Use/Planning

Noise

Population/Housing

Transportation/Traffic

Mandatory Findings of Significance

KAMMERER ROAD PROJECT

ENVIRONMENTAL PROCESS OVERVIEW



Lead agencies must identify and minimize potential significant environmental impacts as well as invite the public to review and participate.

CEQA Lead:
County of Sacramento

NEPA Lead:
California Department of Transportation (Caltrans)

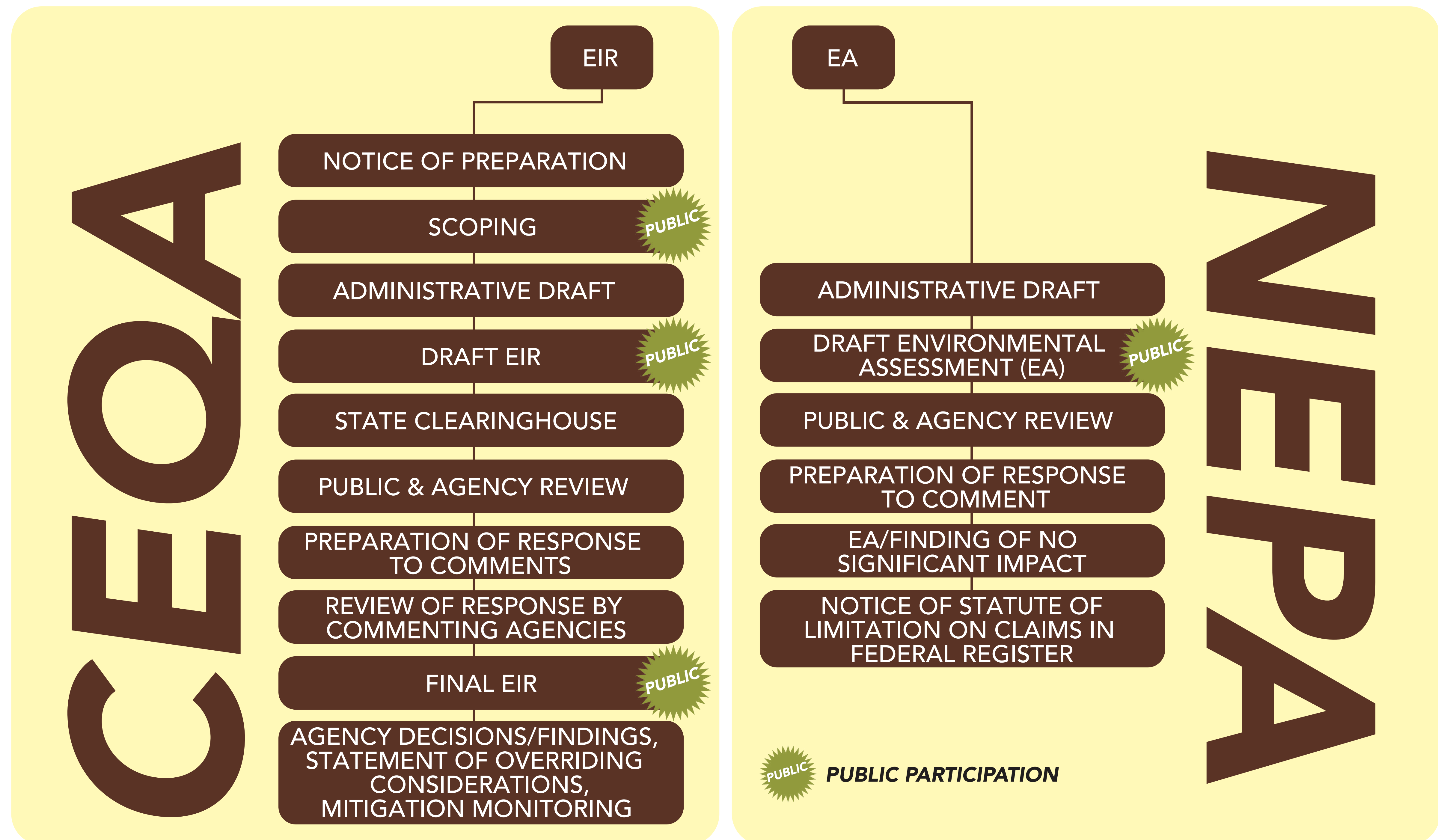

KAMMERER ROAD PROJECT

ALIGNMENT ALTERNATIVES

SACRAMENTO COUNTY

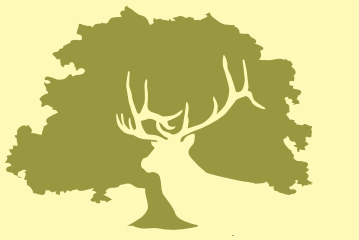

CITY OF ELK GROVE
PROUD HERITAGE. BRIGHT FUTURE.

Proposed North Alignment

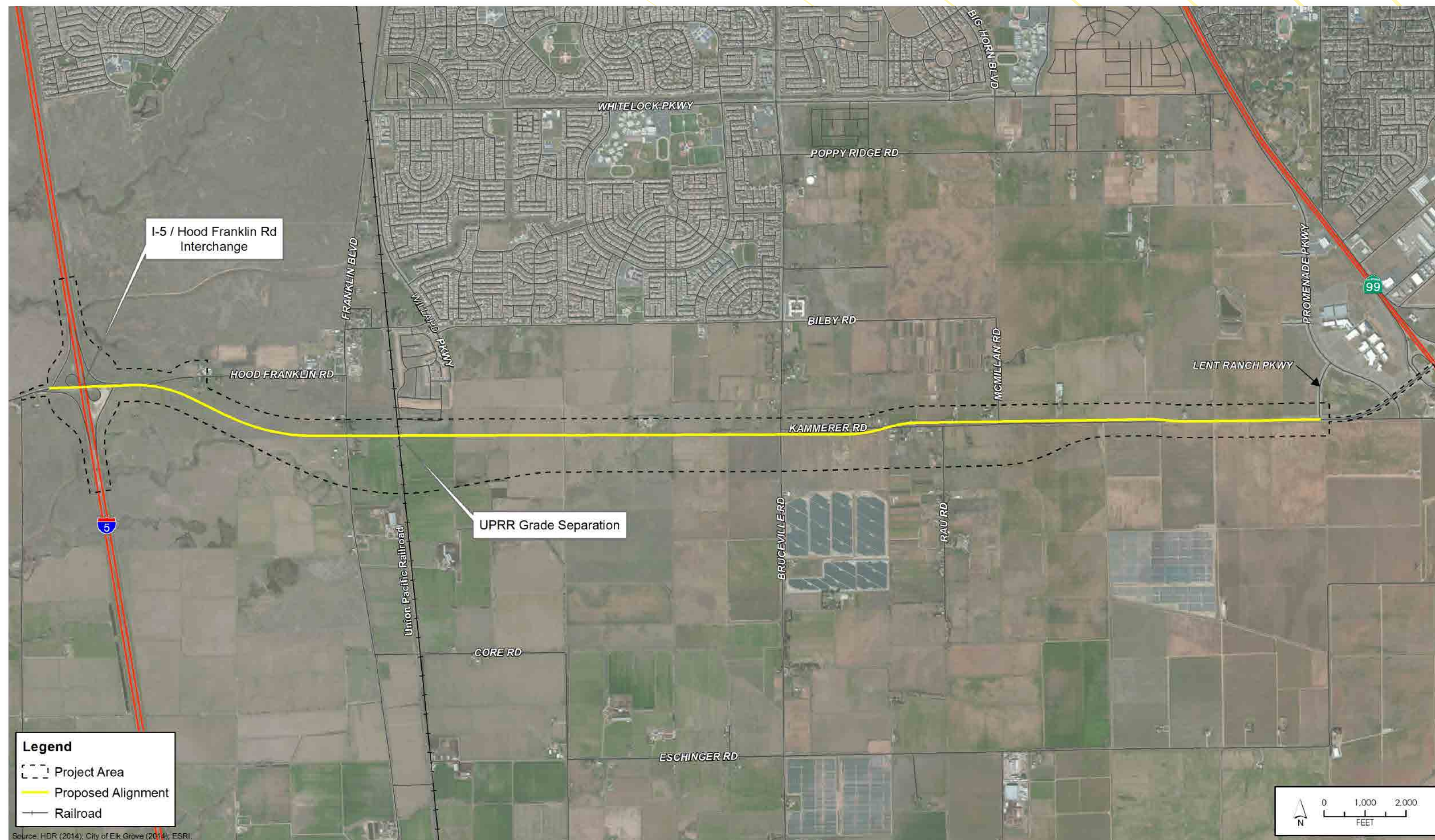

Proposed South Alignment

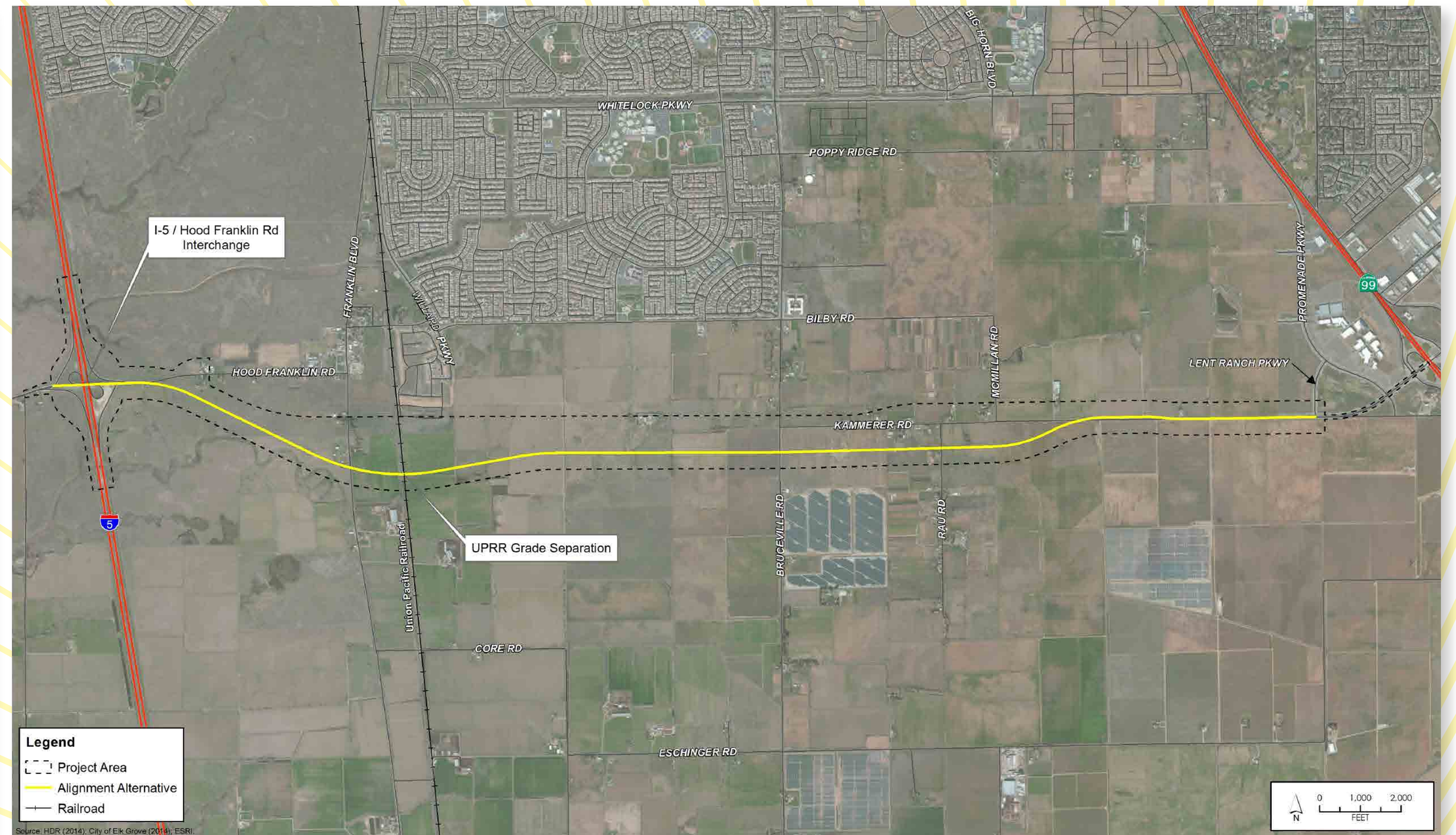

KAMMERER ROAD PROJECT

SACRAMENTO COUNTY



CITY OF ELK GROVE
PROUD HERITAGE. BRIGHT FUTURE.

TYPICAL CROSS SECTIONS

SOUTH SIDE

LOOKING WEST

NORTH SIDE

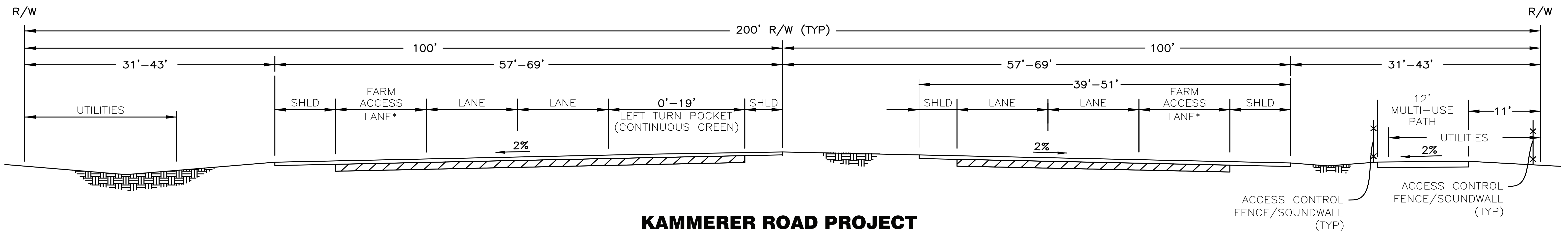

KAMMERER ROAD PROJECT

BETWEEN I-5 AND BRUCEVILLE ROAD
DESIGN SPEED 65 MPH

SOUTH SIDE

LOOKING WEST

NORTH SIDE

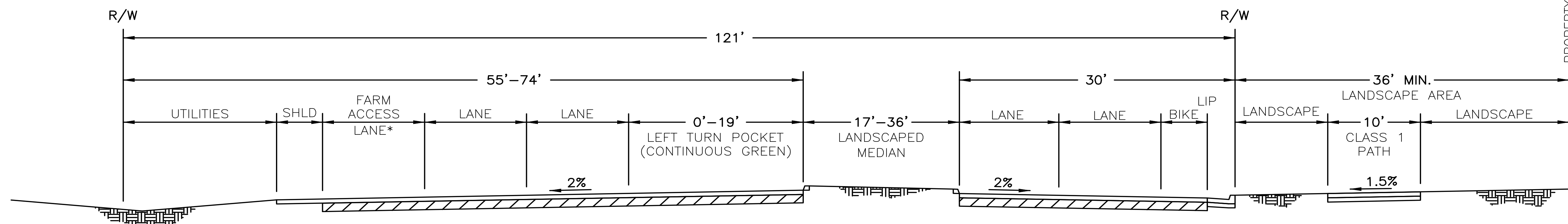

KAMMERER ROAD PROJECT

BETWEEN BRUCEVILLE ROAD AND LENT RANCH PARKWAY
DESIGN SPEED 50 MPH

NOTE:
* RIGHT TURN IN/OUT AT VARIOUS LOCATIONS

KAMMERER ROAD PROJECT

UNION PACIFIC RAILROAD GRADE SEPARATIONS

SACRAMENTO
COUNTY

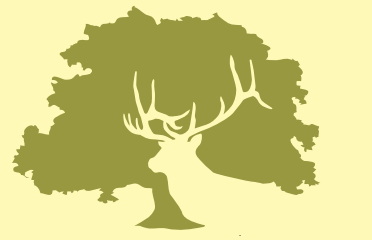

CITY OF
ELK GROVE
PROUD HERITAGE. BRIGHT FUTURE.

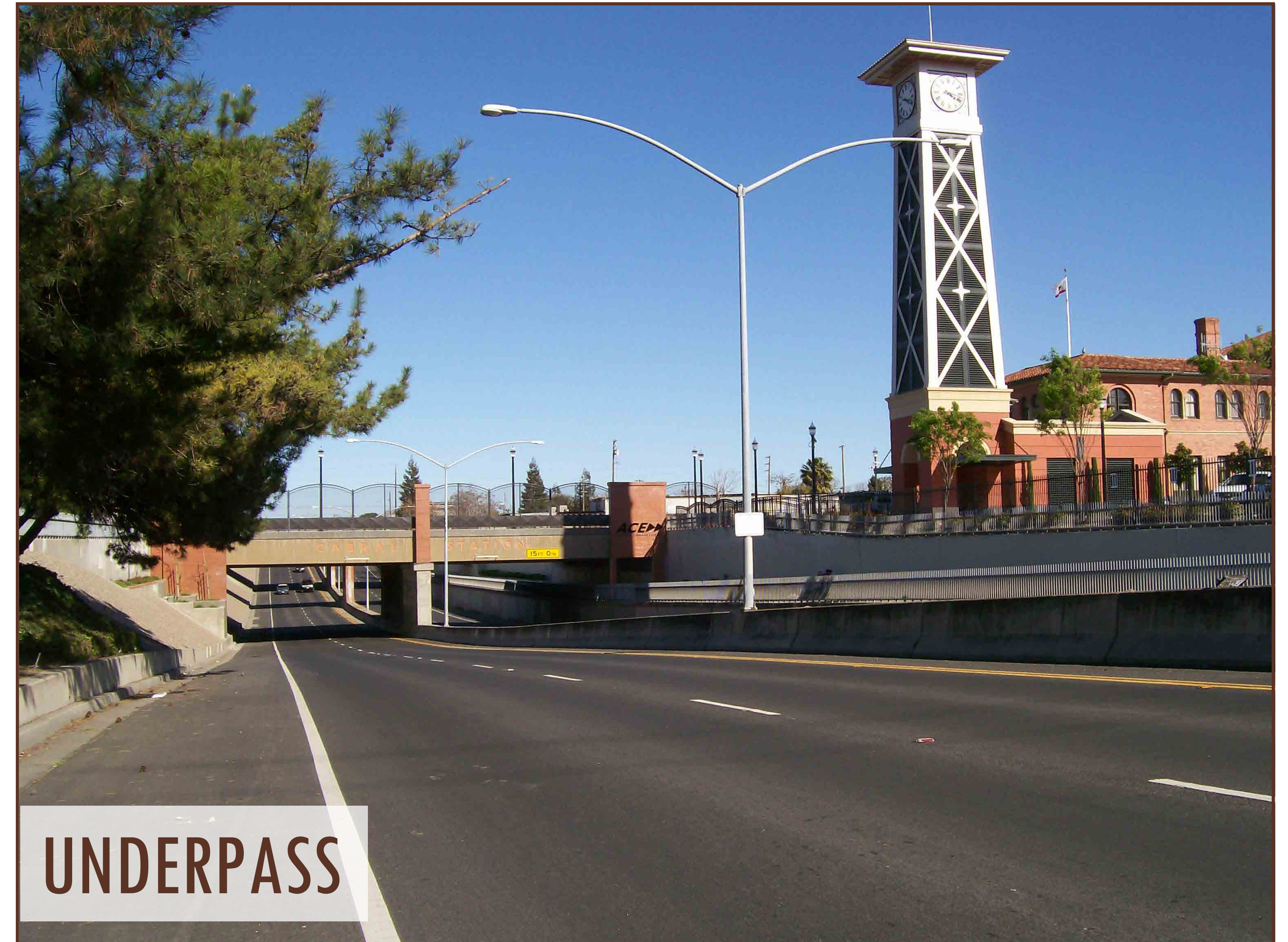

KAMMERER ROAD PROJECT

PROJECT TIMELINE

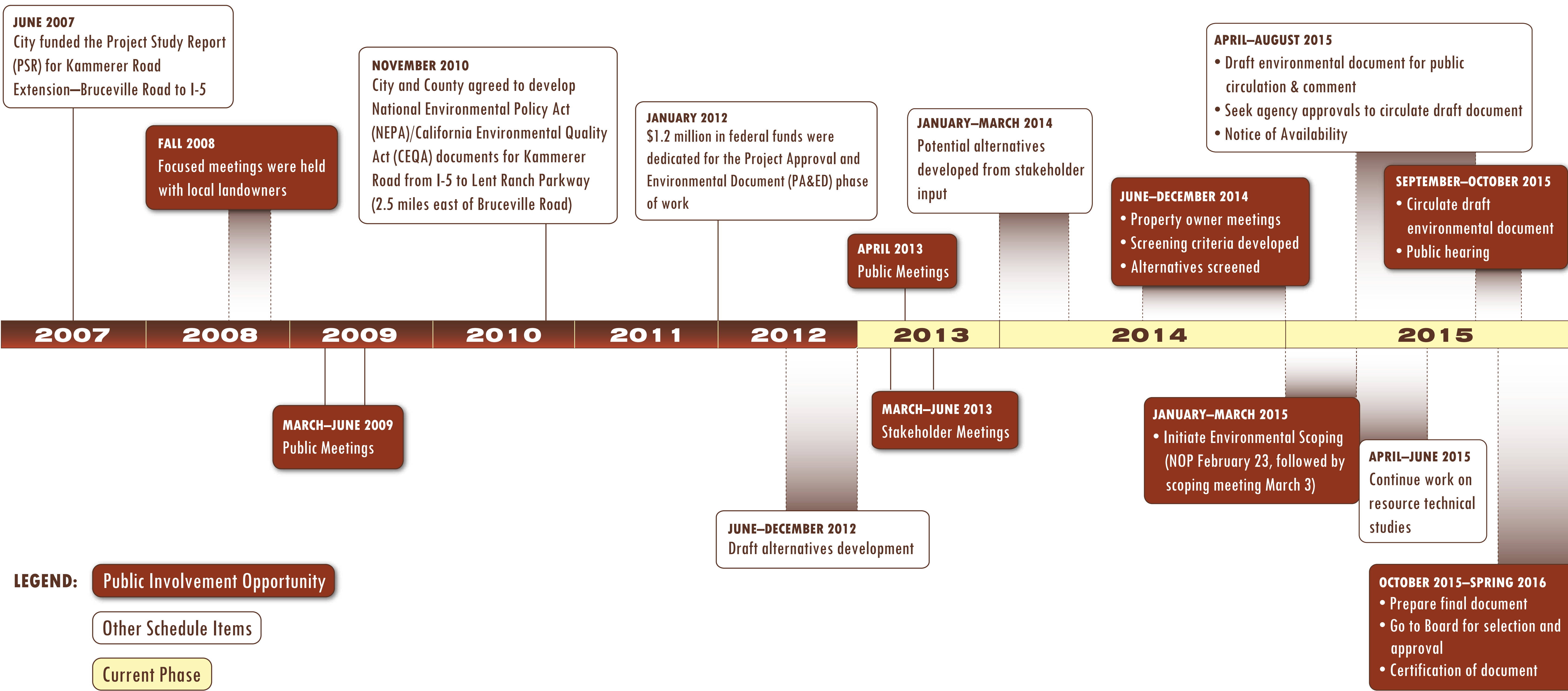

- LEGEND:**
- Public Involvement Opportunity
 - Other Schedule Items
 - Current Phase

KAMMERER ROAD PROJECT

NEXT STEPS



Public participation opportunities during current phase:

- ➔ **Public Scoping Meeting – March 3, 2015**
- ➔ **Draft Environmental Document Public Circulation & Comment Period – Summer 2015**
- ➔ **Public Hearing – Fall 2015**
- ➔ **Certification of Document – Spring 2016**

Design Phase – Pending Funding Availability

Construction Phase – Pending Funding Availability

STAY INVOLVED!

Christopher Jordan, City of Elk Grove Planning Manager

 www.egpublicworks.org/kammerer

 Kammerer.Road@elkgrovecity.org

 **916-478-2222**

KAMMERER ROAD PROJECT

PROJECT FUNDING

Estimated project cost = \$70-80 million (not yet fully funded)

Project funding options:

- City collecting over \$40 million in developer fees
- City anticipating \$40 million in Measure A and federal grant funds

Cash flow issues:

- Get money up front (SACOG approval and possible Transportation Infrastructure Finance and Innovation Act loan)
- “Pay-as-go” using estimated \$5 million per year of funds available to City (federal money & developer fees)
- Other out-of-box solutions

SACRAMENTO
COUNTY



CITY OF
ELK GROVE
PROUD HERITAGE. BRIGHT FUTURE.

KAMMERER ROAD PROJECT

COMMENTS SUBMITTAL

SACRAMENTO
COUNTY



CITY OF
ELK GROVE
PROUD HERITAGE. BRIGHT FUTURE.

Comments and suggestions on the scope and content of the EIR/EA are invited from all interested parties for a period of 30 days, beginning **February 23 until 5:00 p.m. on March 24, 2015.**



**Christopher Jordan, Planning Manager
City of Elk Grove**

8401 Laguna Palms Way | Elk Grove, CA 95758



Kammerer.Road@elkgrovecity.org

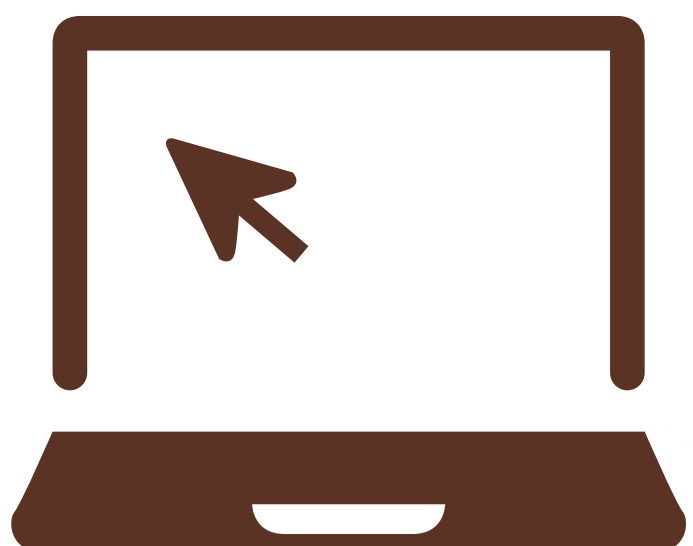

www.egpublicworks.org/kammerer



Christopher Jordan at 916-478-2222



Christopher Jordan at 916-691-3175