

SIGNING AND STRIPING DETAIL
NOT TO SCALE

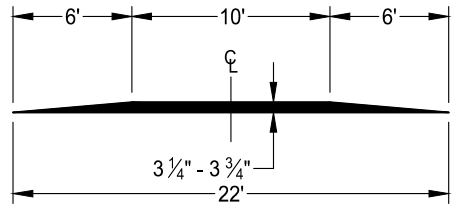

SECTION A-A
NOT TO SCALE

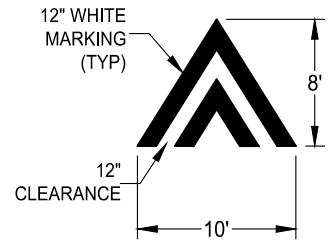

\"/>

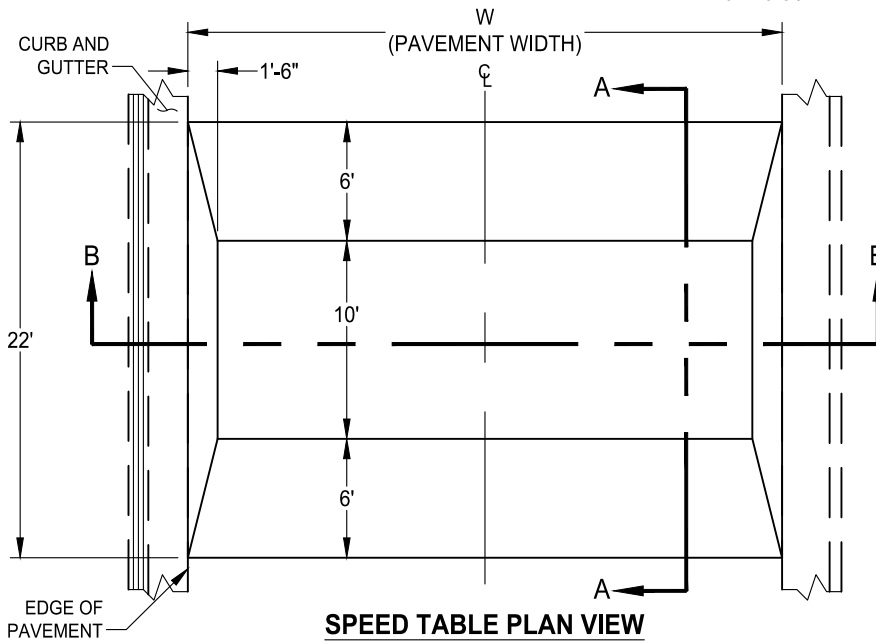

SPEED TABLE PLAN VIEW
NOT TO SCALE

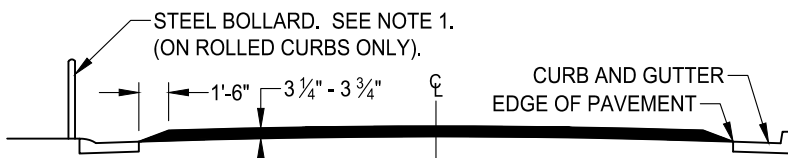

SECTION B-B
NOT TO SCALE

NOTE:

1. INSTALL GALVANIZED STEEL BOLLARD AS NEEDED PER ENGINEER'S DIRECTION OR AS SPECIFIED ON THE PLANS. SEE STANDARD DRAWING NO. T-2A FOR DETAILS.

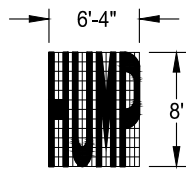

\"/>

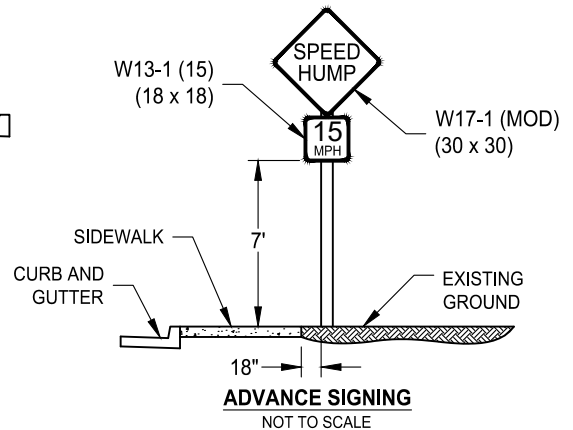

ADVANCE SIGNING
NOT TO SCALE

DATE: 09/22/2017		NOT TO SCALE	
REVISION	BY	APPROVED	DATE

CITY OF ELK GROVE - PUBLIC WORKS

ASPHALT SPEED TABLE DETAIL
(W = 26' - 44')

APPROVED BY:
Paul Mulock
CITY ENGINEER

10/24/2018
DATE

DRAWING NUMBER
T - 2E

