

BASE DETAILS

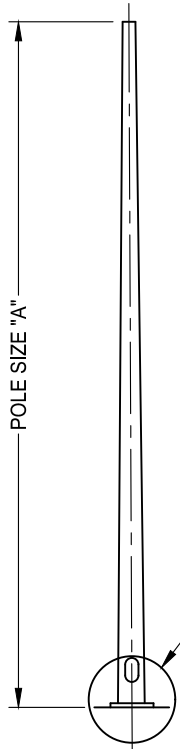

SERIES 'B'

SEE BASE
DETAIL

FOUNDATION DIMENSIONS		
	SQUARE	ROUND
SERIES 'B'	2' x 2' x 4'	2'6" x 3'6" or 2' x 4'

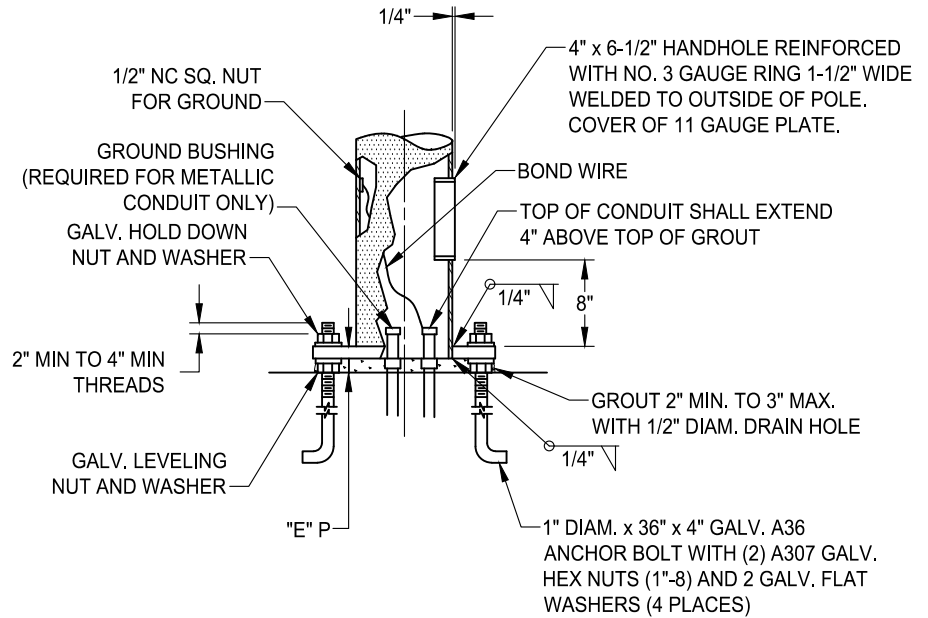

'B' SERIES									
POLE DATA					BASE PLATE DATA				ANCHOR BOLTS
"A"	TOP OD	BASE OD		GAUGE	"B"	"C"	"D"	"E"	
		MIN	MAX						
20'-0"	2-7/8"	5.61"	5.85"	10	10"	9-1/2"	9"	1"	1" x 36" x 4"

NOTES:

- STANDARD SHALL BE INSTALLED SO HANDHOLE FACES THE STREET.
- FOR USE IN ALL IN-FILL PROJECTS EAST OF HIGHWAY 99 OR NORTH OF ELK GROVE BLVD AND WEST OF HIGHWAY 99.

DATE: 09/22/2007		NOT TO SCALE	
REVISION	BY	APPROVED	DATE

CITY OF ELK GROVE - PUBLIC WORKS

**COMMON TYPE ELECTROLIER
(SERIES 'B')**

APPROVED BY:

Paul Mudoch

10/24/2018

CITY ENGINEER

DATE



DRAWING NUMBER

SL - 22