

CHAPTER 3

ENTRY MONUMENTS, WALLS & FENCES

A. CHAPTER OVERVIEW

Entry monuments, community walls, pilasters and fences provide a sense of arrival and establish a distinctive identity for the Plan Area. The overall community design is created and reinforced through repetition of common elements, thematic materials, sizes, textures and colors. Materials include a mix of stone, concrete (cast in place and precast), metal, and wood that are blended together to create a seamless transition between land uses. The design of the entry monuments, community walls, pilaster and fences, and their hierarchy of scales when combined together, invoke a contemporary feeling throughout the Plan Area.

B. GENERAL STANDARDS & REFERENCE ITEMS**1. Materials Standards**

The following is a list of material requirements for all entry monuments, entry monument lettering and logos, walls and fences. Exceptions to the list are as noted:

1. The internal structure of the Entry Monuments, Community Pilasters, and Low Pilasters shall be standard Basalite concrete masonry units ("CMU")*. Contact Basalite at (707) 678-1901 for more information.
2. The Community Wall block shall be Basalite 6" x 8" x 16" Split face CMUs, both sides*. Color shall be #101 (Standard Color). These split face Community Walls shall be constructed using the "Proto II" wall system. Contact Basalite at (707) 678-1901 for more information.
3. Courtyard Wall, Stone Veneer Courtyard Wall, Seatwall and Stone Veneer Seatwall wall block shall be standard Basalite 6" x 8" x 16" CMUs*. Contact Basalite at (707) 678-1901 for more information.
4. Open View Fence with Low Wall block shall be Basalite 8" x 8" x 16" Split face CMUs, both sides*, to accommodate fence posts. Color shall be #101 (Standard Color). Contact Basalite at (707) 678-1901 for more information.
5. The stone veneer shall be a manufactured stone, El Dorado Stone Sanibel Coastal Reef*. Stone shall be a drystack pattern with minimal to no joints between stones. Stone shall be located on all sides of each entry monument. Stone end pieces shall be used at all wall 90 degree corners. The protrusion of the stone veneer shall be flush with the bottom width of the pilaster cap or wall cap. All stone veneer shall receive two coats of El Dorado Stone Craftshield Manufactured Stone Veneer Protective Product*. Contact El Dorado Stone at (800) 925-1491 for more information.
6. The Entry Monuments, Community Pilaster, and Low Pilaster pilaster cap shall be a Handalstone custom precast concrete cap*. Profile to match PC5. Color: Harvest (73). Texture: Stone Travertine (4). Contact Handalstone at (916) 386-1430 for more information. Specific cap information is as follows:
 - Primary Entry Monument: Bottom width 6'-1" x 5'-1", overall width 6'-5" x 5'-5", height 9". The pilaster cap shall be constructed in four equal pieces and mortared together on site to create one continuous cap.
 - Secondary Entry Monument, Neighborhood Entry Monuments #1 & #2, and Employment Area Entry Monuments: Bottom width 5'-1" x 4'-1", overall width 5'-5" x 4'-5", height 9". The pilaster cap shall be constructed in four equal pieces and mortared together on site to create one continuous cap.
 - Neighborhood Entry Monuments #3 & #4: Bottom width 4'-1" x 3'-1", overall width 4'-5" x 3'-5", height 9". The pilaster cap shall be constructed in four equal pieces and mortared together on site to create one continuous cap.
 - Community and Low Pilasters: Standard bottom width 28", overall width 31", height 6-1/2".
7. The Primary Entry Monument, Secondary Entry Monument, Neighborhood Entry Monuments #1, #2 and #3, Community Wall, Courtyard Wall, Stone Veneer Courtyard Wall, Seatwall, and Stone Veneer Seatwall wall cap shall be a custom precast concrete wall cap. Profile to match Handalstone PC5*, unless otherwise noted. Color:

*=Or approved equivalent

Harvest (73). Texture: Stone Travertine (4)*. Each wall cap is 24" long. A wall end cap piece shall be used at the terminus of the wall (if it does not terminate at a pilaster). Contact Handalstone at (916) 386-1430 for more information. Specific wall cap information is as follows:

- Primary and Secondary Entry Monument: Bottom width 21", overall width 24", height 6-1/2".
 - Neighborhood Entry Monuments #1 & #2: Bottom width 13", overall width 15", height 4".
 - Neighborhood Entry Monument #3: Bottom width 12", overall width 14", height 2-3/4". Wall cap shall be flat without any peak to provide a flat surface for the metal grid panel.
 - Community Wall and Open View Fence with Low Wall: Bottom width 9", overall width 12", height 6-1/2". All concrete wall caps to be used on Community Walls shall have a void in the bottom of the cap to accommodate for the "Proto II" wall system's tensioning hardware.
 - Courtyard Wall: Bottom width 10", overall width 12", height 4".
 - Stone Veneer Courtyard Wall: Bottom width 11", overall width 13", height 4".
 - Seatwall: Bottom width 10", overall width 12", height 2-3/4". All Seatwall caps shall be flat without any peak to allow pedestrians to sit on cap.
 - Stone Veneer Seatwall: Bottom width 11", overall width 13", height 2-3/4". All seatwall caps shall be flat without any peak to allow pedestrians to sit on cap.
8. Open View Fence with Low Wall wall cap shall be a standard precast concrete wall cap. Profile to match Handalstone WC515*. Color: Harvest (73). Texture: Stone Travertine (4)*. Each wall cap is 24" long. Contact Handalstone at (916) 386-1430 for more information.
9. The Community Wall and Open View Fence with Low Wall CMU block mortar shall be Basalite Amerimix "Type S" mortar. Color: 381*. Contact Basalite at (707) 678-1901 for more information.
10. The stone veneer mortar shall be Orco Blended Products Poly VBM 300, Veneer Bonding Mortar* - Poly Modified Mortar and shall be selected for use on vertical surfaces. Color: Surf. Contact Orco Blended Products at (951) 818-4054 for more information.
11. Pilaster and wall caps shall be attached with Orco Blended Products R-Lastic waterproof elastomeric coating* and VBM Bonder polymer modified thin set*. Color: Pearl*. Finish with Orco Blended Products VP Joint Grout premium sand grout with polymer. Color: Pearl. Contact Orco Blended Products at (951) 818-4054 for more information.
12. The Courtyard Wall and Seatwall stucco shall have a "Fine" Stucco finish, 1" thick Omegaflex 3-coat stucco system*. Process shall include base coat, primer coat, and finish coat per manufacturer's specifications and details. All CMU joints and any imperfections shall not be visible through finish coat. Stucco shall be flush with bottom width of wall cap. Prime and paint with two (2) coats of exterior latex paint, color to match or compliment adjoining/adjacent building color. Contact Silverado Building Materials (916) 361-7374 for more information.
13. The Primary Entry Monument, Secondary Entry Monument, and Neighborhood Entry Monuments #1, #2 & #4 metal wrap-around panels shall be a 1" thick panel, with a 3-1/2" high by 2" wide lip all sides which abuts the stone veneer. The metal wrap-around panel shall be attached directly to the block wall and shall wrap around the block wall and terminate on the back side of the wall. The metal wrap-around panel shall be one continuous piece of metal to prevent gaps as it wraps around the wall. Specific conditions apply to the Neighborhood Entry monuments:

* = Or approved equivalent

CHAPTER 3

ENTRY MONUMENTS, WALLS & FENCES: GENERAL STANDARDS & REFERENCE ITEMS

- Neighborhood Entry Monuments #1, #2 & #4: The lettering side of the metal panel shall be located on the front of the pilaster which faces the intersection into the community. The logo side of the metal pilaster shall be located on the side of the pilaster and face the street.
14. The Primary Entry Monument, Secondary Entry Monument and Neighborhood Entry Monument #3 metal medallions shall be a 1" thick panel, with a 3-1/2" high by 2" wide lip all sides which abuts the stone veneer. The metal medallion shall be attached directly to the block wall, and shall be one continuous piece of metal to prevent gaps. The logo side of the metal medallion shall face the intersection to the community. The metal medallion's materials, powder coat color, and top coat shall match those used on the metal wrap-around panel.
15. Neighborhood Entry Monuments #1, #2, #3 and Employment Area Entry Monuments shall include a metal grid panel. The metal grid panel is broken down into three major elements: (1) the 3" outer frame assembly, (2) the grid section and (3) the tubular steel mounting brackets attaching the panel to the pilaster. The outer frame assembly of the grid panel shall be 1/4" x 3" x 3" steel angle L channels, mitered all corners. The L channel outer frame assembly creates the exterior framing for the grid section. The metal grid section shall be constructed using 1" wide x 4" high x 1" deep grids with 1" wire U edging on all side mitered at corners. Refer to the images on the opposing page for more information regarding the design of the metal grid panel. Specific metal grid panel information as follows:
- Neighborhood Entry Monuments #1, #2 & #3: The metal grid sections and L channel outer frame assembly shall be attached together using hex bolts, or similar attachment. Because these Neighborhood Entry Monuments can be seen when entering and existing the neighborhood, an identical metal grid section with L channel outer frame assembly shall be mirrored facing the other direction. Both structures shall be welded together to create one solid metal grid panel that is 6" in width at the outer frame assembly. The outer frame assembly shall sit 1" off the top of wall cap.



**Example of L Channel
Outer Frame at corner**



**Example of Metal Grid Panel
Mounting Bracket, when
applicable** (Metal Frame to Pilaster)



**Example of Hex Bolt
Attachment/Accent**
(Metal Grid Panel to Frame)



**Example of Metal Grid
Section**



**Example of L Channel Outer
Frame and Metal Grid Interface**



**Example of Metal
Grid Panel** (Overall)

The solid metal structure is attached to the Neighborhood Entry Monument pilasters in slightly different ways:

- Neighborhood Entry Monuments #1 & #2: Multiple 1" x 3" tubular steel mounting brackets attached to pilaster's block wall internal structure with steel mounting plates and concrete anchor bolts, or as required by the structural engineer.
 - Neighborhood Entry Monument #3: Attachment as required by the structural engineer.
 - Employment Area Entry Monument: Four grid sections are required for this monument (each visible side). The metal grid sections and L channel outer frame assembly shall be welded together in the interior of the metal structure, or similar attachment. This structure is entirely welded together, not bolted. However, hex bolts may be located on the grid panel as accents. Additionally, a 3" deep arched metal cap shall be welded to the top of the metal grid panel. Finally, a solid sheet metal accent panel shall be located at the bottom of the metal grid panel. Once together, the metal grid panel shall be attached to the pilaster as required by the structural engineer. Because the Employment Area Entry Monument is a stand-alone monument that will be seen from all four sides, the interior of the metal grid panel shall be internally illuminated and/or internally up-lighted. Due to the interior lighting within the metal grid panel, access should be provided within the metal structure for maintenance of all lighting.
16. When an Entry Monument's metal panel, wrap-around panel, medallion, and/or grid panel are featured on an entry monument, it/they shall be powder coated with the color Copper (Stellix 49/90620)*, unless otherwise noted, and finished with a clear top coat as available from Tiger Drylac USA*, contact (800) 243-8148 for more information.
 17. The Employment Area Entry Monument metal grid panel, arched metal cap, and metal accent panel shall be powder coated with either the color Copper (Stellix 49/90620)* or Standard Silver (Stellix 49/90380)*.
 18. All wood fencing throughout the Plan Area shall be Cedar and shall receive a minimum two coats of semi transparent stain, Mushroom #910 by Olympic Stain*.
 19. Open View Fence and Open View Fence with Low Wall shall be constructed out of square tubular steel, welded together to create a consistent view fence. Fence shall receive two coats of painted black finish. Fence shall be 6' tall (may be shorter with approval from the City).
 20. Tubular Steel Fence with Accents shall be constructed out of square tubular steel and accented with circular steel, welded together to create a consistent decorative fence. Fence shall receive two coats of painted black finish. Fence shall be 42" high (may be shorter with approval from the City).
 21. All Split Rail Fences shall be Artisan Precast Woodcrete* two rail precast split rail concrete fence. Color: Sandstone (Standard Color)*. The design shall be reminiscent of a traditional farm fence. Fence post style shall vary based on the following conditions: (1) line post for standard runs of fencing, (2) end posts at the terminus of fencing, and (3) corner posts at corners and significant changes of direction of fencing. Split Rail Fence shall be 3' tall. Posts shall be located 8' on center and at any changes of direction. Contact Artisan Precast at (800) 511-2747 for more information.
 22. Post and cable fence shall be constructed and installed per City of Elk Grove Standard Detail L-20, latest version.

* = Or approved equivalent

2. General Landscaping Standards

The following is a list of general landscaping requirements for all entry monuments, walls & fences. Exceptions to the list are as noted:

1. Enriched landscaping is required at all entry monument locations. One-hundred percent (100%) of all shrubs shall be 5-gallon in size. Plants that are not commercially available in a 5-gallon size, may be substituted for a 1-gallon size. (Refer to Chapter 6)
2. All groundcover at Primary, Secondary, and Neighborhood Entry Monuments #1 & #2 shall be 1-gallon minimum. Groundcover shall be located a maximum of 3' on center spacing. (Refer to Chapter 6)
3. Street Trees as required along specific street. Refer to Chapter 2 to reference specific street. Refer to General Landscape Plant Palette and Major Streetscape Street Tree List, Chapter 6.
4. Primary and Secondary Entry Monument Specimen Trees - six total per corner, three (3) each side of monument (48" box). Refer to Primary and Secondary Monument Plan - Enlargements and Chapter 6 for more information.
5. Primary Entry Monument Major Accent Trees - three (3) behind primary monument (48" box). Refer to Primary Monument Plan - Enlargement and Chapter 6 for more information.
6. Neighborhood Entry Monument #1 & #2 Specimen Trees - two total per monument, one (1) each side of metal grid panel (36" box). Refer to Neighborhood Entry Monument #1 & #2 Plan - Enlargements and Chapter 6 for more information.
7. When any of the following elements are featured on Primary, Secondary, and Neighborhood Entry Monuments, it/they shall be up-lighted with vandal-proof, ground-mounted lighting fixtures and shall not be box or back lighted, unless otherwise noted:
 - Lettering
 - Logo
 - Medallion
8. Employment Area Entry Monuments shall be lighted per City requirements.
9. Landscape lighting is not required throughout the Plan Area. If landscape lighting is proposed in publicly maintained areas, it shall be a vandal-proof fixture as approved by the City.

3. Lettering & Logo Standards

a. Lettering & Logo Materials Standards

The following is a list of lettering and logo material requirements for all Entry Monuments. Exceptions to the list are as noted:

1. All Entry Monument's lettering and logos shall be laser cut aluminum with an acrylic paint finish and shall be attached to the CMU block wall through the metal panel, metal wrap-around panel, and/or medallion, unless otherwise noted. The letter and logos shall be surfaced mounted, and held a minimum of 1/2" off of the face of the metal panel to provide visual relief and shadow. Lettering shall be individual lettering, not continuous, and shall be independent of metal panel, metal wrap-around panel, and medallion. Refer to Lettering and Logo Standards section of this chapter for more information.
2. The Entry Monument's lettering and, when applicable, logo shall receive one coat of Pro Industrial Pro-Cryl Universal Acrylic Primer* applied per the manufacturer's specifications. Following the coat of primer, 2 coats of Pro-Industrial DTM Acrylic Coating* shall be applied per the manufacturer's specifications, color shall be Navajo White (SW6126)*, unless otherwise noted. Available from Sherwin Williams, contact (800) 524-5979 for more information.
 - The Employment Area Entry Monument lettering's color shall vary based on the color of the metal grid panel: 1) If the metal grid panel's color is Copper, then the lettering's color shall be Navajo White (SW6126)*, or 2) If the metal grid panel's color is Standard Silver, then the lettering's color shall be Black of Night (SW6993)*.
3. Employment Area Entry Monument's tenant sign lettering panel shall be attached to an internally illuminated box that wraps around two sides of the pilaster. Each tenant sign on the street side of the monument ("primary panel") shall be composed of two layers ("facade" and "sub-layer"). The tenant sign lettering facade layer shall be a computer cut, acrylic-painted aluminum panel with an acrylic panel sub-layer behind to provide contrast and relief, as well as back lighting. See the images below for examples of internally illuminated lettering. The primary panel facade layer's font/lettering shall match the letter branding/font requirements of each tenant. The primary panel facade layer's color shall match the metal grid panel. A colorful acrylic sub-layer shall contrast the facade lettering panel. The lettering on the driveway side of the monument ("secondary panel") shall be a solid, acrylic-painted aluminum panel without any lettering. The secondary panel's color shall be identical to the color of the primary panel facade layer. Both the primary and secondary panels shall be constructed and installed so that they can be easily removed, maintained, and replaced when necessary. The City shall approve the exact materials used to create all panels and the internally illuminated box.



Example of Internally Illuminated Lettering (Facade and Sub-Layer)

(typ. of 2)

*=Or approved equivalent

CHAPTER 3

ENTRY MONUMENTS, WALLS & FENCES: GENERAL STANDARDS & REFERENCE ITEMS

The following text and images describe and illustrate the lettering and logo requirements for all Entry Monuments.

4. The metal lettering and logo content for all Entry Monuments shall be approved by the City prior to installation.
5. Developers shall provide one complete spare set of letters to the City Operations & Maintenance Division for each monument constructed.
6. The lettering font shall be Helvetica 55 Roman for the first word and Helvetica 45 Light for the second word.
7. Lettering and logo requirements are listed below. Refer to the following pages for images of the lettering and logo requirements for the individual Entry Monuments:
 - Primary and Secondary Entry Monument:
 - a. Each letter shall be approximately 15" in height and shall be approximately 3" thick.
 - b. The logo shall be approximately 18" in height and shall be approximately 3" thick.
 - Primary Entry Monument: The Primary Entry Monument logo's content shall be used on all Primary Entry Monuments.
 - Secondary Entry Monument: The Secondary Entry Monument logo's content shall be used on all Secondary Entry Monuments.
 - Neighborhood Entry Monuments #1, #2 & #4:
 - a. The size of each letter shall be determined by the final verbiage provided by the Residential Unit Builder, but is required to be 6" at minimum. Each letter shall be approximately 2" thick.
 - b. The logo shall be approximately 12" in height and shall be approximately 2" thick.
 - Neighborhood Entry #3 Monument:
 - a. The size of each letter shall be determined by the final verbiage provided by the Residential Unit Builder, but is required to be 6" at minimum. Each letter shall be approximately 2" thick.
 - Employment Area Entry Monument:
 - a. The size of each vertical letter shall be determined by the final verbiage provided by the land owner/developer, but shall be approximately 9" in height and shall be approximately 1" thick. Lettering shall be located on two sides of the monument.
 - b. The logo shall be approximately 12-18" in height and shall be approximately 1" thick and located on two sides of the monument.

b. Primary & Secondary Entry Monuments

Refer to Lettering & Logo Material Standards on Page 3-8 and Lettering & Logo Standards on Page 3-9

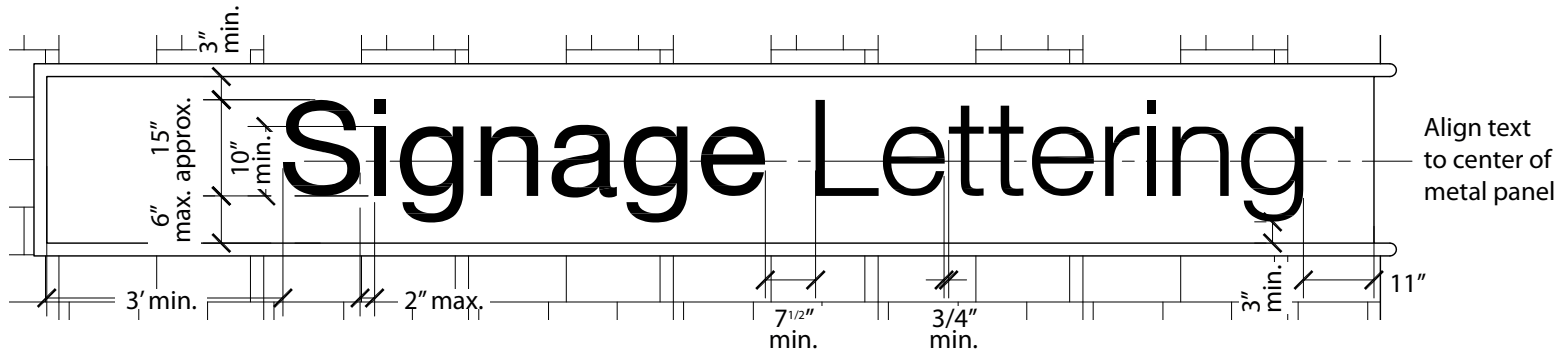

Primary Monument Lettering Requirements - Not to Scale

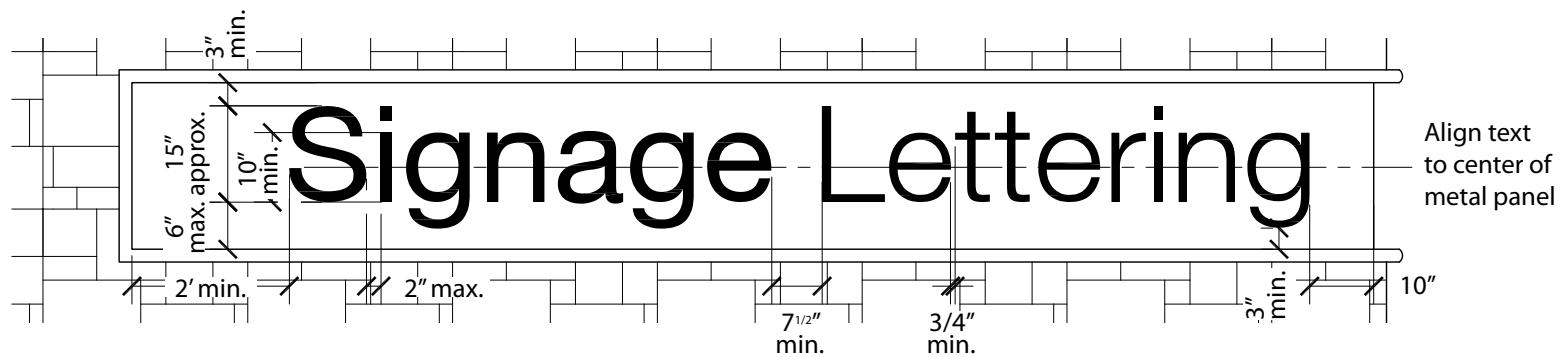

Secondary Monument Lettering Requirements - Not to Scale

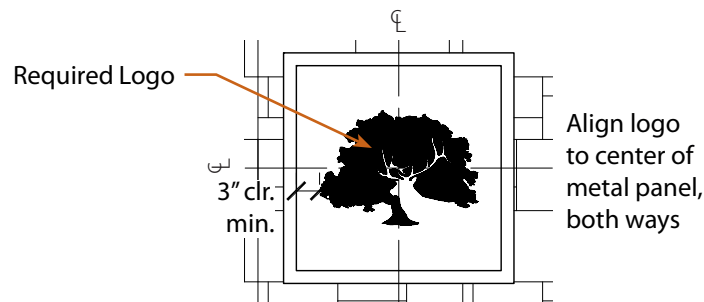

Primary & Secondary Monument Logo Requirements - Not to Scale

CHAPTER 3

ENTRY MONUMENTS, WALLS & FENCES: GENERAL STANDARDS & REFERENCE ITEMS

c. Neighborhood Entry Monuments

Refer to Lettering & Logo Material Standards on Page 3-8 and Lettering & Logo Standards on Page 3-9

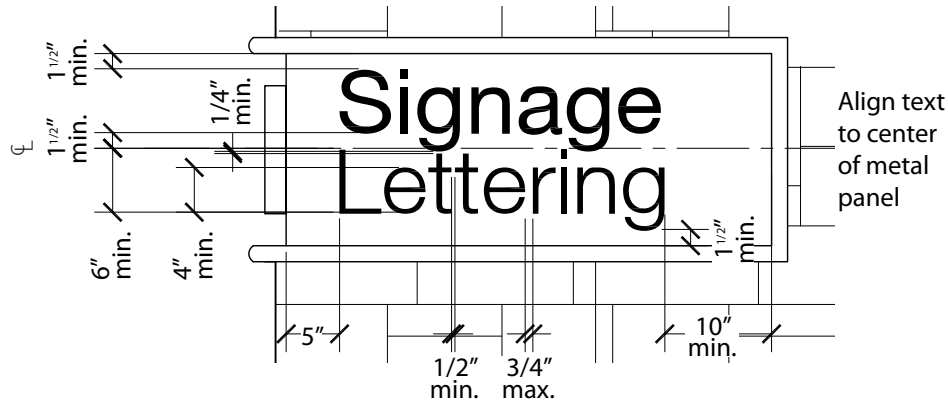

Neighborhood Entry Monument #1 & #2 Lettering Requirements -
Not to Scale

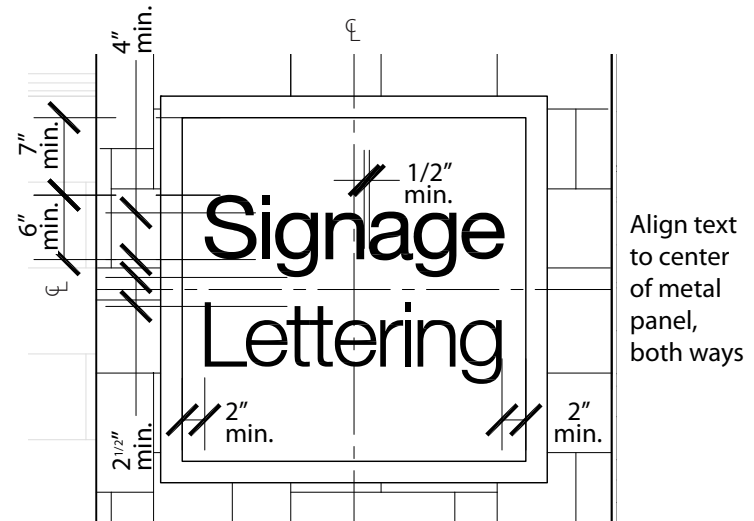

Neighborhood Entry Monument #3 Lettering Requirements - Not to Scale

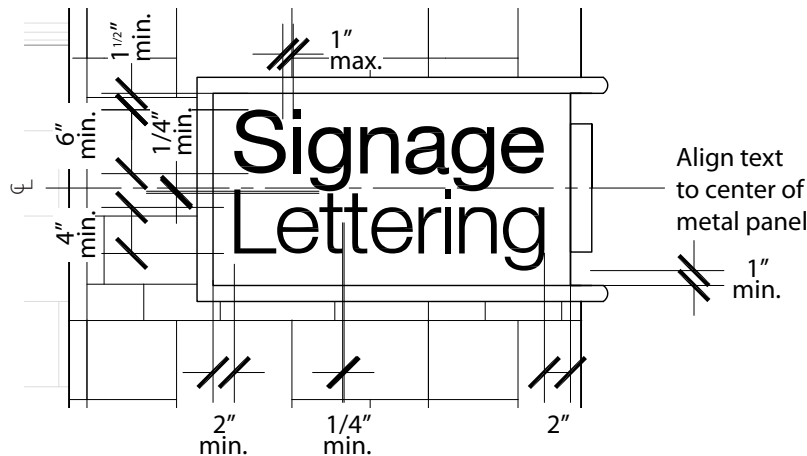

Neighborhood Entry Monument #4 Lettering Requirements -
Not to Scale

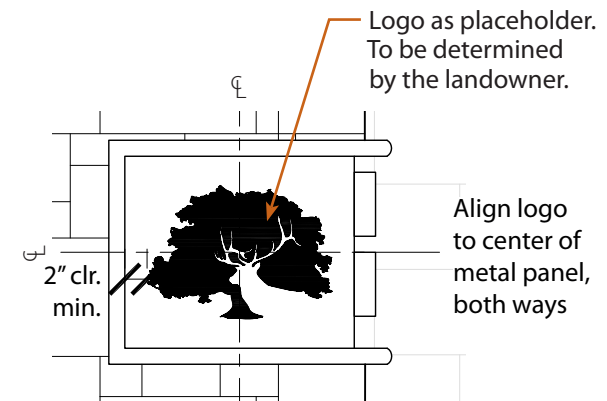

Neighborhood Entry Monument #1, #2 & #4 Logo Requirements - Not to Scale

d. Employment Area Entry Monuments

Refer to Lettering & Logo Material Standards on Page 3-9 and Lettering & Logo Standards on Page 3-10

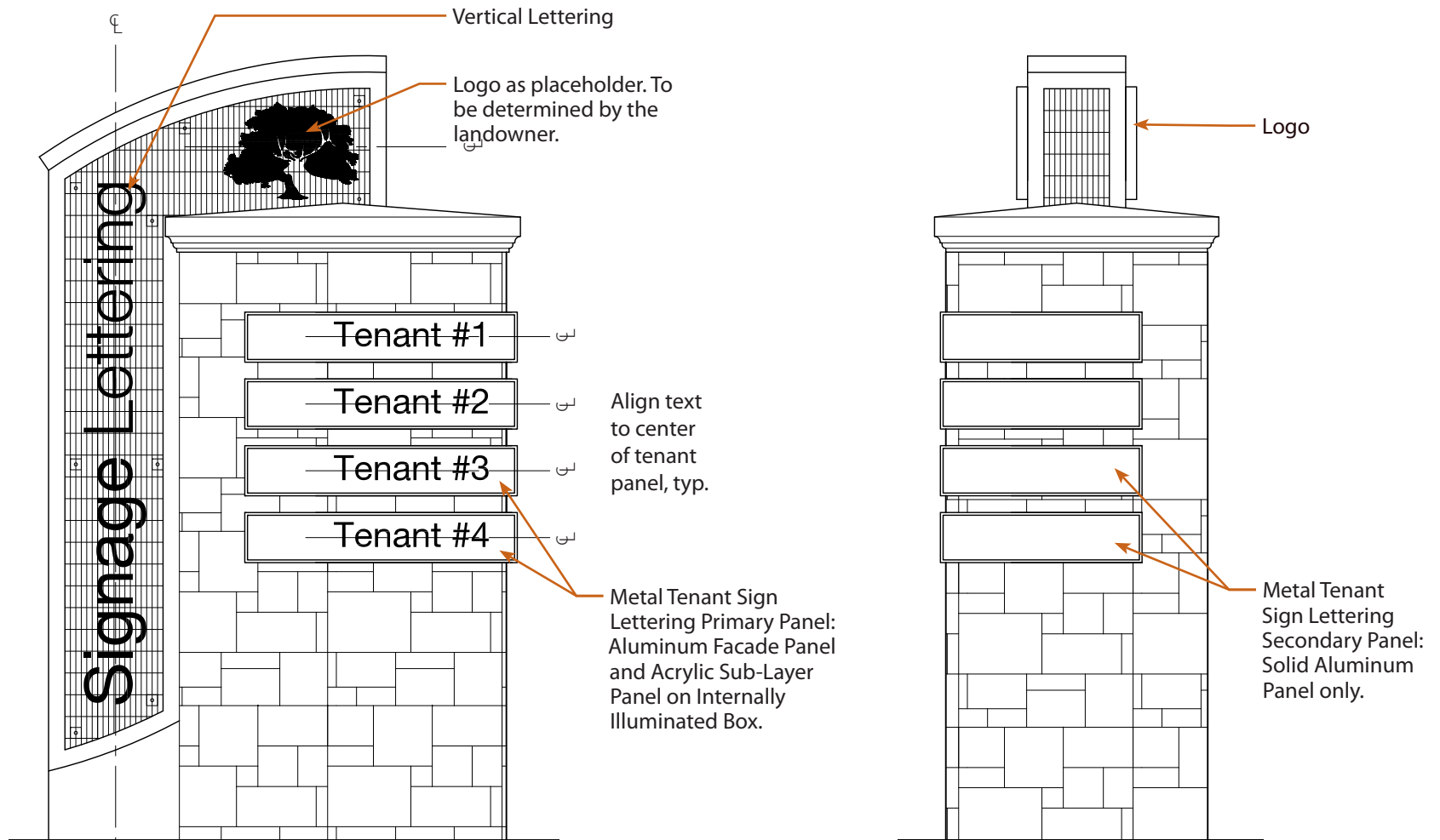

**Office and Light Industrial/Flex
Lettering and Logo Requirements
Elevation A (Street Side) - Not to Scale**

**Office and Light Industrial/Flex
Lettering and Logo Requirements
Elevation B (Driveway Side) - Not to Scale**

4. Reference Items**Planting and Landscape**

Refer to the following chapters of this Manual as required:

1. Primary Street Tree (refer to Chapter 6)
2. Major Accent Tree (refer to Chapter 6)
3. Accent Tree (refer to Chapter 6)
4. Specimen Tree (Refer to Chapter 6)
5. Large Shrub (refer to Chapter 6)
6. Medium Shrub (refer to Chapter 6)
7. Small Shrub (refer to Chapter 6)
8. Small Shrubs & Groundcover (refer to Chapter 6)
9. Vine (refer to Chapter 6)
10. Landscaping
(Private landscaping designed to the City's satisfaction and maintained by the landowner)

Hardscape and Amenities

Refer to the following chapters of this Manual: as required

1. Concrete Sidewalk. Score joints on-center spacing equal to width of sidewalk. Expansion joints spacing shall be as required per the Geotechnical Report. If no Geotechnical Report exists, expansion joints shall be every forth score joint

minimum. (Refer to Geotechnical Report for the specific lot within the Plan Area for specific information on slab thickness, reinforcement, etc.)

2. Colored Concrete Enhanced Paving (refer to Chapter 2)
3. City of Elk Grove Type 3 Concrete Curb (refer to City of Elk Grove Standard Details)
4. Colored Stamped Concrete Maintenance Safety Strip at Landscape Median/Turn Pocket (refer Chapter 2)
5. Concrete Mowstrip (refer to City of Elk Grove Standard Details)
6. Redwood Headerboard (refer to Chapter 4)
7. Edging for Residential Lots. To be determined by the City.
8. Colored Stamped Asphalt Enhanced Paving Crosswalks (refer to Chapter 2)
9. Community Walls (refer to this Chapter)
10. Community Pilaster (refer to this Chapter)
11. Low Pilaster (refer to this Chapter)
12. Residential Wood Fence (refer to this Chapter)
13. Open View Fence (refer to this Chapter)

14. Open View Fence with Low Wall (refer to this Chapter)
15. Split Rail Fence (refer to this Chapter)
16. Post and Cable Fence (refer to this Chapter)
17. Tubular Steel Fence with Accents (refer to this Chapter)
18. Courtyard Wall (refer to this Chapter)
19. Stone Veneer Courtyard Wall (refer to this Chapter)
20. Seatwall (refer to this Chapter)
21. Stone Veneer Seatwall (refer to this Chapter)
22. Primary Entry Monument (refer to this Chapter)
23. Secondary Entry Monument (refer to this Chapter)
24. Neighborhood Entry Monuments (refer to this Chapter)
25. Employment Area Entry Monument (refer to this Chapter)
26. Primary Streetlight (refer to Chapter 4)
27. Tree Root Barrier (refer to Chapter 4)
28. City of Elk Grove Visibility Control Area (refer to City of Elk Grove Standard Details)
29. Land Uses (refer to the SPA, Chapter 2 Land Plan)

C. ENTRY MONUMENTS

1. Entry Monuments Overview

Entry monuments highlight and strengthen the overall community design theme within the Plan Area with consistent materials, distinctive signage and iconic logos. Entry monuments are located at specific intersections and key nodes within the Plan Area. Entry monuments include Primary, Secondary, Neighborhood, and Employment Monuments. The monumentation elements are developed at differing scales and demonstrate the relationship to their specific location and purpose. Refer to the Entry Monuments Plan in this chapter for Entry Monument locations.

The specific stone, concrete cap, metal panels, metal lettering & logos, as well as other metal accents, shall be consistent and repeated throughout all entry monuments within the Plan Area. The Employment Area Entry Monuments shall also use the specified stone, but the color of the metal and size/scale of the monument may vary as required by the land use and number of tenants. Any deviation from the Employment Area Entry Monument as described in the Manual shall be approved by the City. Entry monuments shall be located either within the Landscape Area of a Landscape Corridor, driveway entrance to the project site, or in the interior of a particular land use, as determined by this Manual and as required by the City. Entry monument locations shall comply with all City view triangle and sight distance requirements and shall not impede the view of pedestrians and vehicles at road crossings or other intersections.

In addition to the entry monumentation, lettering and logos located on the monuments are equally important to establish the identity of the Plan Area. The Primary and Secondary Entry Monument lettering and logos are distinct and convey a sense of place.

The Neighborhood and Employment Area Entry Monument lettering and logos are more schematic in nature, allowing the landowner or developer of that land use to market and brand their specific product type, while still maintaining overall theme and character. Employment Monument lettering and logos are also schematic, specific design will be determined through design review. Lettering and logo content shown herein is for illustrative purposes only and final content shall be determined through subsequent branding of the area.

Entry monumentation within all land uses shall follow the theme and design intent as specified in this Manual. Design implementation and materials may be substituted from those specified in this Manual, as long as the design consistency of all entry monumentation, including lettering and logos, is maintained. Any deviation to materials and design intent shall be approved by the City.

Please note, the locations specified in this chapter are the minimum entry monument requirements. Each landowner or developer may propose additional entry monument locations to be approved by the City.

Additionally, monument setback dimensions shown in this chapter are minimum values only and may vary. All monument sign locations and setbacks shall be submitted, evaluated and approved by the City and CCSD during the entitlement stage of each development project.

CHAPTER 3

ENTRY MONUMENTS, WALLS & FENCES: ENTRY MONUMENTS

2. Application List

Entry monumentation, including lettering and logos, shall exist at the following street locations and land uses within the Plan Area (or as determined by the City):

Primary Monuments

1. At Kammerer Road and Bruceville Road
2. At Kammerer Road and Big Horn Boulevard
3. At Kammerer Road and Lotz Parkway
4. At Bilby Road and Bruceville Road
5. At Poppy Ridge Road and Big Horn Boulevard
6. At Whitelock Parkway and Lotz Parkway

Secondary Monuments

1. At Kammerer Road and Collector Commercial #1
2. At Poppy Ridge Road and Lotz Parkway (two locations)
3. At Poppy Ridge Road and Residential Collector #2
4. At Poppy Ridge Road and Residential Collector #3
5. At Big Horn Boulevard and Collector Residential #1
6. At Lotz Parkway and Collector Residential #1
7. At Bilby Road and Big Horn Boulevard (two locations)
8. At Bilby Road and Lotz Parkway
9. At Bilby Road and Commercial Main Street (both intersections - two locations)
10. Promenade Parkway

Neighborhood Entry Monuments (Optional)

Gateway Feature

1. Location as directed by the City

Employment Area Entry Monuments (Optional)

3. Entry Monument Plan

The Entry Monument Plan shows the location and type of Entry Monuments found within the Plan Area. Additional monuments may be added as determined by the City.



CHAPTER 3

ENTRY MONUMENTS, WALLS & FENCES: ENTRY MONUMENTS

4. Primary Entry Monument

Primary Entry Monuments are the largest monuments of all the entry monuments, and convey to the user that they have entered the Plan Area. These monuments occur at specific high-traffic street intersections and whenever possible, shall be located on both sides of an intersection. The Primary Entry Monument is a combination pilaster and monument wall with a major signage feature. This monument has a CMU block internal structure creating the pilaster and wall, and veneered with a manufactured stone on all sides of the monument. Both the pilaster and wall are capped by a custom precast concrete cap, sized specifically to each wall or pilaster element. The Primary Entry Monument includes a metal wrap-around panel with lettering and metal medallion with logo. All elements of the Primary Entry Monument shall be consistent throughout the entire Plan Area, including the exact same stone, concrete caps and metal accents, as well as identical signage lettering, verbiage and logo. Refer to General Standards and Reference Items section in this chapter for more information.

Design Elements

Refer to General Standards & Reference Items section this chapter for more information

- A. Primary Entry Monument (refer to Elevation B)
- B. Arterial Street (refer to Chapter 2)
- C. Concrete Sidewalk
- D. City of Elk Grove Type 3 Concrete Curb
- E. Landscaping, typ. (refer to Primary Entry Monument Plan - Enlargement)
- F. Office Land Use (refer to Special Planning Area Document, Chapter 2)
- G. Commercial Land Use (refer to Special Planning Area Document, Chapter 2)

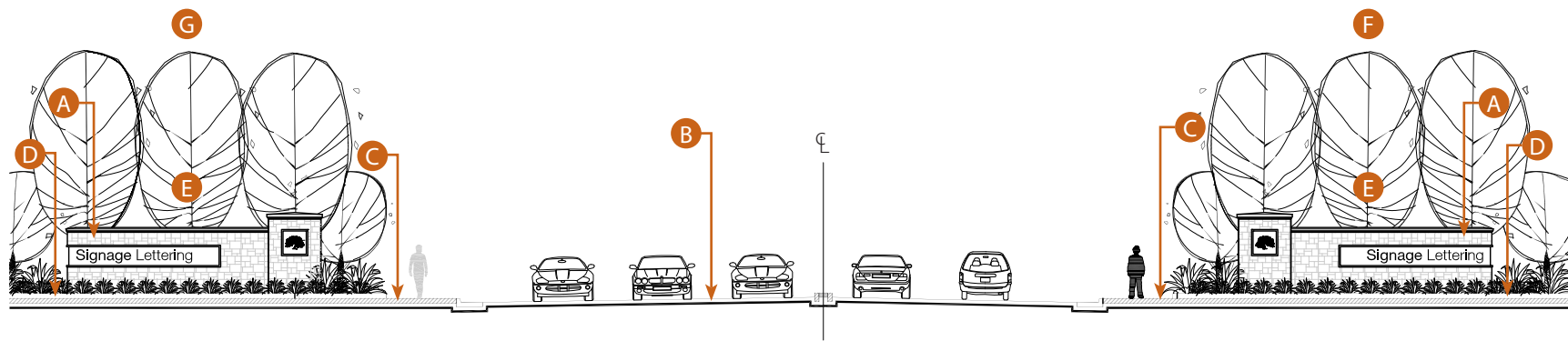

Primary Entry Monument - Elevation A

Not to Scale

Design Elements

Refer to General Standards & Reference Items section this chapter for more information

- 1. Pilaster
- 2. Pilaster Cap
- 3. Metal Medallion
- 4. Wall
- 5. Wall Cap
- 6. Stone Veneer
- 7. Metal Wrap-Around Panel (refer to Metal Wrap-Around Panel Attachment detail)
- 8. Landscaping, typ. (not shown - refer to Primary Entry Monument - Plan Enlargement)
- 9. Concrete Masonry Unit Block (CMU) at Monument
- 10. Stone Veneer Mortar Bed
- 11. Lettering Attached to Metal Wrap-Around Panel
- 12. Metal Wrap-Around Panel Attached to CMU Block
- 13. Lettering (TBD)
- 14. Logo (TBD)

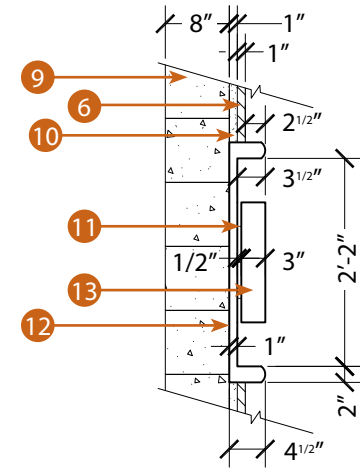

Metal Wrap-Around Panel Attachment

Not to Scale

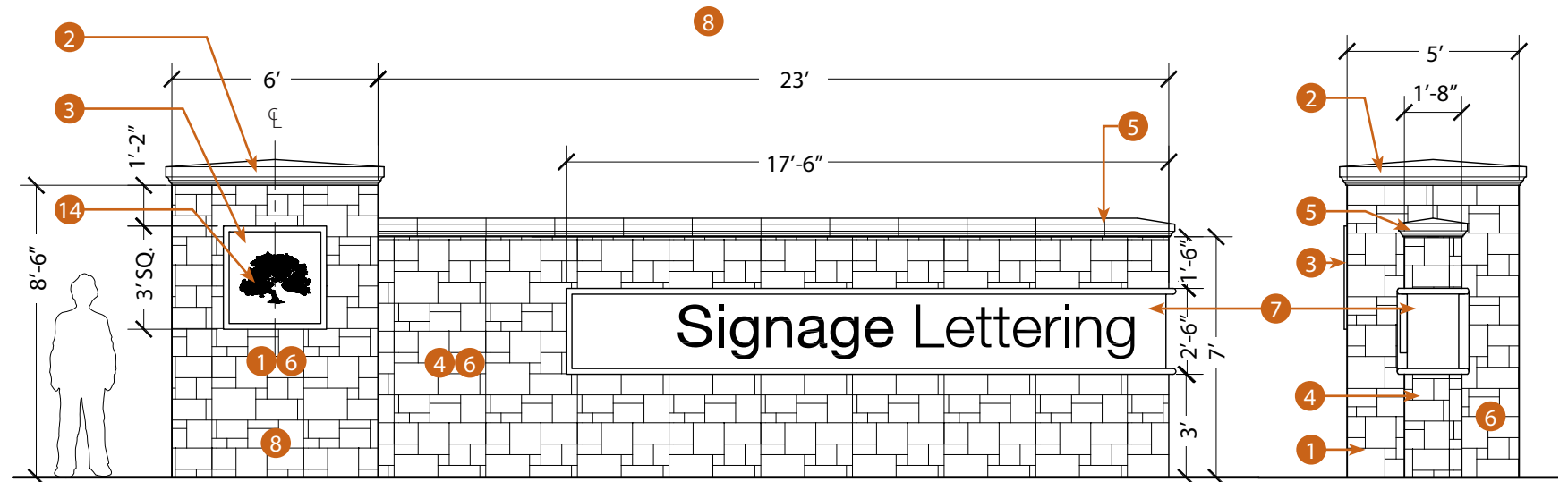

Primary Entry Monument - Elevation B

Not to Scale

Primary Entry Monument - Section

Not to Scale

CHAPTER 3

ENTRY MONUMENTS, WALLS & FENCES: ENTRY MONUMENTS

Design Elements

Refer to General Standards & Reference Items section this chapter for more information

- A. Primary Entry Monument
- B. Kammerer Road
- C. Arterial Street (refer to Chapter 2)
- D. Concrete Sidewalk
- E. Colored Concrete Enhanced Paving
- F. Colored Stamped Asphalt Enhanced Paving Crosswalk
- G. City of Elk Grove Type 3 Concrete Curb
- H. City of Elk Grove Visibility Control Area
- I. Colored Stamped Concrete Maintenance Safety Strip at Landscape Median/Turn Pocket
- J. Landscaping, typ. (refer to Primary Entry Monument - Plan Enlargement)
- K. Office Land Use (refer to Special Planning Area Document, Chapter 2)
- L. Commercial Land Use (refer to Special Planning Area Document, Chapter 2)
- M. Tree Root Barrier

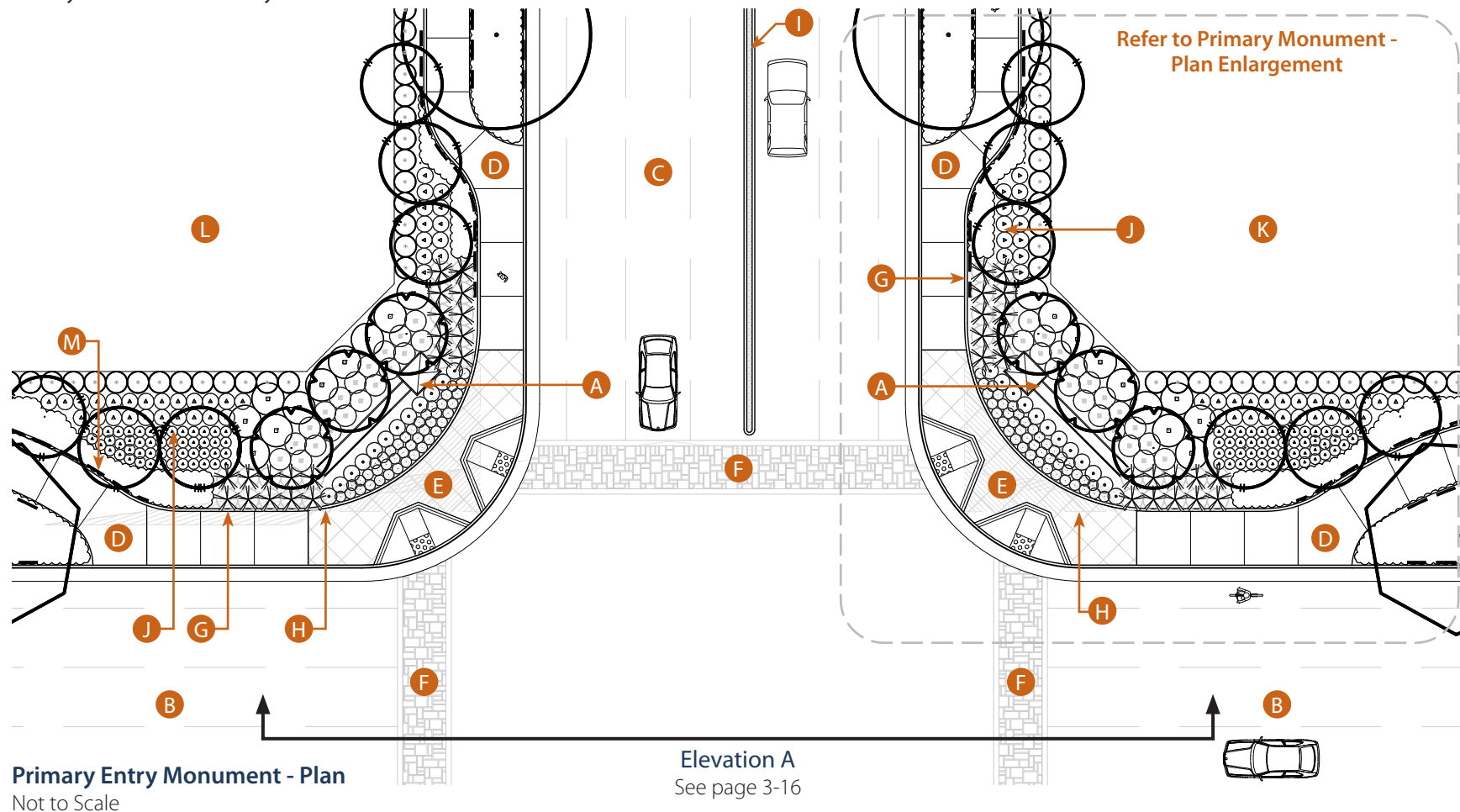

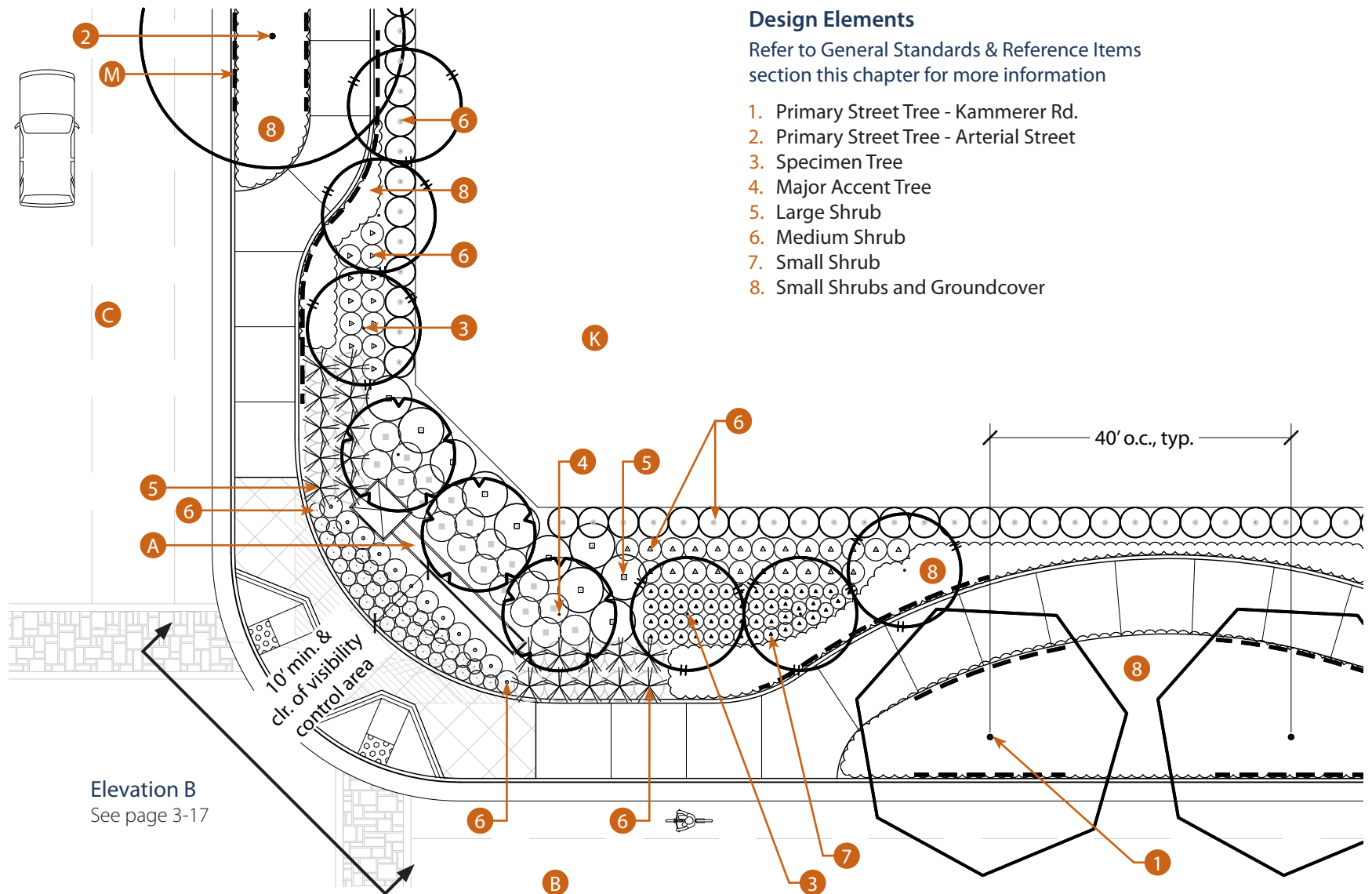

Design Elements

Refer to General Standards & Reference Items section this chapter for more information

1. Primary Street Tree - Kammerer Rd.
2. Primary Street Tree - Arterial Street
3. Specimen Tree
4. Major Accent Tree
5. Large Shrub
6. Medium Shrub
7. Small Shrub
8. Small Shrubs and Groundcover

Elevation B
See page 3-17

Primary Entry Monument - Plan Enlargement
Not to Scale

CHAPTER 3

ENTRY MONUMENTS, WALLS & FENCES: ENTRY MONUMENTS

5. Secondary Entry Monument

Secondary Entry Monuments are nearly identical in design and materials to that of the Primary Entry Monument, however they are slightly smaller in scale. Secondary Entry Monuments occur at specific Arterial Street intersections, including Kammerer Road, as one enters the Plan Area. Whenever possible, the Secondary Entry Monument shall be located on both sides of an intersection. Similar to the Primary Entry Monument, the Secondary Monument is a combination pilaster and monument wall, with a major signage feature. This monument has a CMU block internal structure creating the pilaster and wall and veneered with a manufactured stone on all sides of the monument. Both the pilaster and wall are capped by a custom precast concrete cap, sized specifically to each wall or pilaster element. The Secondary Entry Monument signage includes a metal wrap-around panel with lettering and metal medallion with logo. All elements of the Secondary Entry Monument shall be consistent throughout the entire Plan Area including stone, concrete caps and metal accents, as well as identical signage lettering, verbiage and logo. Refer to General Standards and Reference Items section in this chapter for more information.

Design Elements

Refer to General Standards & Reference Items section this chapter for more information

- A. Secondary Entry Monument (refer to Elevation B)
- B. Residential Collector (refer to Chapter 2)
- C. Concrete Sidewalk
- D. Community Wall
- E. Community Pilaster
- F. City of Elk Grove Type 3 Concrete Curb
- G. Landscaping, typ. (refer to Secondary Entry Monument Plan - Enlargement)
- H. Residential Land Use (refer to Special Planning Area Document, Chapter 2)

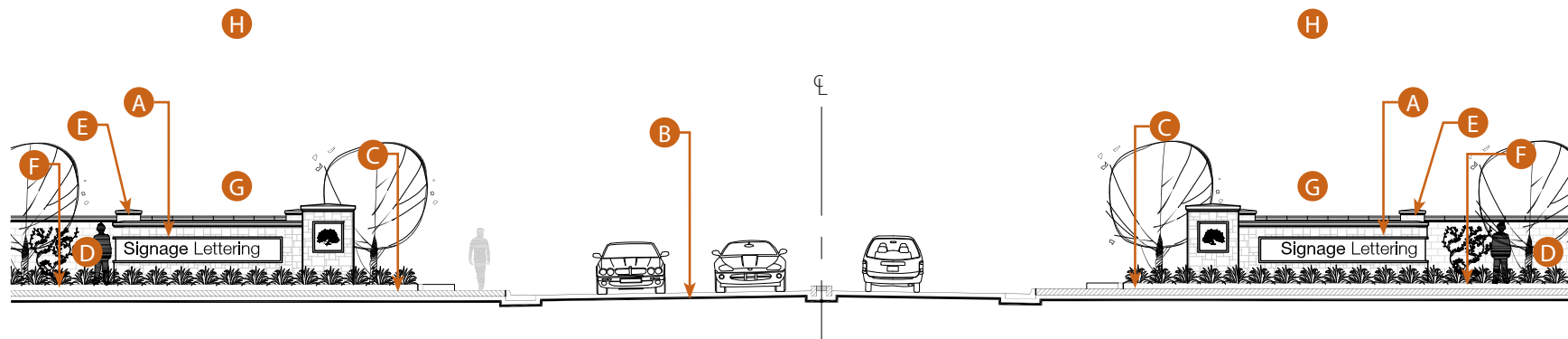

Secondary Entry Monument - Elevation A

Not to Scale

Design Elements

Refer to General Standards & Reference Items section this chapter for more information

- | | |
|---|---|
| 1. Pilaster | 9. Concrete Masonry Unit Block (CMU) at Monument |
| 2. Pilaster Cap | 10. Stone Veneer Mortar Bed |
| 3. Metal Medallion | 11. Lettering Attached to Metal Wrap-Around Panel |
| 4. Wall | 12. Metal Wrap-Around Panel Attached to CMU Block |
| 5. Wall Cap | 13. Lettering (TBD) |
| 6. Stone Veneer | 14. Logo (TBD) |
| 7. Metal Wrap-Around Panel (refer to Metal Wrap-Around Panel Attachment detail) | |
| 8. Landscaping, typ. (not shown - refer to Secondary Entry Monument - Plan Enlargement) | |

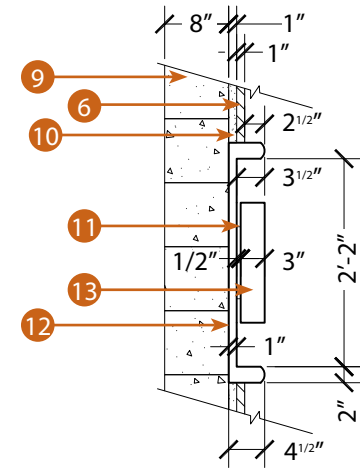

Metal Wrap-Around Panel Attachment

Not to Scale

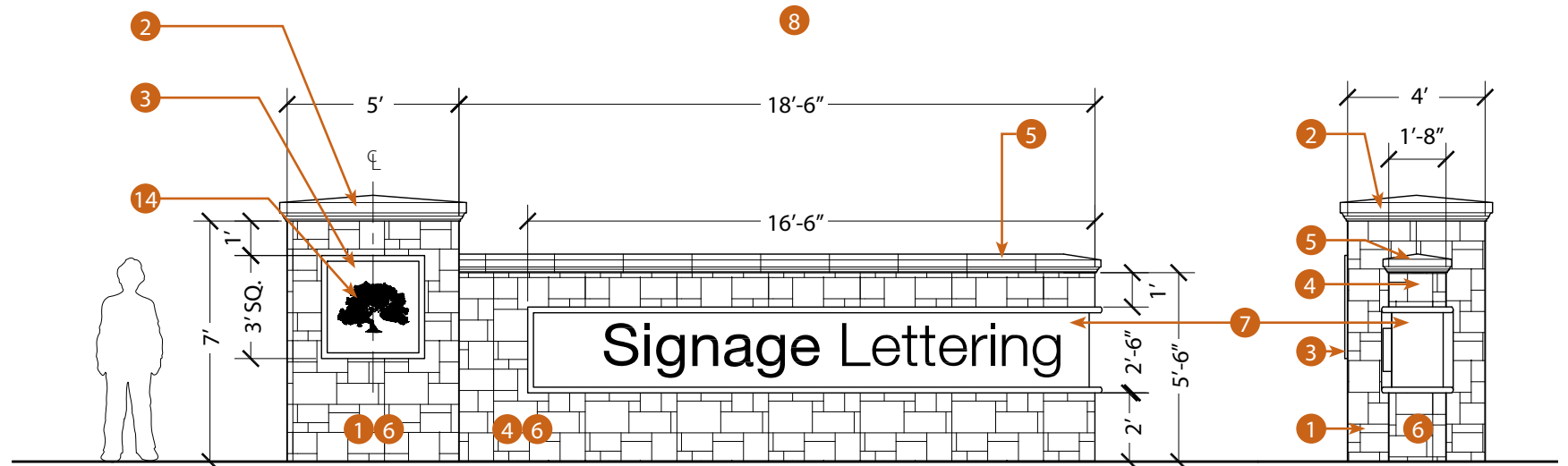

Secondary Entry Monument - Elevation B

Not to Scale

Secondary Entry Monument - Section

Not to Scale

CHAPTER 3

ENTRY MONUMENTS, WALLS & FENCES: ENTRY MONUMENTS

Design Elements

Refer to General Standards & Reference Items section this chapter for more information

- A. Secondary Entry Monument
- B. Community Wall with Community Pilaster
- C. Arterial Street (refer to Chapter 2)
- D. Residential Collector (refer to Chapter 2)
- E. Concrete Sidewalk
- F. Colored Concrete Enhanced Paving
- G. Colored Stamped Asphalt Enhanced Paving Crosswalk
- H. City of Elk Grove Type 3 Concrete Curb
- I. City of Elk Grove Visibility Control Area
- J. Colored Stamped Concrete Maintenance Safety Strip at Landscape Median/Turn Pocket
- K. Landscaping, typ. (refer to Secondary Monument - Plan Enlargement)
- L. Residential Land Use (refer to Special Planning Area Document, Chapter 2)
- M. Tree Root Barrier

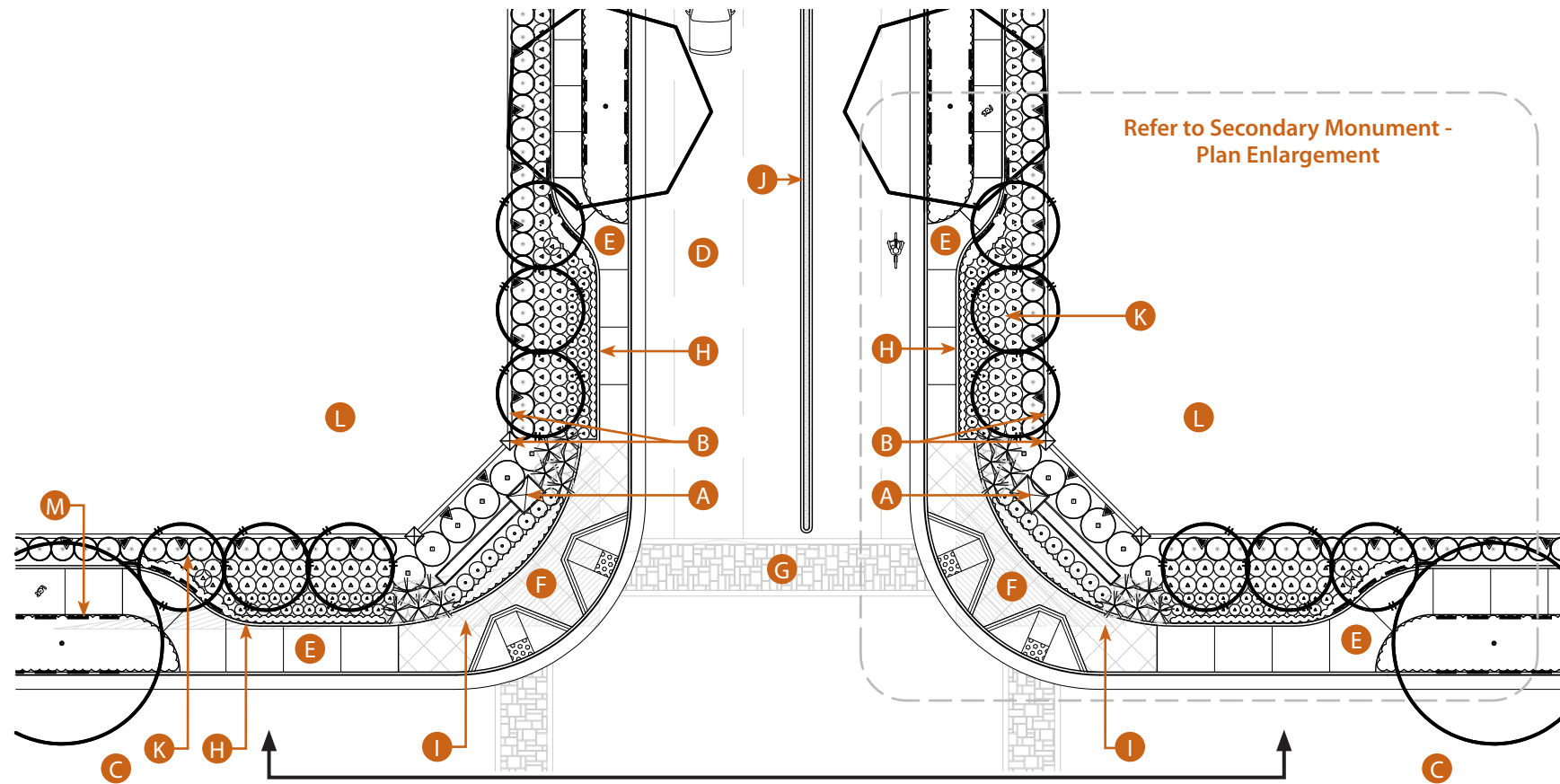

Secondary Entry Monument - Plan

Not to Scale

Elevation A

See page 3-20

Design Elements

Refer to General Standards & Reference Items section this chapter for more information

- 1. Primary Street Tree - Arterial Street
- 2. Primary Street Tree - Residential Collector
- 3. Specimen Tree
- 4. Large Shrub
- 5. Medium Shrub
- 6. Small Shrub
- 7. Small Shrubs & Groundcover
- 8. Vine

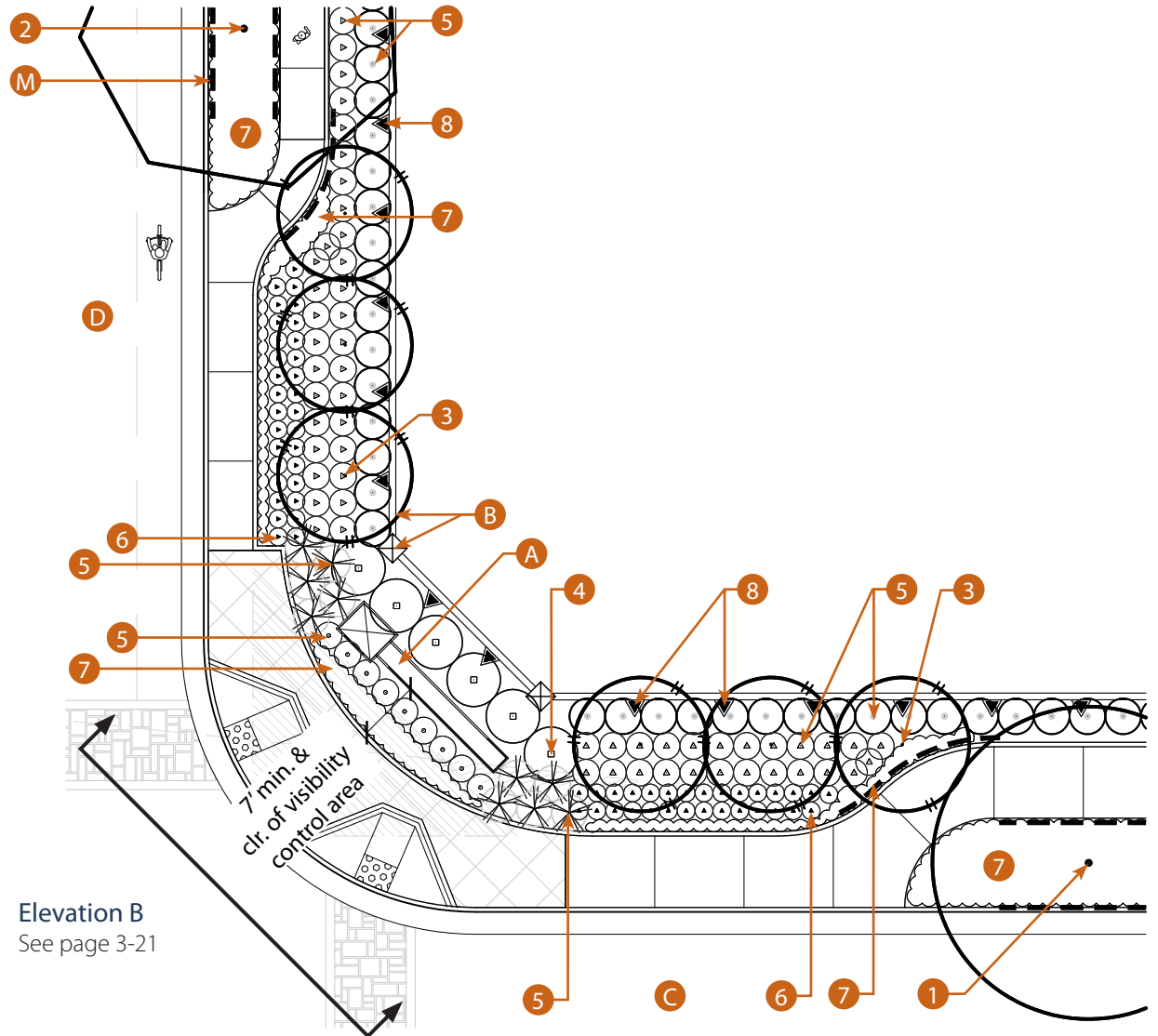

Elevation B
See page 3-21

Secondary Entry Monument - Plan Enlargement
Not to Scale

6. Neighborhood Entry Monument Overview

Neighborhood Entry Monuments convey to the user they have entered a specific residential neighborhood within the Plan Area. These monuments occur at Arterial and residential land use street intersections, and vary in size and scale depending on the particular street dimensions, residential product type, and appropriate branding and marketing of the residential product type. The intent of the Neighborhood Entry Monument is not to require one particular Neighborhood Entry Monument at every residential neighborhood intersection, but to allow the landowner or residential unit builder to select the monument that best conveys their product type and best fits within the constraints of each street and intersection. Whenever possible, Neighborhood Entry Monuments shall be located on both sides of a street or intersection. Additionally, Neighborhood Entry Monuments may be used in combination with Secondary Entry Monuments where Arterial Streets intersect with a Collector Residential Streets. The landowner or residential unit builder shall name their individual community and create a logo for their community, which shall be located on the entry monument(s) within their project area. The specific content and verbiage of the lettering and logos contained on Neighborhood Entry Monuments shall be proposed by the landowner or residential unit builder and approved by the City. Although Neighborhood Entry Monuments vary slightly in materials, size and scale, all monuments shall use the exact same stone, concrete caps and type of metal, consistent throughout the entire Plan Area. Neighborhood Entry Monuments are not required but are strongly encouraged to promote the Plan Area’s design aesthetic and distinct identity.

7. Neighborhood Entry Monument #1

Neighborhood Entry Monument #1 uses a combination of pilasters, low walls and metal panels, with varied community signage. These monuments have a CMU block internal structure creating the pilaster and low wall, and veneered with a manufactured stone on all sides of the monument. Both the pilaster and walls are capped by a custom precast concrete cap, sized specifically to each pilaster and low wall element. Neighborhood Entry Monument #1 includes a metal wrap-around panel with lettering and logo and a metal grid panel. Refer to Neighborhood Entry Monument Overview as well as General Standards and Reference Items sections in this chapter for more information.

Design Elements

Refer to General Standards & Reference Items section this chapter for more information

- A. Neighborhood Entry Monument #1 (refer to Elevation B)
- B. Residential Collector (or Local Residential Street)
- C. Concrete Sidewalk
- D. Community Wall
- E. Community Pilaster
- F. City of Elk Grove Type 3 Concrete Curb
- G. Landscaping, typ. (refer to Neighborhood Entry Monument #1 Plan - Enlargement)
- H. Residential Land Use (refer to Special Planning Area Document, Chapter 2)

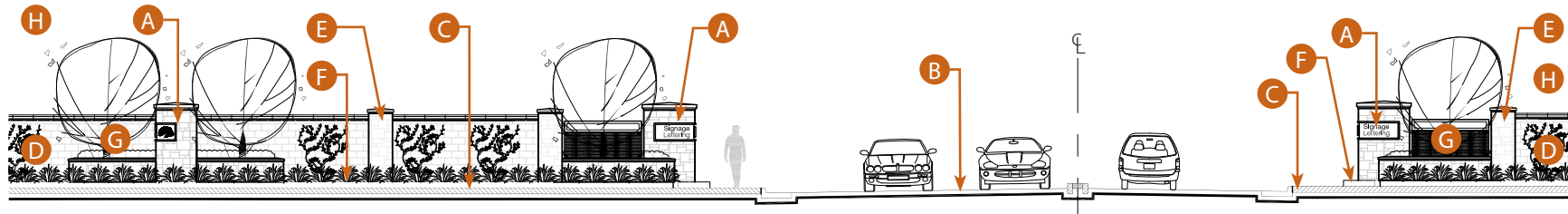

Neighborhood Entry Monument #1 - Elevation A

Not to Scale

Design Elements

Refer to General Standards & Reference Items section this chapter for more information

- | | |
|---|---|
| <ol style="list-style-type: none"> 1. Pilaster 2. Pilaster Cap 3. Wall 4. Wall Cap 5. Metal Grid Panel 6. Stone Veneer 7. Raised Planter Bed 8. Metal Wrap-Around Panel
(refer to Metal Wrap-Around Panel Attachment detail) 9. Landscaping, typ. (not shown - refer to Neighborhood Entry Monument #1 - Plan Enlargement) | <ol style="list-style-type: none"> 10. Concrete Masonry Unit Block (CMU) at Monument 11. Stone Veneer Mortar Bed 12. Lettering Attached to Metal Wrap-Around Panel 13. Metal Wrap-Around Panel Attached to CMU Block 14. Lettering (TBD) 15. Logo (TBD) 16. Community Pilaster 17. Community Wall |
|---|---|

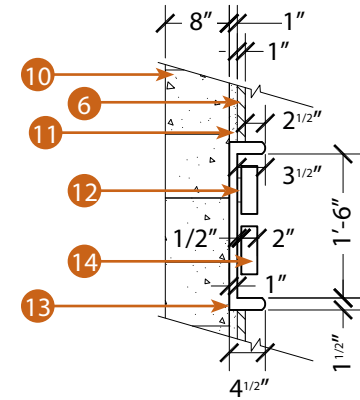

Metal Wrap-Around Panel Attachment

Not to Scale

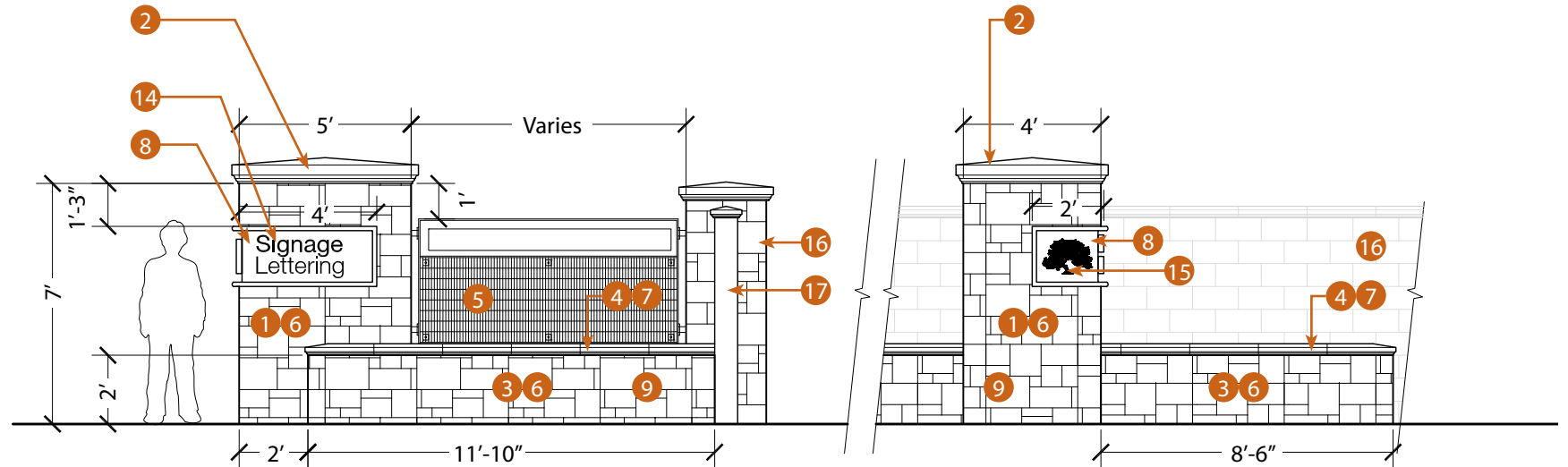

Neighborhood Entry Monument #1 - Elevation B

Not to Scale

Neighborhood Entry Monument #1 - Section

Not to Scale

CHAPTER 3

ENTRY MONUMENTS, WALLS & FENCES: ENTRY MONUMENTS

Design Elements

Refer to General Standards & Reference Items section this chapter for more information

- A. Neighborhood Entry Monument #1
- B. Community Wall
- C. Community Pilaster
- D. Arterial Street (or Residential Collector Street)
- E. Residential Collector Street (or Local Residential Street)
- F. Concrete Sidewalk
- G. Colored Concrete Enhanced Paving
- H. Colored Stamped Asphalt Enhanced Paving Crosswalk (if Arterial Street)
- I. City of Elk Grove Type 3 Concrete Curb
- J. City of Elk Grove Visibility Control Area
- K. Colored Stamped Concrete Maintenance Safety Strip at Landscape Median/Turn Pocket
- L. Landscaping, typ. (refer to Neighborhood Entry #1 Monument - Plan Enlargement)
- M. Residential Land Use (refer to Special Planning Area Document, Chapter 2)
- N. Tree Root Barrier

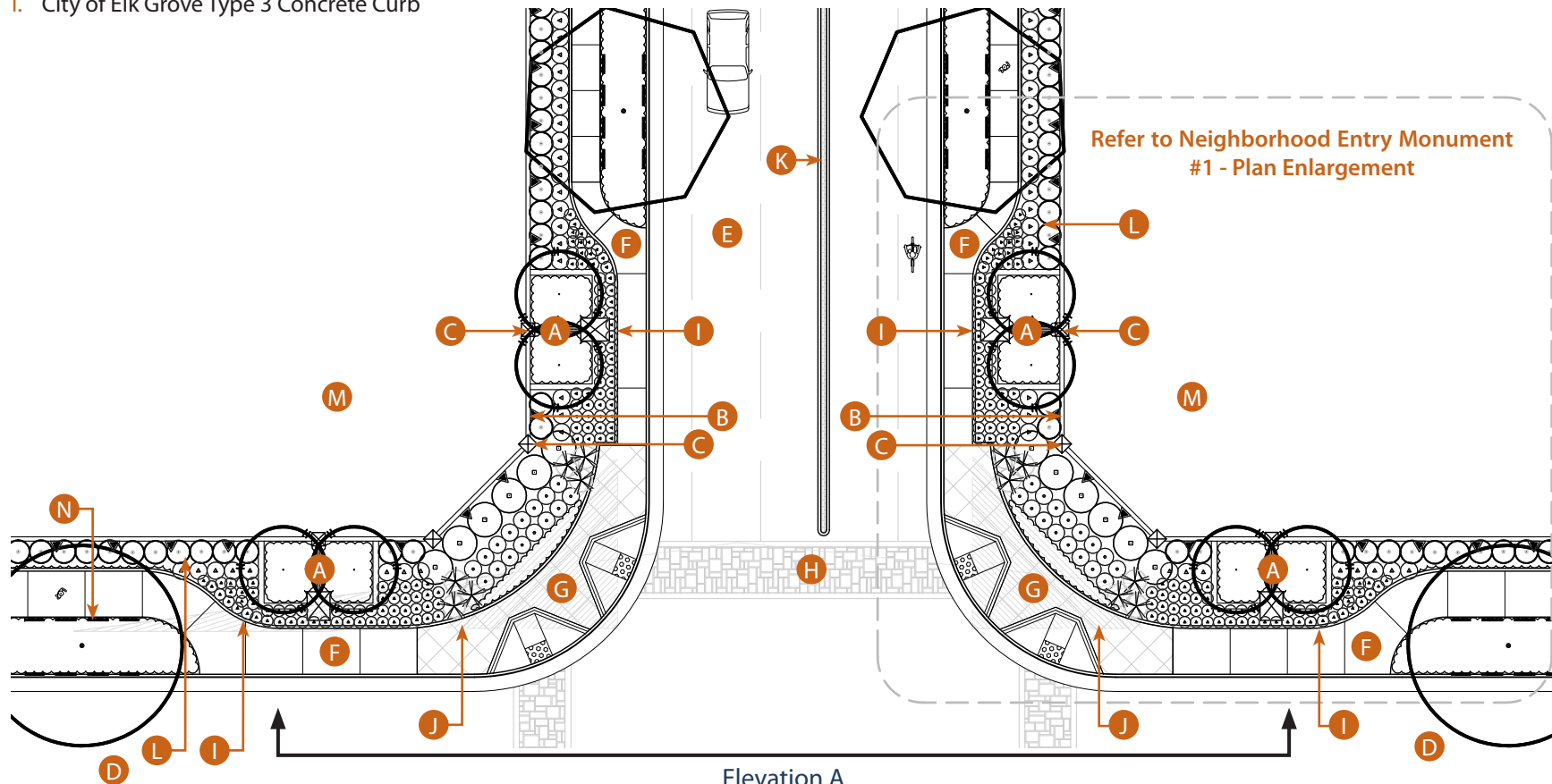

Neighborhood Entry Monument #1 - Plan
Not to Scale

Elevation A
See page 3-24

Design Elements

Refer to General Standards & Reference Items section this chapter for more information

- 1. Primary Street Tree - Arterial Street or Residential Collector
- 2. Primary Street Tree - Residential Collector or Local Residential
- 3. Specimen Tree
- 4. Large Shrub
- 5. Medium Shrub
- 6. Small Shrub
- 7. Small Shrubs & Groundcover
- 8. Vine

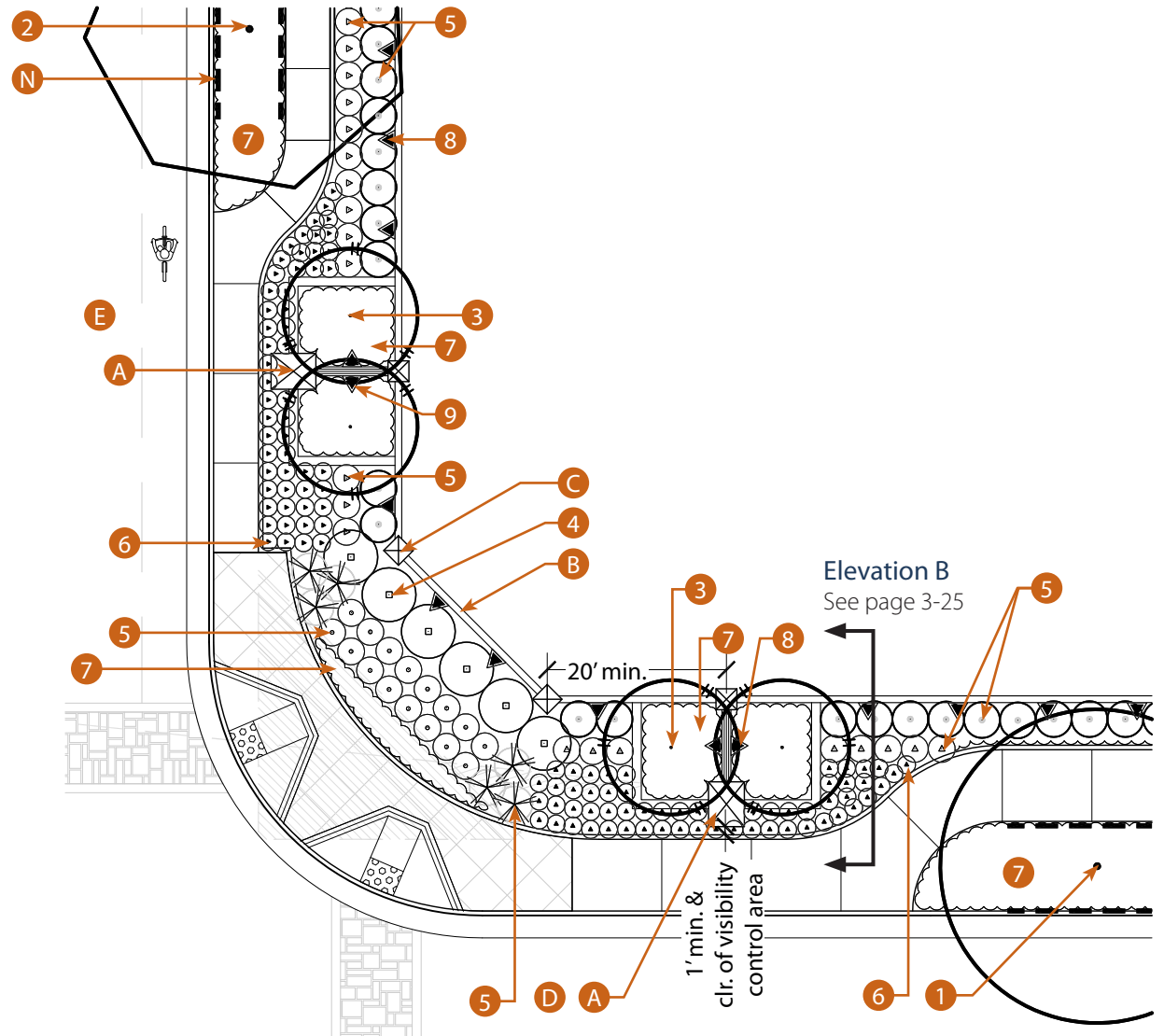

Neighborhood Entry Monument #1- Plan Enlargement
Not to Scale

CHAPTER 3

ENTRY MONUMENTS, WALLS & FENCES: ENTRY MONUMENTS

8. Neighborhood Entry Monument #2

Neighborhood Entry Monument #2 uses a combination of pilasters, low walls and metal panels, with varied community signage. These monuments have a CMU block internal structure creating the pilaster and low wall, and veneered with a manufactured stone on all sides of the monument. Both the pilaster and walls are capped by a custom precast concrete cap, sized specifically to each pilaster and low wall element. Neighborhood Entry Monument #2 includes a metal wrap-around panel with lettering and logo and a metal grid panel. Refer to Neighborhood Entry Monument Overview as well as General Standards and Reference Items sections in this chapter for more information.

Design Elements

Refer to General Standards & Reference Items section this chapter for more information

- A. Neighborhood Entry Monument #1 (refer to Elevation B)
- B. Arterial Street (or Residential Collector)
- C. Concrete Sidewalk
- D. Community Wall
- E. Community Pilaster
- F. City of Elk Grove Type 3 Concrete Curb
- G. Landscaping, typ. (refer to Neighborhood Entry Monument #2 Plan - Enlargement)
- H. Residential Land Use (refer to Special Planning Area Document, Chapter 2)

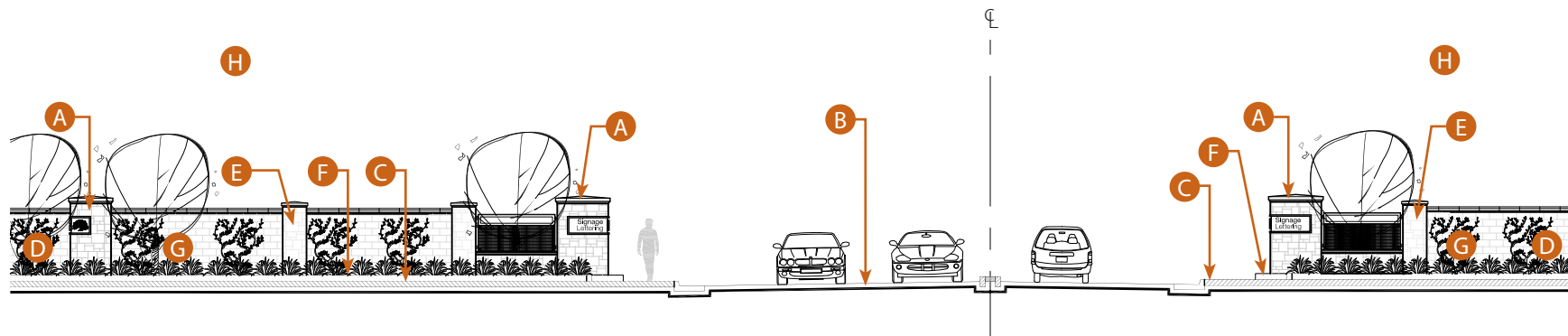

Neighborhood Entry Monument #2 - Elevation A

Not to Scale

Design Elements

Refer to General Standards & Reference Items section this chapter for more information

- | | |
|---|---|
| 1. Pilaster | 9. Concrete Masonry Unit Block (CMU) at Monument |
| 2. Pilaster Cap | 10. Stone Veneer Mortar Bed |
| 3. Wall | 11. Lettering Attached to Metal Wrap-Around Panel |
| 4. Wall Cap | 12. Metal Wrap-Around Panel Attached to CMU Block |
| 5. Metal Grid Panel | 13. Lettering (TBD) |
| 6. Stone Veneer | 14. Logo (TBD) |
| 7. Metal Wrap-Around Panel (refer to Metal Wrap-Around Panel Attachment detail) | 15. Community Pilaster |
| 8. Landscaping, typ. (not shown - refer to Neighborhood Entry Monument #2 - Plan Enlargement) | 16. Community Wall |

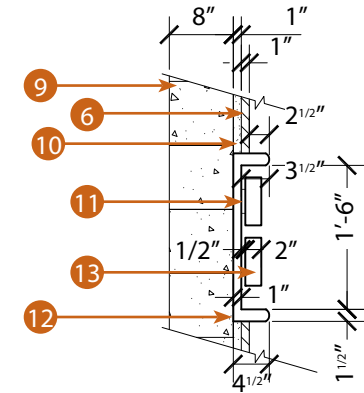

Metal Wrap-Around Panel Attachment

Not to Scale

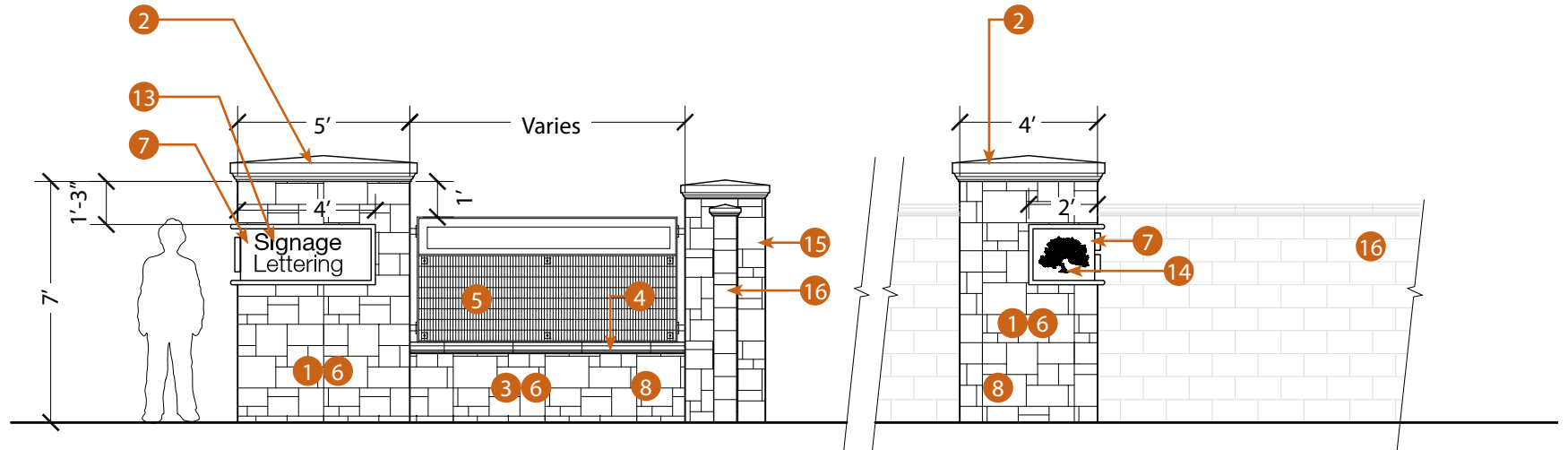

Neighborhood Entry Monument #2 - Elevation B

Not to Scale

Neighborhood Entry Monument #2 - Section

Not to Scale

CHAPTER 3

ENTRY MONUMENTS, WALLS & FENCES: ENTRY MONUMENTS

Design Elements

Refer to General Standards & Reference Items section this chapter for more information

- A. Neighborhood Entry Monument #2
- B. Community Wall
- C. Community Pilaster
- D. Arterial Street (or Residential Collector)
- E. Residential Collector (or Local Residential Street)
- F. Concrete Sidewalk
- G. Colored Concrete Enhanced Paving
- H. Colored Stamped Asphalt Enhanced Paving Crosswalk (if Arterial Street)
- I. City of Elk Grove Type 3 Concrete Curb
- J. City of Elk Grove Visibility Control Area
- K. Colored Stamped Concrete Maintenance Safety Strip at Landscape Median/Turn Pocket
- L. Landscaping, typ. (refer to Neighborhood Entry Monument #2 - Plan Enlargement)
- M. Residential Land Use (refer to Special Planning Area Document, Chapter 2)
- N. Tree Root Barrier

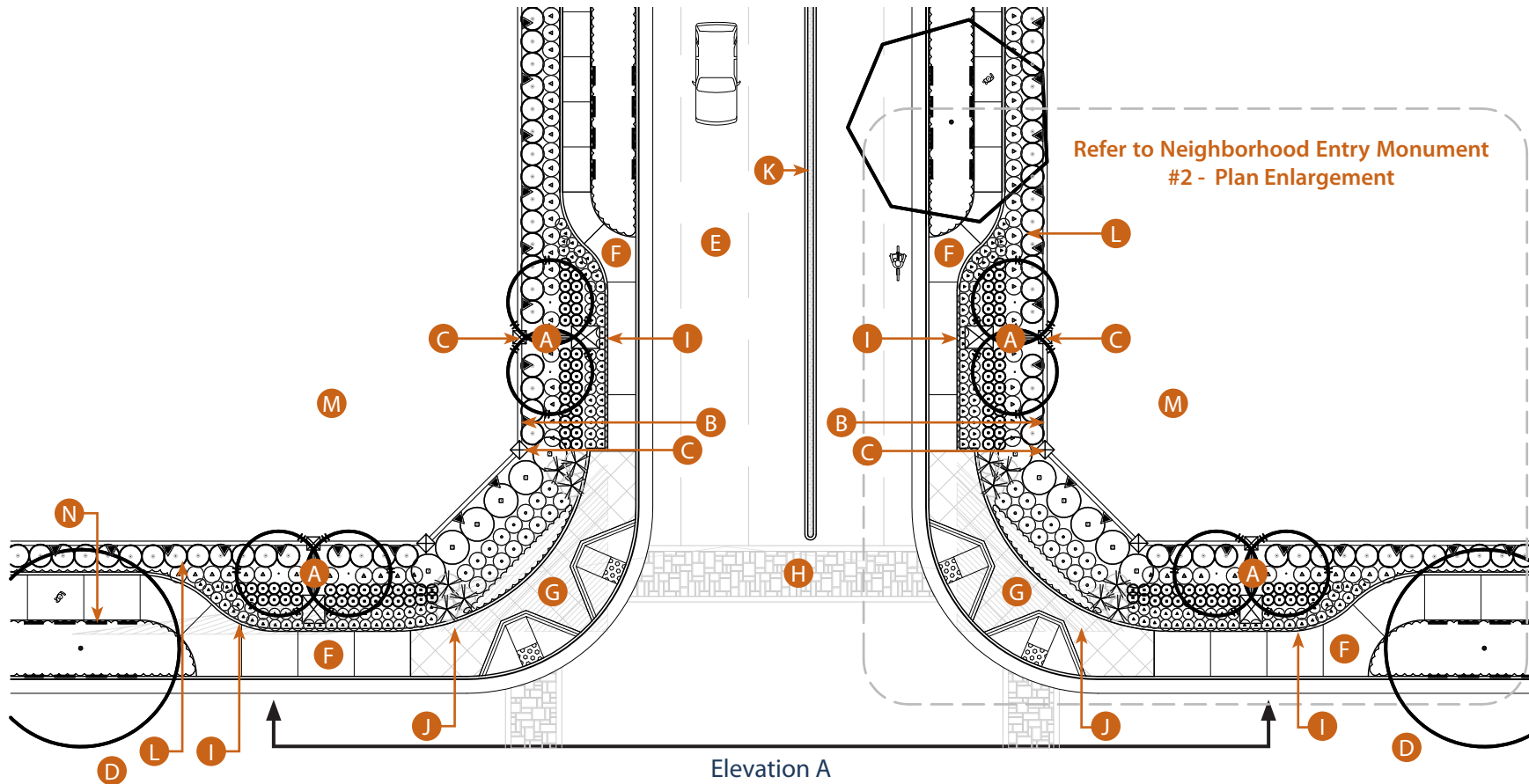

Elevation A
See page 3-28

Neighborhood Entry Monument #2 - Plan

Not to Scale

Design Elements

Refer to General Standards & Reference Items section this chapter for more information

1. Primary Street Tree - Arterial Street or Residential Collector
2. Primary Street Tree - Residential Collector or Local Residential
3. Specimen Tree
4. Large Shrub
5. Medium Shrub
6. Small Shrub
7. Small Shrubs & Groundcover
8. Vine

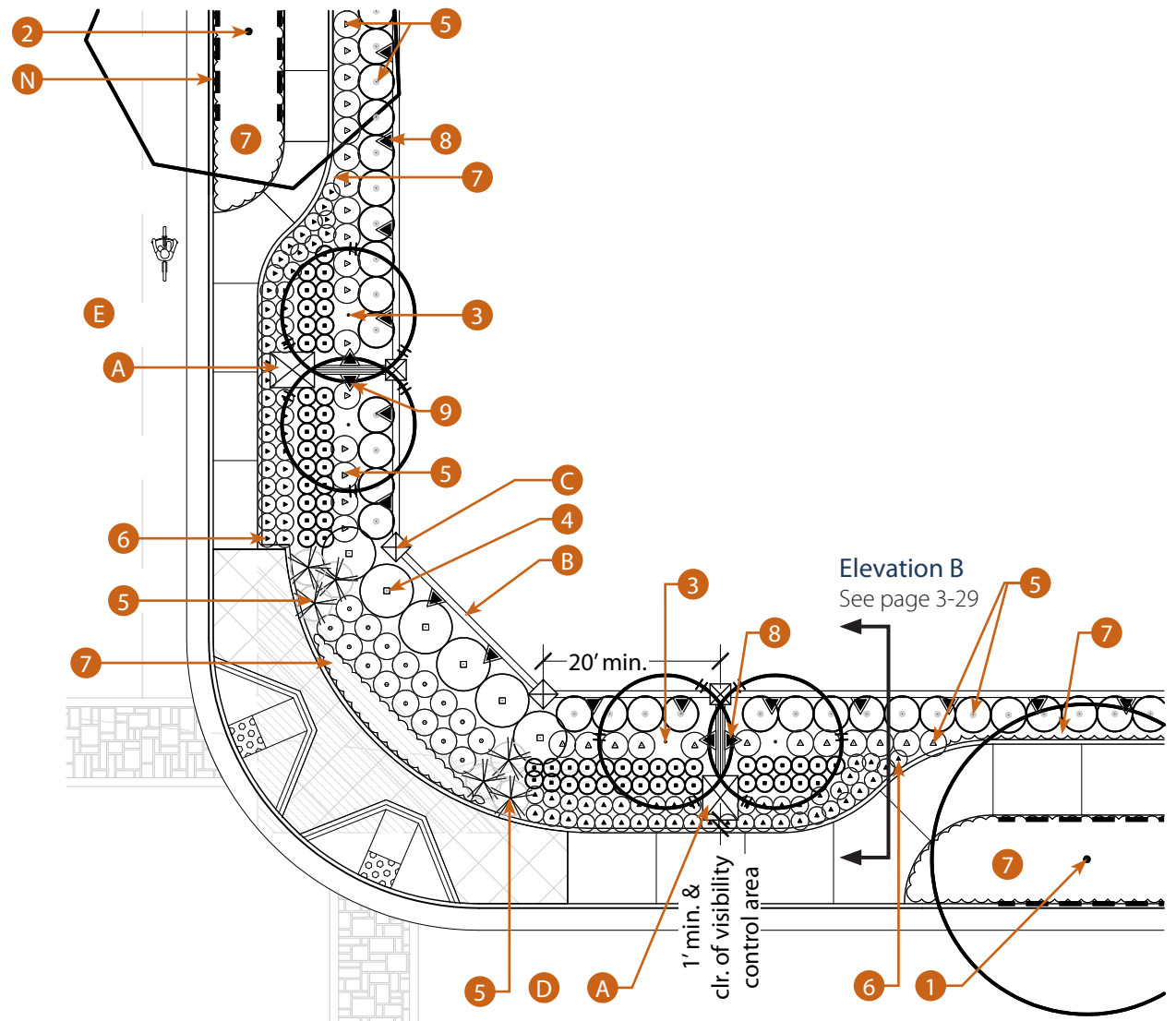

Neighborhood Entry Monument #2 - Plan Enlargement
Not to Scale

CHAPTER 3

ENTRY MONUMENTS, WALLS & FENCES: ENTRY MONUMENTS

9. Neighborhood Entry Monument #3

Neighborhood Entry Monument #3 uses a combination of a pilaster, low wall and metal medallion/panel, with varied community signage. These monuments have a CMU block internal structure creating the pilaster and low wall, and veneered with a manufactured stone on all sides of the monument. Both the pilaster and walls are capped by a custom precast concrete cap, sized specifically to each pilaster and low wall element. Neighborhood Entry Monument #3 includes a metal medallion with lettering and a metal grid panel. Refer to Neighborhood Entry Monument Overview as well as General Standards and Reference Items sections in this chapter for more information.

Design Elements

Refer to General Standards & Reference Items section this chapter for more information

- A. Neighborhood Entry Monument #3 (refer to Elevation B)
- B. Local Residential Street
- C. Concrete Sidewalk
- D. Community Wall
- E. Community Pilaster
- F. City of Elk Grove Type 3 Concrete Curb
- G. Landscaping, typ. (refer to Neighborhood Entry Monument #3 - Plan Enlargement)
- H. Residential Land Use (refer to Special Planning Area Document, Chapter 2)

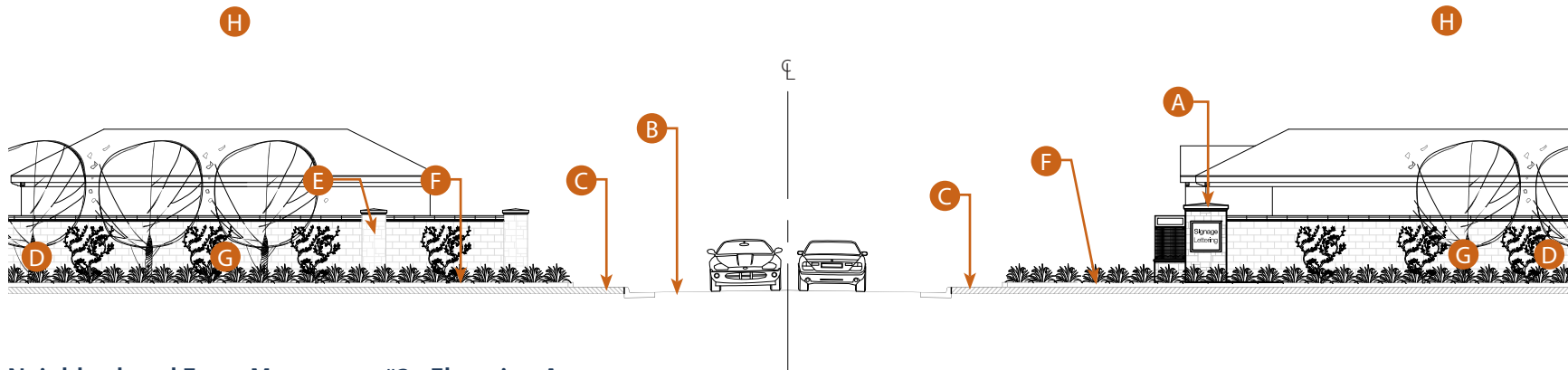

Neighborhood Entry Monument #3 - Elevation A

Not to Scale

Design Elements

Refer to General Standards & Reference Items section this chapter for more information

- | | |
|---|--|
| 1. Pilaster | 9. Concrete Masonry Unit Block (CMU) at Monument |
| 2. Pilaster Cap | 10. Stone Veneer Mortar Bed |
| 3. Wall | 11. Lettering Attached to Metal Panel |
| 4. Wall Cap | 12. Metal Panel Attached to CMU Block |
| 5. Metal Grid Panel | 13. Lettering (TBD) |
| 6. Stone Veneer | 14. Logo (TBD) |
| 7. Metal Panel (refer to Metal Panel Attachment detail) | 15. Community Pilaster |
| 8. Landscaping, typ. (not shown - refer to Neighborhood Entry Monument #3 - Plan Enlargement) | 16. Community Wall |

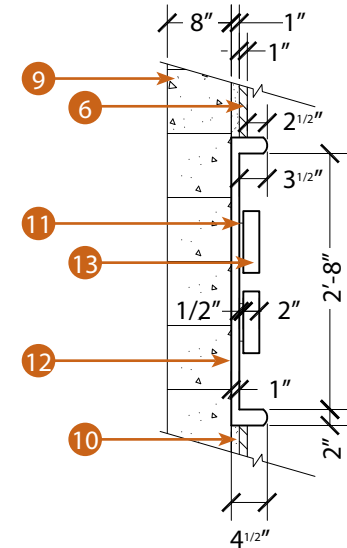

Metal Panel Attachment
Not to Scale

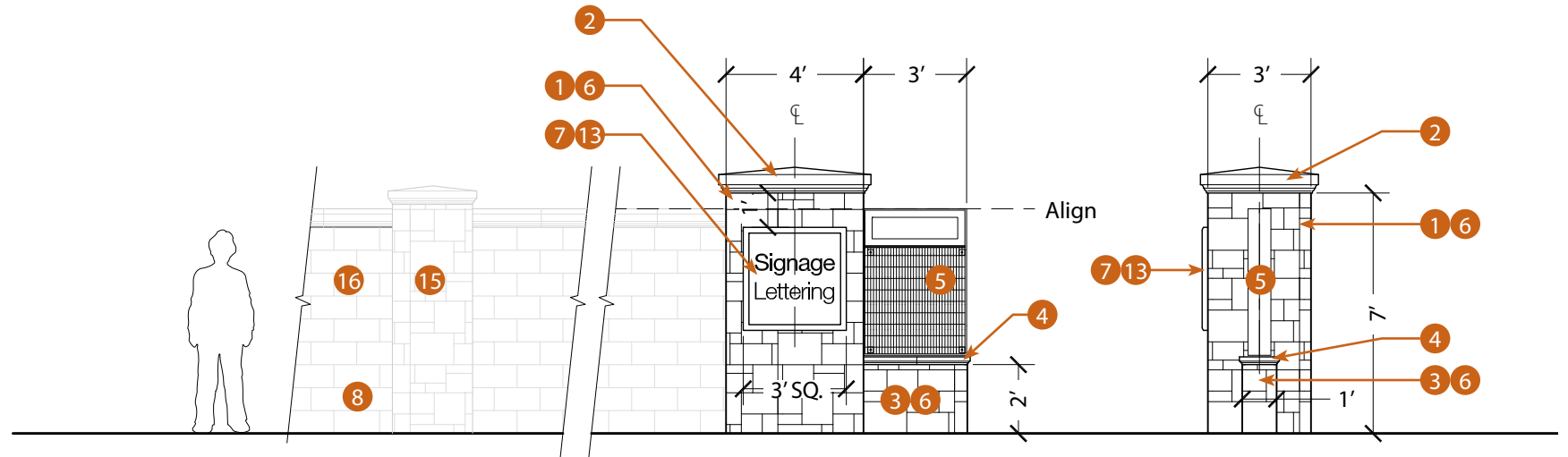

Neighborhood Entry Monument #3 - Elevation B
Not to Scale

Neighborhood Entry Monument #3 - Section
Not to Scale

CHAPTER 3

ENTRY MONUMENTS, WALLS & FENCES: ENTRY MONUMENTS

Design Elements

Refer to General Standards & Reference Items section this chapter for more information

- A. Neighborhood Entry Monument #3
- B. Community Wall
- C. Community Pilaster
- D. Residential Wood Fence
- E. Residential Collector
- F. Local Residential Street
- G. Concrete Sidewalk
- H. City of Elk Grove Type 3 Concrete Curb
- I. City of Elk Grove Visibility Control Area
- J. Colored Stamped Concrete Maintenance Safety Strip at Landscape Median/Turn Pocket
- K. Edging for Residential Lots
- L. Primary Streetlight
- M. Landscaping, typ. (refer to Neighborhood Entry Monument #3 - Plan Enlargement)
- N. Residential Land Use (refer to Special Planning Area Document, Chapter 2)

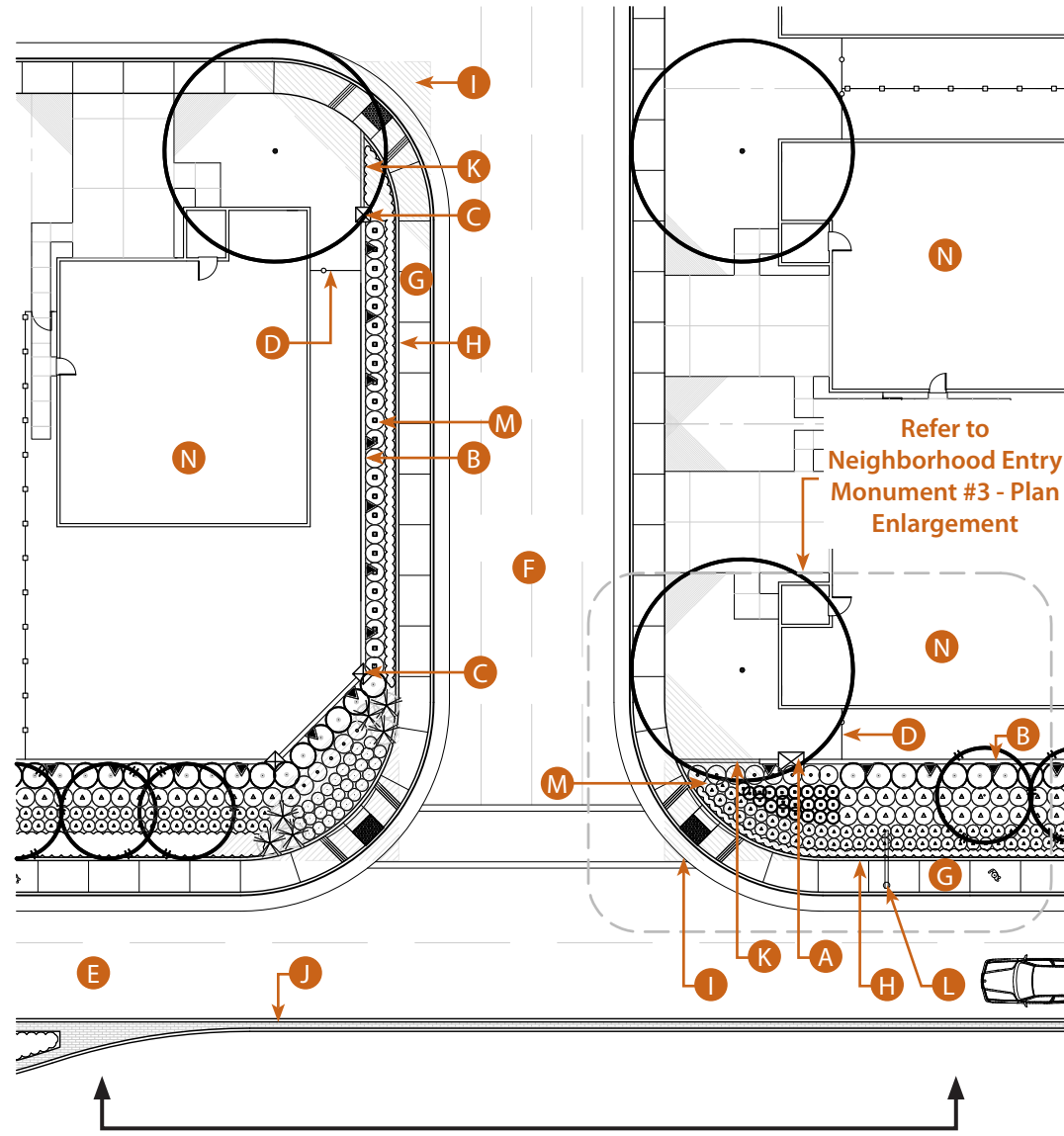

Neighborhood Entry Monument #3 - Plan
Not to Scale

Design Elements

Refer to General Standards & Reference Items section this chapter for more information

- 1. Primary Street Tree - Local Residential
- 2. Accent Tree
- 3. Large Shrub (not shown)
- 4. Medium Shrub
- 5. Small Shrub
- 6. Small Shrubs & Groundcover
- 7. Residential Unit Front Yard Landscaping
- 8. Vine

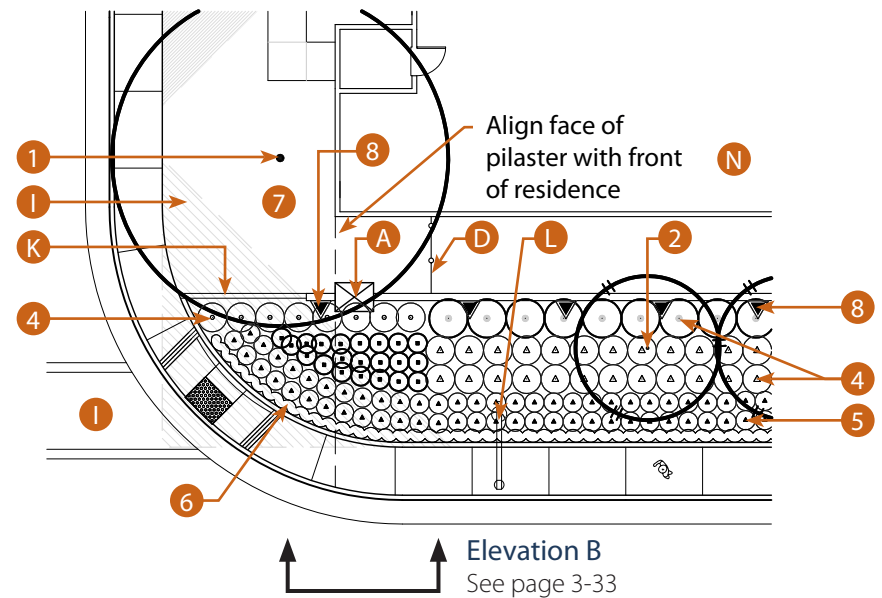

Neighborhood Entry Monument #3 - Plan Enlargement

Not to Scale

CHAPTER 3

ENTRY MONUMENTS, WALLS & FENCES: ENTRY MONUMENTS

10. Neighborhood Entry Monument #4

Neighborhood Entry Monument #4 uses a combination of a pilaster and metal panel with varied community signage. These monuments have a CMU block internal structure creating the pilaster and veneered with a manufactured stone on all sides of the monument. The pilaster is capped by a custom precast concrete cap, sized specifically to the pilaster. Neighborhood Entry Monument #4 includes a metal wrap-around lettering and logo. Refer to Neighborhood Entry Monument Overview as well as General Standards and Reference Items sections in this chapter for more information.

Design Elements

Refer to General Standards & Reference Items section this chapter for more information

- A. Neighborhood Entry Monument #4 (refer to Elevation A)
- B. Local Residential Street
- C. Concrete Sidewalk
- D. Community Wall
- E. Community Pilaster
- F. City of Elk Grove Type 3 Concrete Curb
- G. Landscaping, typ. (refer to Neighborhood Entry Monument #4 - Plan Enlargement)
- H. Residential Land Use (refer to Special Planning Area Document, Chapter 2)

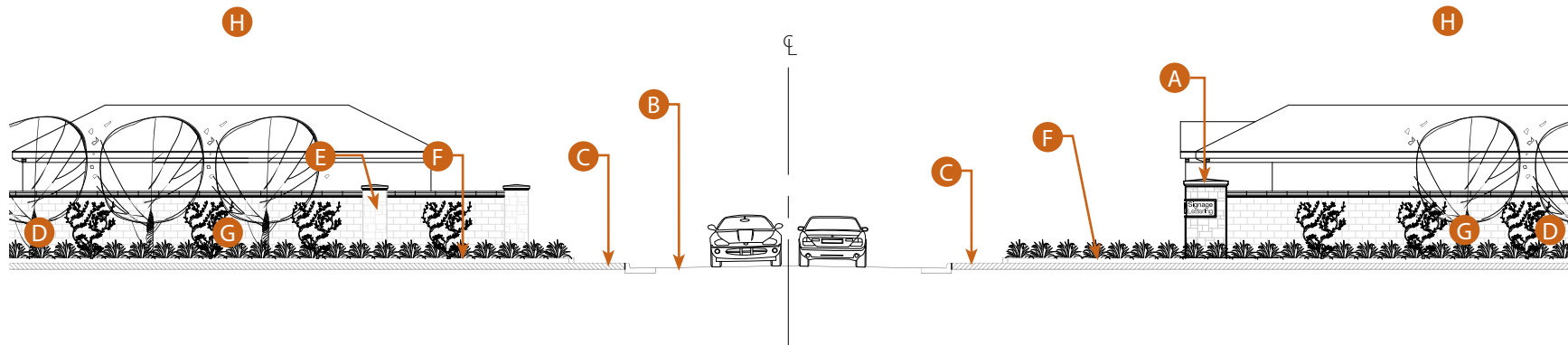

Neighborhood Entry Monument #4 - Elevation A

Not to Scale

Design Elements

Refer to General Standards & Reference Items section this chapter for more information

- | | |
|---|---|
| 1. Pilaster | 7. Stone Veneer Mortar Bed |
| 2. Pilaster Cap | 8. Lettering Letter Attached to Metal Wrap-Around Panel |
| 3. Stone Veneer | 9. Metal Wrap-Around Panel Attached to CMU Block |
| 4. Metal Wrap-Around Panel (refer to Metal Wrap-Around Panel Attachment detail) | 10. Lettering (TBD) |
| 5. Landscaping, typ. (not shown - refer to Neighborhood Entry Monument #4 - Plan Enlargement) | 11. Logo (TBD) |
| 6. Concrete Masonry Unit Block (CMU) at Monument | 12. Community Pilaster |
| | 13. Community Wall |

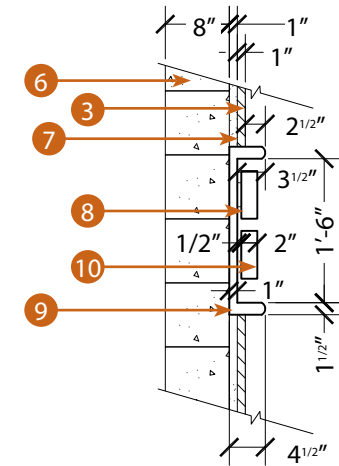

Metal Wrap-Around Panel Attachment

Not to Scale

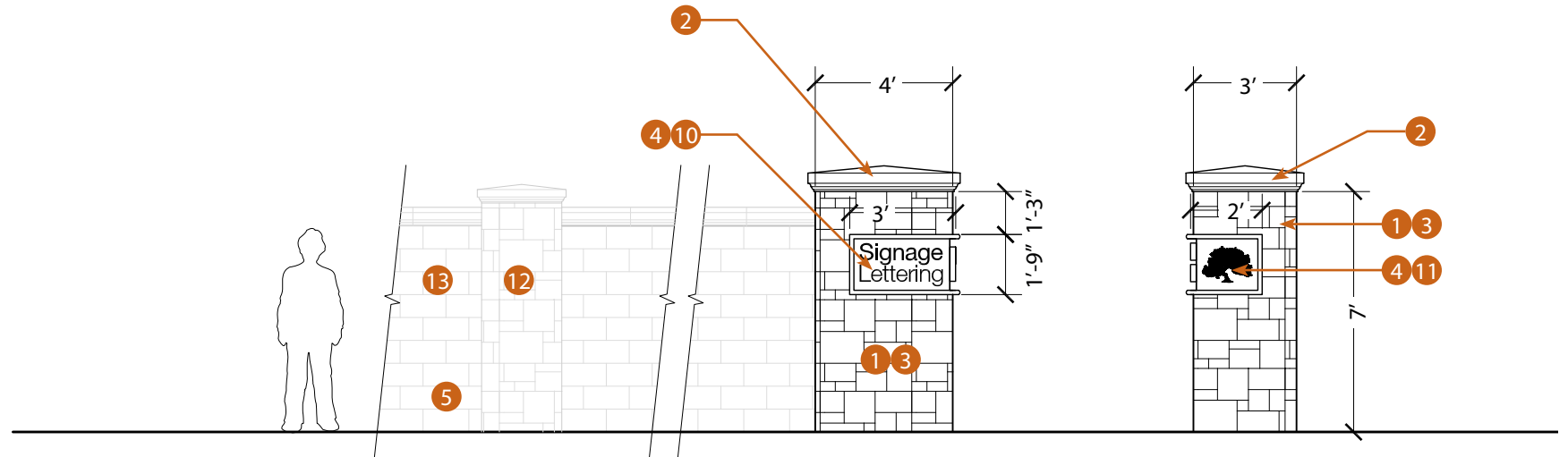

Neighborhood Entry Monument #4 - Elevation B

Not to Scale

Neighborhood Entry Monument #4 - Section

Not to Scale

CHAPTER 3

ENTRY MONUMENTS, WALLS & FENCES: ENTRY MONUMENTS

Design Elements

Refer to General Standards & Reference Items section this chapter for more information

- A. Neighborhood Entry Monument #4
- B. Community Wall
- C. Community Pilaster
- D. Residential Wood Fence
- E. Residential Collector
- F. Local Residential Street
- G. Concrete Sidewalk
- H. City of Elk Grove Type 3 Concrete Curb
- I. City of Elk Grove Visibility Control Area
- J. Colored Stamped Concrete Maintenance Safety Strip at Landscape Median/Turn Pocket
- K. Edging for Residential Lots
- L. Primary Streetlight
- M. Landscaping, typ. (refer to Neighborhood Entry Monument #4 - Plan Enlargement)
- N. Residential Land Use (refer to Special Planning Area Document, Chapter 2)

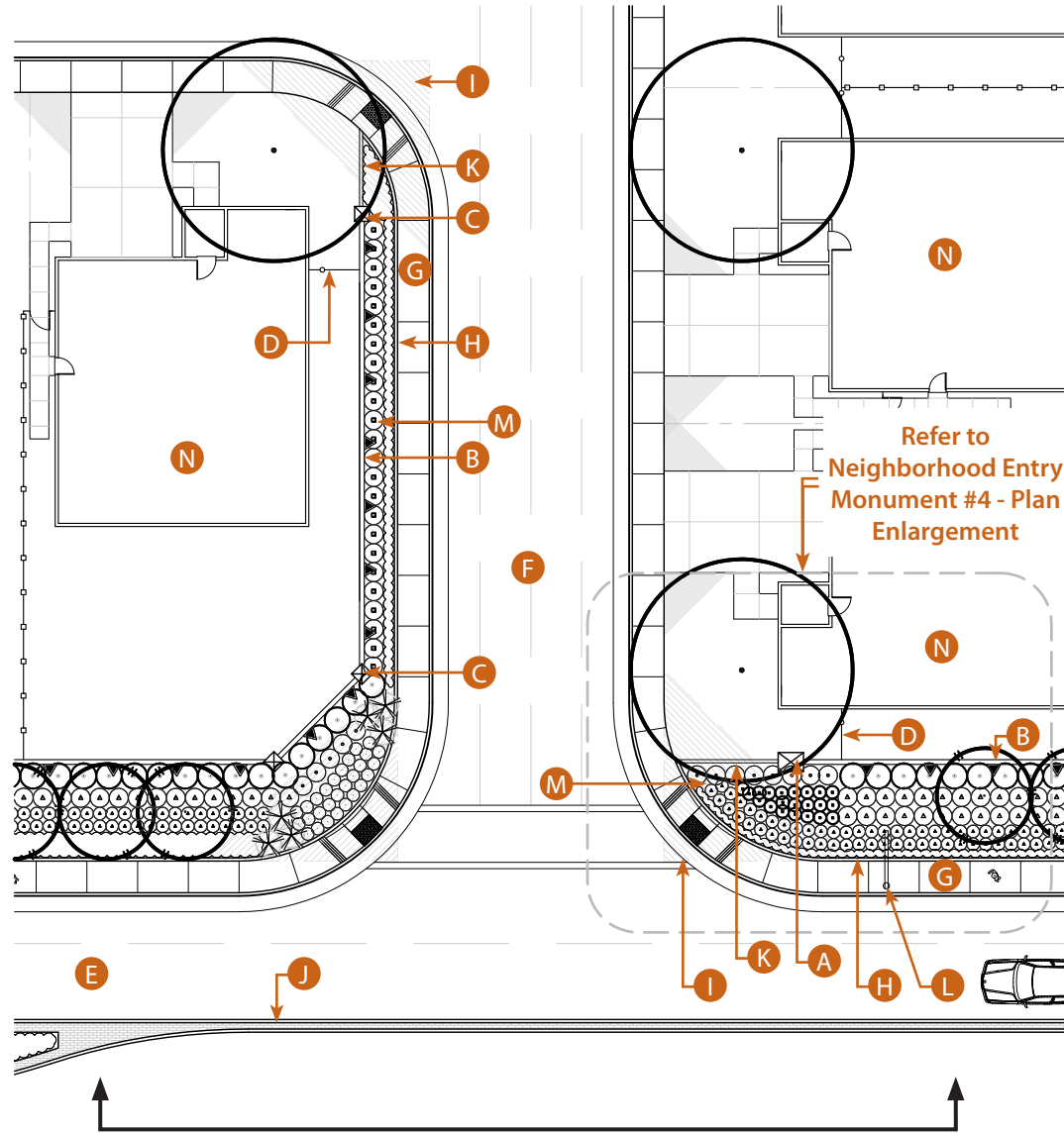

Neighborhood Entry Monument #4 - Plan
Not to Scale

Elevation A
See page 3-36

Design Elements

Refer to General Standards & Reference Items section this chapter for more information

- 1. Primary Street Tree - Local Residential
- 2. Accent Tree
- 3. Large Shrub (not shown)
- 4. Medium Shrub
- 5. Small Shrub
- 6. Small Shrubs & Groundcover
- 7. Residential Unit Front Yard Landscaping
- 8. Vine

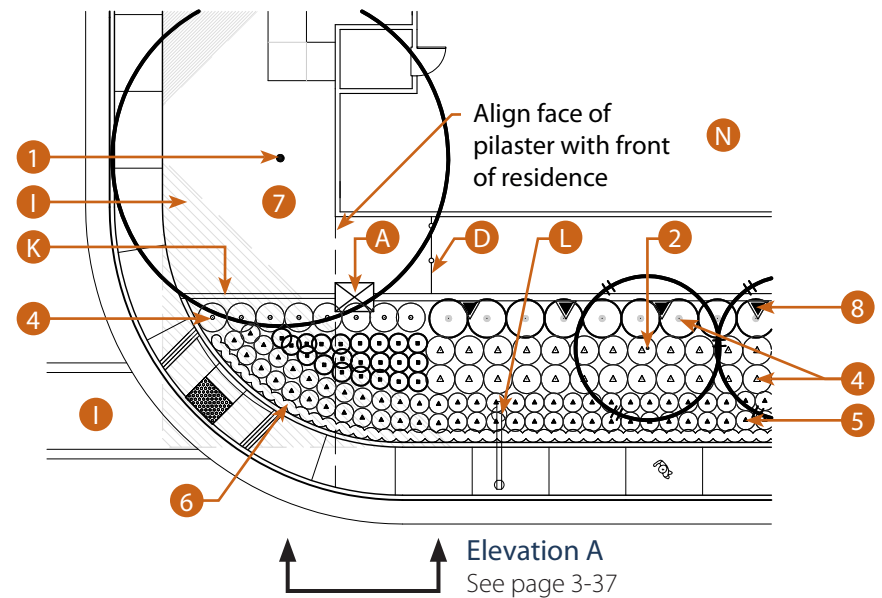

Neighborhood Entry Monument #4 - Plan Enlargement

Not to Scale

11. Gateway Features

Gateway features are free-standing monuments that signify entry into unique sections of the Plan Area. The design of each gateway feature shall be consistent with the Plan Area's surrounding architectural or natural features. Locations and design of all gateway features shall be as directed by the City.

12. Employment Area Entry Monument

Employment Area Entry Monuments are the primary signage (including lettering and logos) for office and light industrial/flex land uses within the Plan Area. Employment Area Entry Monuments shall be located near the primary driveway entrance into the office or light industrial/flex project. Additionally, Employment Area Entry Monuments may be located within the interior project site of each office and light industrial/flex land uses in order to provide the user a means of locating the specific tenant.

The height, width and scale of each Employment Area Entry Monument may vary depending on the project type and land use. The employment area monumentation lettering may be modified as necessary to fit the particular land use and final building product on the project site. The guidelines represented in this section are not intended to limit design creativity, but provide consistent implementation of monumentation and signage. Design implementation and materials may be substituted from those specified in this Manual, as long as the design consistency of all monumentation is preserved throughout the Plan Area. Any deviation to materials and design intent shall be approved by the City.

The Employment Area Entry Monument has a CMU block internal structure creating the pilaster, which is veneered with a manufactured stone on all sides of the monument. The pilaster is capped by a custom precast concrete cap, sized specifically to the pilaster element. Attached to the pilaster is a metal grid panel with metal accent panel and arched metal panel cap. Refer to General Standards and Reference Items section for additional information. Employment Area Entry Monuments are not required but are strongly encouraged to promote the Plan Area's design aesthetic and distinct identity.

The designs illustrated in this section are not meant to preclude the use of corporate signage/branding for individual tenants.

Design Elements

Refer to General Standards & Reference Items section this chapter for more information

- | | |
|--|--|
| 1. Pilaster | 10. Concrete Masonry Unit Block (CMU) at Monument |
| 2. Pilaster Cap | 11. Stone Veneer Mortar Bed |
| 3. Arched Metal Panel Cap | 12. Internally Illuminated Box attached to CMU Block |
| 4. Metal Grid Panel | 13. Vertical Lettering Panel |
| 5. Perforated Metal Panel | 14. Logo |
| 6. Metal Accent Panel | |
| 7. Metal Tenant Sign Lettering Panel, typ. | |
| 8. Stone Veneer | |
| 9. Landscaping, typ. (not shown) | |

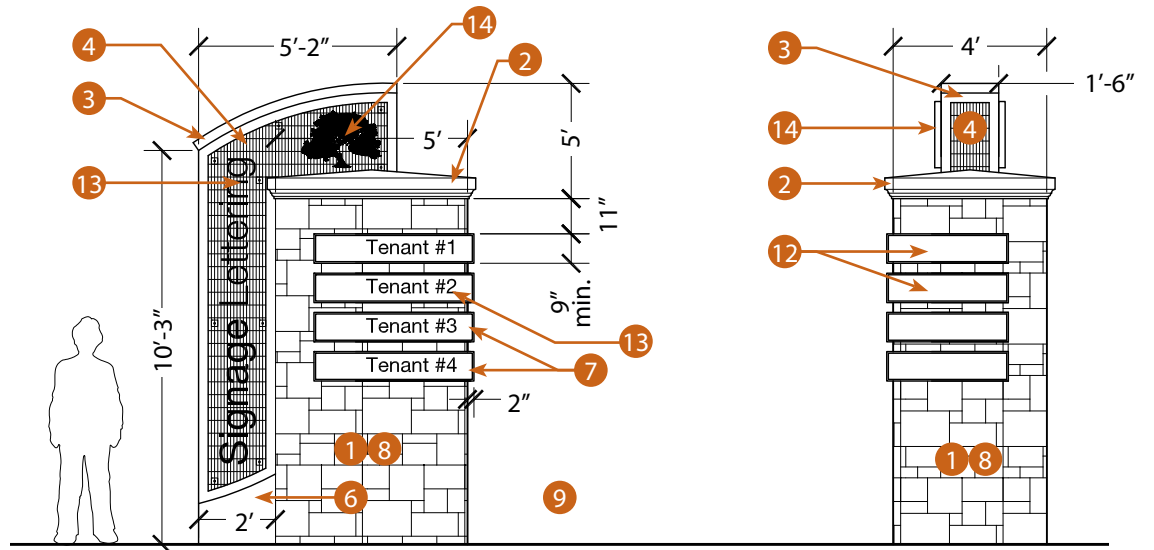

Employment Area Entry Monument Design Concept 1 - Elevation

Not to Scale



Example of Arched Metal Panel Cap



Example of Metal Accent Panel

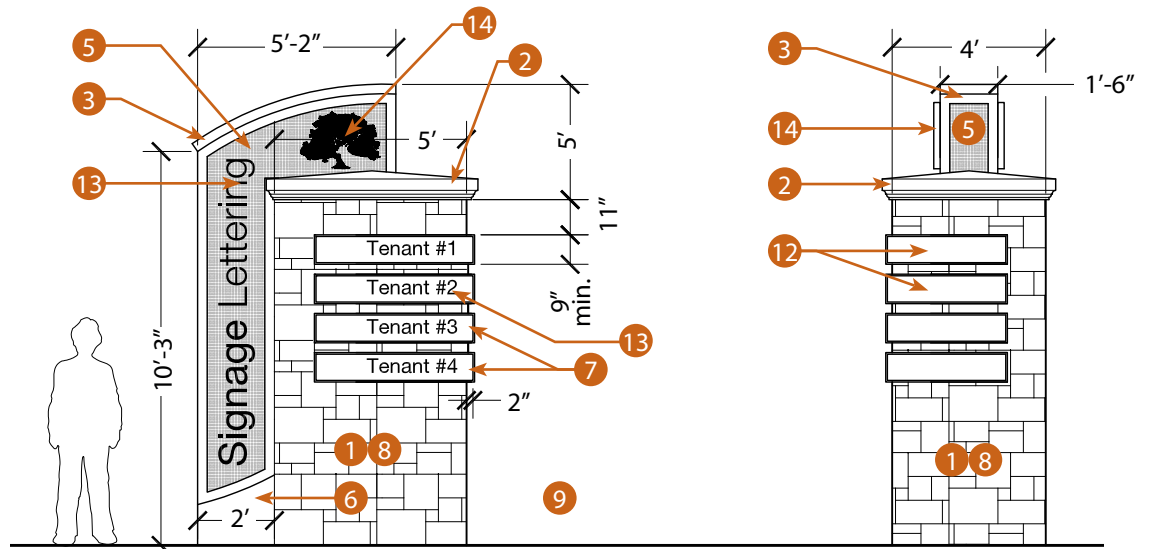

Employment Area Entry Monument Design Concept 2 - Elevation

Not to Scale

CHAPTER 3

ENTRY MONUMENTS, WALLS & FENCES: WALLS & FENCES

D. WALLS & FENCES

1. Walls & Fences Overview

Community walls, pilasters and fences are intended to provide safety, privacy, community theming, identification, and noise reduction along Arterial, Collector, and Primary streets. Walls and fences also delineate property lines and serve as visual and physical separation between land uses. All walls and fences shall utilize the same common elements and be consistent across all land uses within the Plan Area. All community walls, pilasters and fences shall not impede the view of pedestrians and vehicles at road crossings or other intersections and shall comply with all City view triangle and sight distance requirements. Refer to the Walls and Fences Application Plan, this chapter, for wall and fence locations.

A few examples of the various types of Walls & Fences found with the Plan Area



Community Pilaster & Wall



Residential Wood Fence



Split Rail Fence

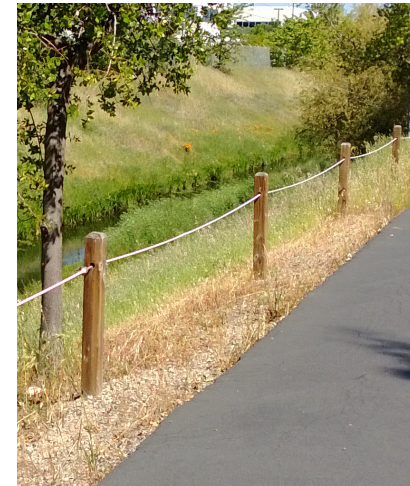

Post & Cable

2. Walls & Fences Plan

The Walls & Fences Plan illustrates the location of fencing types within the Plan Area and provides adjacent land use context. Fencing type and location may be adjusted or determined by the City.

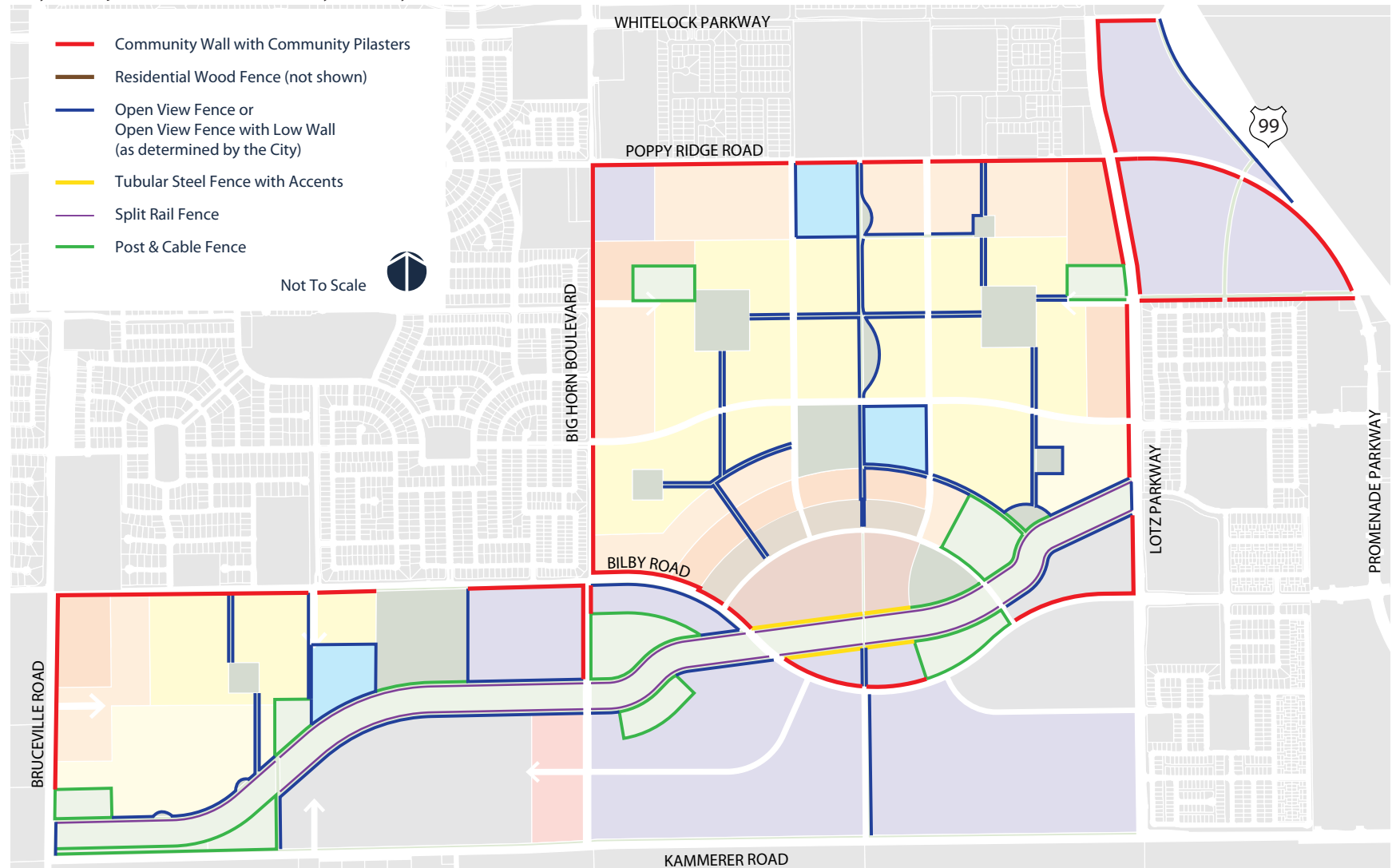

CHAPTER 3

ENTRY MONUMENTS, WALLS & FENCES: WALLS & FENCES

3. Community Pilaster

Community Pilasters shall be located at the beginning and terminus of all Community Walls, at equal spacing based on the overall length of the wall (100' o.c. max) and at a change of wall direction. Community Pilasters shall also be located at the beginning and terminus of Open View Fences or Open View Fences with Low Walls, at equal spacing (100' o.c. max) based on the overall length of the fence and at any change of direction. Community Pilasters shall also occur where an Open View Fence or Open View Fence with Low Wall intersects with each single family residential lot. Community Pilasters shall be centered on the wall or fence and may overlap the property line. All Community Pilasters shall be constructed out of CMUs, veneered with stone on all four sides, and capped with a concrete pilaster cap. Refer to General Standards and Reference Items section this chapter for more information.

Example Design Elements

- A. Community Pilaster
- B. Pilaster Cap
- C. Stone Veneer
- D. Finished Grade

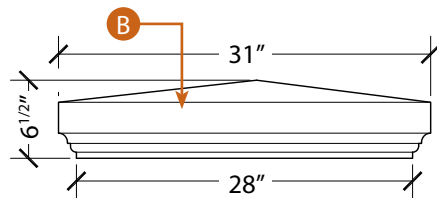

**Community Pilaster Cap
Enlargement - Not to Scale**

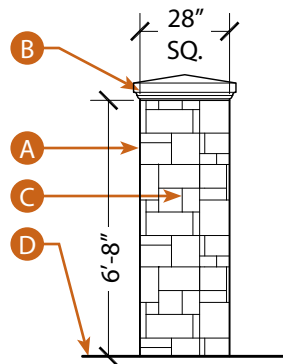

**Community Pilaster
Elevation -
Not to Scale**



**Community Pilaster
Stone Veneer Sample**
(refer to General Standards
and Reference Items)

4. Low Pilaster

Low pilasters shall be used at the entrances to greenways and where the greenway intersects perpendicularly with any street. Refer to Chapter 5 for more information and for application of pilasters in a greenway or Major Drainage Channel. Low Pilasters may also be used in other locations as determined by the City. Low Pilasters are a decorative element that creates a sense of community, and may be used in conjunction with other walls or as a stand alone decorative pilaster. Low Pilasters shall be constructed of CMUs, veneered with stone on all four sides, and capped with a concrete pilaster cap. Refer to General Standards and Reference Items section this chapter for more information.

Example Design Elements

- a. Low Pilaster
- b. Pilaster Cap
- c. Stone Veneer
- d. Split Rail Fence

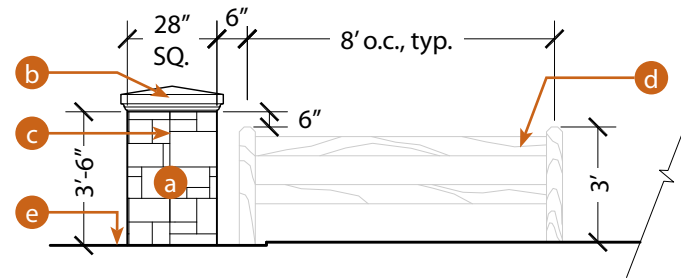

Low Pilaster Elevation - Not to Scale

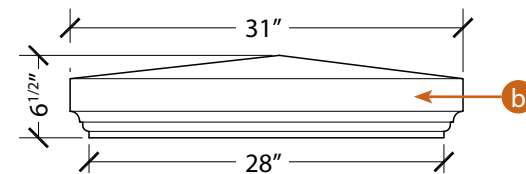

Low Pilaster Cap Enlargement - Not to Scale

5. Community Walls

Community Walls are constructed out of split face CMUs with a custom precast concrete cap and use the “Proto II” wall system by Basalite*. Community Walls shall be 6’ tall throughout all land uses. These walls may be taller with approval from the City and as required by a noise study. If elevation changes are required within the Community Wall, the wall may be stepped. Community Walls shall be located within the Landscape Area of a Landscape Corridor with the back of the wall located on the property line. Community Pilasters shall be located as specified in the Community Pilaster section in this chapter. Additionally, Community Walls shall not impede the view of pedestrians and vehicles at road crossing or other intersections, and shall comply with all City view triangle and sight distance requirements. Community Walls shall only be located between single-family residential land uses abutting medium-density residential, high-density residential, office, light industrial/flex and commercial land uses and the transit corridor. Community Walls shall not be used where single family residential abuts schools, parks, drainage channels and greenways. At all entrances to residential neighborhoods, a Community Wall shall be used. No Residential Wood Fences shall be used in this situation. Refer to Community Wall Locations at Single Family Residential Entry Plan on opposing page for more information. Refer to the Walls & Fences Application Plan in this chapter for the location of Community Walls. Refer to General Standards and Reference Items section in this chapter for more information.

*=Or approved equivalent

Example Design Elements

- A. Proto II Wall
- B. Wall Cap with void for Proto II Wall System’s Tensioning Hardware
- C. Community Pilaster
- D. Finished Grade
- E. Concrete footing per Engineer (not shown)

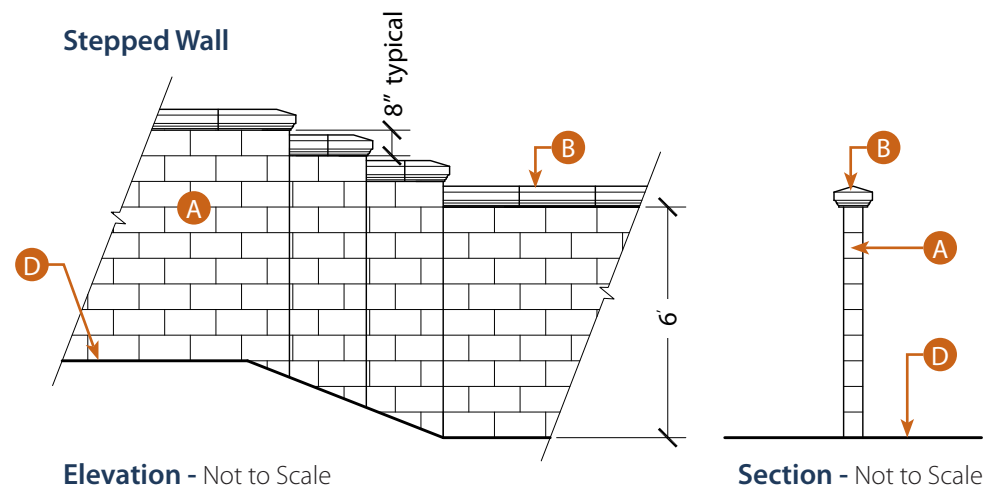
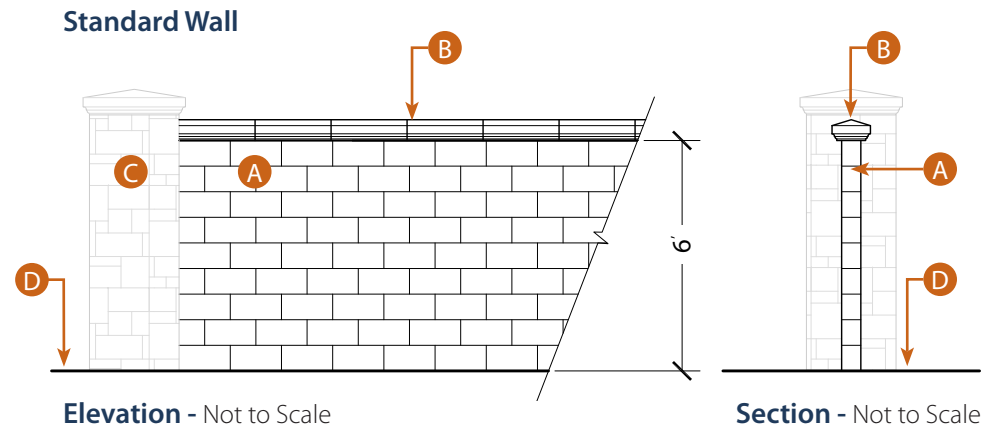

CHAPTER 3

ENTRY MONUMENTS, WALLS & FENCES: WALLS & FENCES



Example of Community Wall



Community Wall Color

(refer to General Standards and Reference Items section)

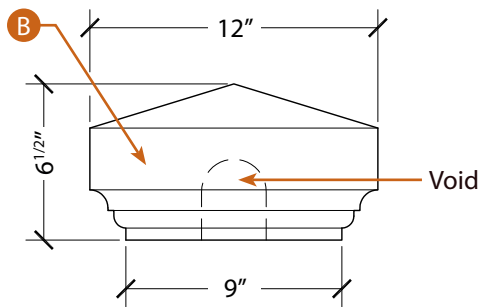

Wall Cap Enlargement - Not to Scale

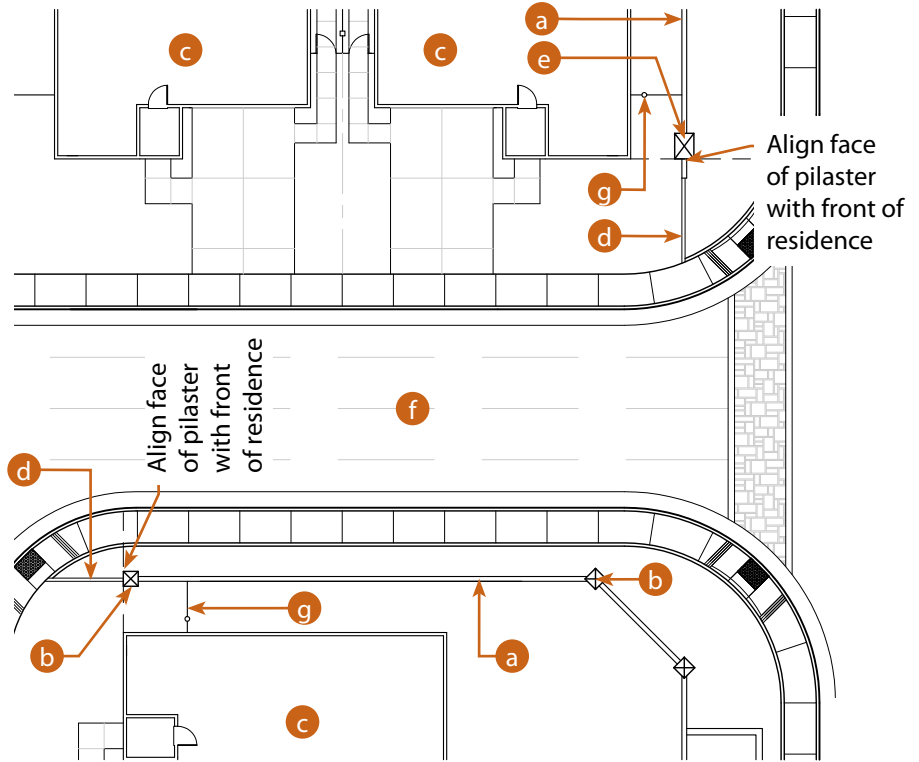

Community Wall Locations at Single-Family Residential Entry Plan

Not to Scale

- a. Community Wall (at neighborhood entry)
- b. Community Pilaster
- c. Single-Family Residence
- d. Edging at Residential Lot
- e. Neighborhood Entry Monument
- f. Local Residential Street (refer to Chapter 2)
- g. Residential Wood Fence

6. Residential Wood Fence

Residential Wood Fences shall be located primarily in front yards as well as side and rear yard property lines at single-family residential lots. Residential Wood Fences may also be used in other residential applications as determined by the City. Residential Wood Fences shall not be used at the entrance to residential neighborhoods (refer to Community Wall Locations at Single Family Residential Entry Plan in this chapter for more information) or adjacent to City and CCSD maintained areas. Refer to the Walls & Fences Application Plan in this chapter for more information regarding Residential Wood Fence Locations. Refer to General Standards and Reference Items section in this chapter for more information.

Example Design Elements

- A. Residential Wood Fence
- B. 1" x 6" cedar overlapped fence boards (sawn texture). Overlap subsequent boards by 1" as shown.
- C. 2" x 6" cedar cap
- D. 2" x 6" cedar rails
- E. 4" x 6" cedar post
- F. Finished Grade
- G. Community Pilaster

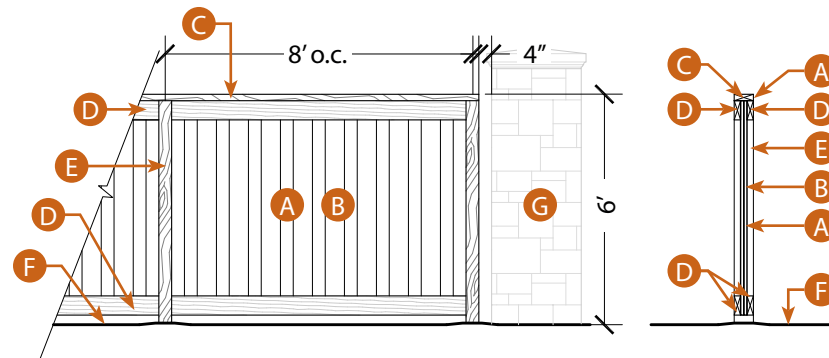

Elevation & Section - Not to Scale

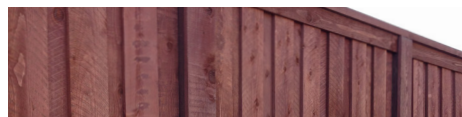

Example of Residential Wood Fence

7. Open View Fence

Open View Fences shall be located in areas where security is required, while still maintaining the view between land uses. Community Pilasters shall be located along Open View Fence as specified in the Community Pilaster section of this chapter. Additionally, Open View Fences shall be located at the property line of the following land uses:

- As allowed by the City and CCSD

Open View Fences may also be used in other locations as determined by the City. Refer to the Walls & Fences Application Plan in this chapter for the location of Open View Fences. Refer to General Standards and Reference Items section in this chapter for more information.

Example Design Elements

- a. Open View Fence
- b. Community Pilaster
- c. Finished Grade

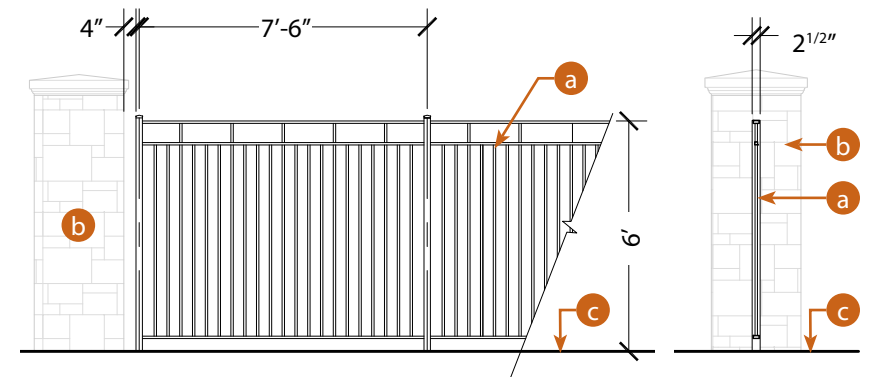

Elevation & Section - Not to Scale

CHAPTER 3

ENTRY MONUMENTS, WALLS & FENCES: WALLS & FENCES

8. Open View Fence with Low Wall

Open View Fences with Low Walls shall be located in areas where security is required, while still maintaining the view between land uses. Community Pilasters shall be located along Open View Fence with Low Wall as specified in the Community Pilaster section of this chapter. Additionally, Open View Fences with Walls shall be located at the property line of the following land uses:

- CCSD maintained areas adjacent to residential (low, medium, and high density) and office land uses

Open View Fences with Low Walls may also be used in other locations as determined by the City. Refer to the Walls & Fences Application Plan in this chapter for the location of Open View Fences with Low Walls. Refer to General Standards and Reference Items section in this chapter for more information.

Example Design Elements

- A. Open View Fence with Low Wall C. Finished Grade
B. Community Pilaster

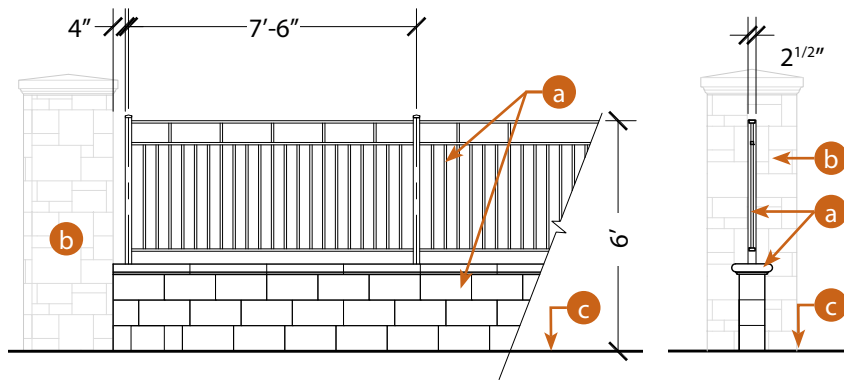

Elevation & Section - Not to Scale

9. Split Rail Fence

Split rail fences shall be located adjacent to the Major Drainage Channel Trail Landscaping, entrances to Greenways and Major Drainage Channels, as well as other locations as determined by the City. Refer to Materials Overview section in this chapter for more information.



Example of Concrete Split Rail Fencing

10. Post and Cable Fence

Post and Cable Fences shall be located around all sides of all drainage facilities located within the Plan Area. This shall include Drainage Basins, Joint Use Park/Detention Facilities, as well as locations where these drainage facilities abut the Major Drainage Channel. Refer to the Walls & Fences Application Plan for the location of Post and Cable Fence. The Post and Cable Fence may also be used in other locations as determined by the City of Elk Grove. Refer to Materials Overview section in this chapter for more information.

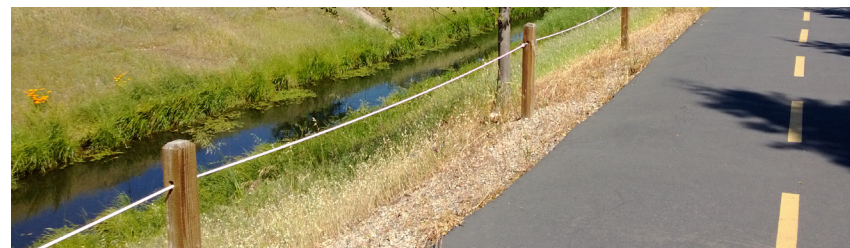

Example of Post and Cable Fencing

11. Other Walls & Fences

a. Tubular Steel Fence with Accents

Tubular Steel Fence with Accents shall be located in the mixed use village center land use and, as applicable, within mixed use residential land use. The Tubular Steel Fence with Accents shall be used in the village center area where paving in the form of gathering spaces and plazas about the Major Drainage Channel. Additionally, the Tubular Steel Fence with Accents may be used in Greenways, Drainage Corridors and Drainage Facilities, as determined by the City and CCSD. Lastly, Tubular Steel Fence with Accents may be used to enclose outdoor eating areas connected to restaurants, coffee bars or other eateries.

Artistic fence embellishments, similar to laser-cut filigrees, resembling wildlife and plants that inhabit the Plan Area (Hérons, Swansons Hawk, Garter Snake, Juncus, Oaks, etc.) are recommended in Greenways, Drainage Corridors and Drainage Facilities. Design of artistic features shall be approved by the City and CCSD. Refer to the Walls & Fences Application Plan for the location of Tubular Steel Fence with Accents. Tubular Steel Fence with Accents may be used in other locations a determined by the City. Refer to General Standards and Reference Items section in this chapter for more information.

Example Design Elements

- A. Tubular Steel Fence with Accents
- B. Finished Grade
- C. Artistic Fence Embellishments (not shown)

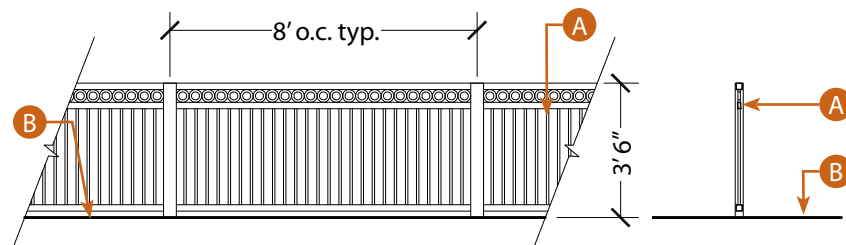

Elevation & Section - Not to Scale

b. Courtyard Wall

Courtyard Walls may be located in residential land uses where a private outdoor living area (as defined in the SPA) is allowed. Courtyard walls may also be located in plaza areas within office and light industrial/flex land uses and other landed uses as allowed by the City. These walls shall be constructed out of CMUs, veneered with stucco on all sides (as determined by the City), and capped with a precast concrete wall cap. Refer to General Standards and Reference Items section in this chapter for more information.

Example Design Elements

- a. Courtyard Wall
- b. Standard CMU with Stucco Finish
- c. Wall Cap
- d. Finished Grade

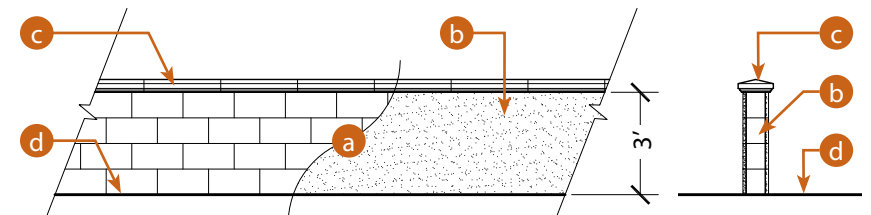

Wall Elevation & Section - Not to Scale

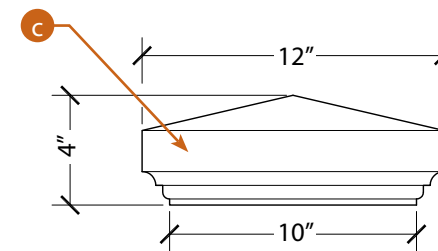

Wall Cap Enlargement - Not to Scale

CHAPTER 3

ENTRY MONUMENTS, WALLS & FENCES: WALLS & FENCES

c. Stone Veneer Courtyard Wall

Stone Veneer Courtyard Walls may be located in residential land uses where a private outdoor living area (as defined in the SPA) is allowed. Stone Veneer Courtyard Walls may also be located in plaza areas within office and light industrial/flex land uses and other land uses, as allowed by the City. Stone Veneer Courtyard Walls shall be constructed out of CMUs, veneered with stone on all sides (as determined by the City), and capped with a precast concrete wall cap. Refer to General Standards and Reference Items section in this chapter for more information.

Example Design Elements

- A. Courtyard Wall
- B. Stone Veneer
- C. Wall Cap
- D. Finished Grade

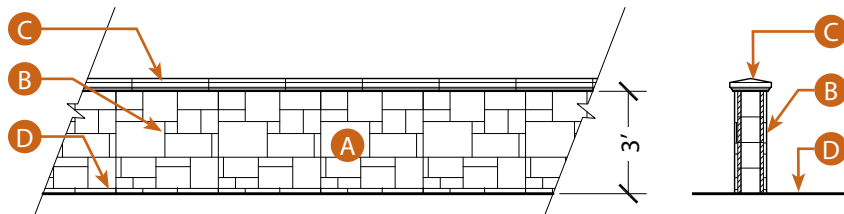

Stone Veneer Courtyard Wall Elevation & Section - Not to Scale

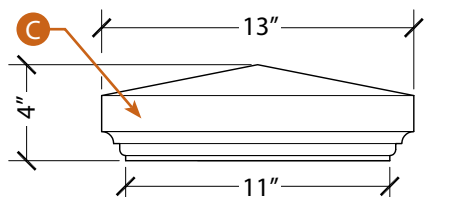

Stone Veneer Courtyard Wall
Cap Enlargement - Not to Scale

d. Seatwall

Seatwalls may be located in medium and high density residential, mixed use residential, mixed use village center land uses, as well as in office, light industrial/flex and commercial land uses. Seatwalls may also be used in other locations as determined by the City. Seatwalls are a decorative element allowing pedestrians to sit and gather within specific areas of the Plan Area. Seatwalls may be used in conjunction with Low Pilasters. Seatwalls shall be constructed out of CMUs, veneered with stucco on all sides (as determined by the City), and capped with a precast concrete wall cap. Seatwall caps shall be flat without any peak to allow pedestrians to sit on the cap. Refer to General Standards and Reference Items section in this chapter for more information.

Example Design Elements

- a. Seatwall
- b. Standard Smooth Face CMU with Stucco Finish
- c. Wall Cap
- d. Finished Grade

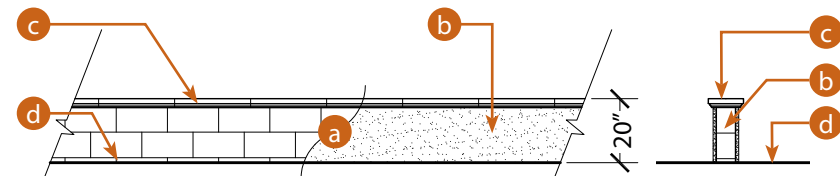

Seatwall Elevation & Section - Not to Scale

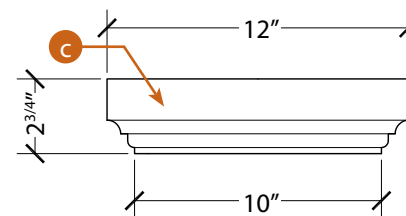

Seatwall Cap
Enlargement -
Not to Scale

e. Stone Veneer Seatwall

Stone Veneer Seatwalls may be located in medium and high density residential, mixed use residential, mixed use village center land uses, as well as in office, light industrial/flex and commercial land uses. Stone Veneer Seatwalls may also be used in other locations as determined by the City. Stone Veneer Seatwalls are a decorative element allowing pedestrians to sit and gather within specific areas of the Plan Area. Stone Veneer Seatwalls may be used in conjunction with Low Pilasters. Stone Veneer Seatwalls shall be constructed out of CMUs, veneered with stone on all sides (as determined by the City), and capped with a precast concrete wall cap. Seatwall caps shall be flat without any peak to allow pedestrians to sit on the cap. Refer to General Standards and Reference Items section in this chapter for more information.

Example Design Elements

- A. Seatwall
- B. Stone Veneer
- C. Wall Cap
- D. Finished Grade

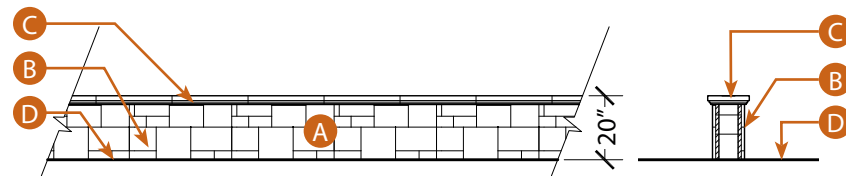

Stone Veneer Seatwall Elevation & Section - Not to Scale

