

**SIDEWALK WITH PLANTER AREA**

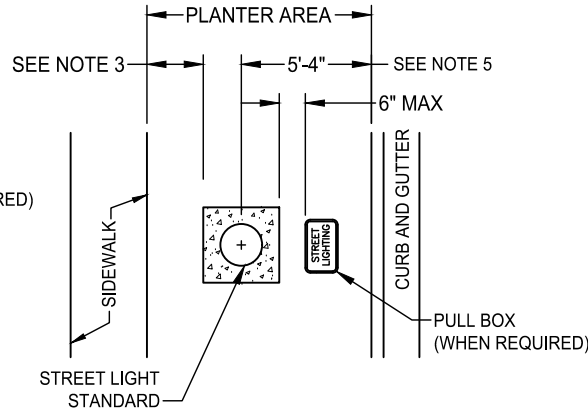

**SECTION A-A**

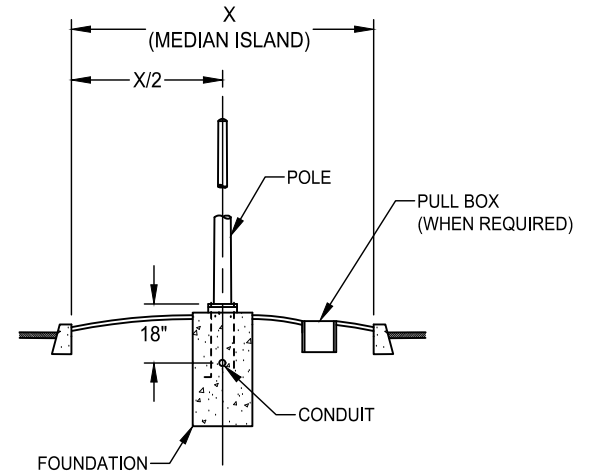

**MEDIAN**

**NOTES**

1. BACKFILL FOR CONDUIT TRENCH LOCATED UNDER CURB, GUTTER & SIDEWALK AND IN UNIMPROVED AREAS SHALL BE COMPACTED TO 90% RELATIVE COMPACTION. BACKFILL FOR CONDUIT TRENCH LOCATED IN PAVEMENT SHALL BE COMPACTED TO 95% RELATIVE COMPACTION.
2. LANDSCAPING IN THE AREA OF THE STREET LIGHT STANDARD TO MATCH BASE ELEVATION AND HAVE A MINIMUM OF 12" OF CLEARANCE FROM THE BASE.
3. IF THIS LENGTH IS 12" OR LESS, PLACE 3-1/2" THICK CONCRETE FROM STREET LIGHT BASE TO EDGE OF SIDEWALK. WIDTH TO MATCH CONCRETE AROUND STREET LIGHT FOUNDATION.
4. IF CONDUIT IS LOCATED BENEATH THE SIDEWALK, IT MAY BE PLACED AT 18" DEPTH INSTEAD OF 2'.
5. IF THE PLANTER AREA IS LESS THAN 6' WIDE, THEN PLACE STREET LIGHT SO THAT THE BASE PLATE ALIGNS WITH THE EDGE OF SIDEWALK. TOP OF FOUNDATION TO MATCH SIDEWALK GRADE.
6. PULL BOXES SHALL NOT BE PLACED IN SIDEWALK. THEY SHALL BE PLACED IN PUE OR PLANTER AREA.

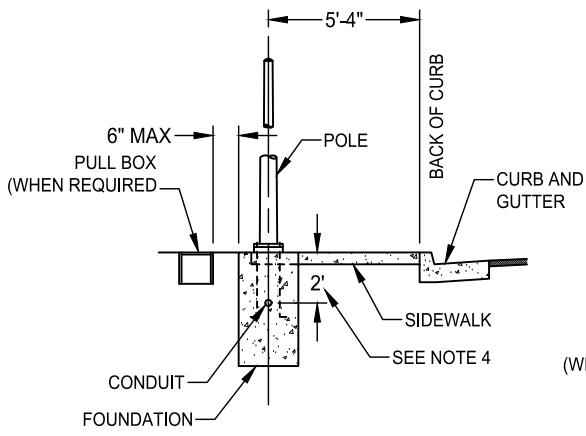

**5' TO 6' SIDEWALK**

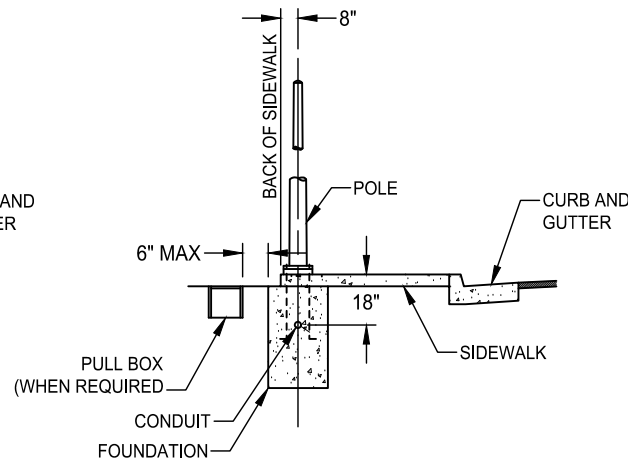

**OVER 6' SIDEWALK**

|                     |    |              |      |
|---------------------|----|--------------|------|
| DATE:<br>09/22/2007 |    | NOT TO SCALE |      |
| REVISION            | BY | APPROVED     | DATE |
|                     |    |              |      |
|                     |    |              |      |
|                     |    |              |      |

CITY OF ELK GROVE - PUBLIC WORKS

**BASE LOCATION FOR STREET LIGHT**

APPROVED BY:

*Robert M. Muddock*

CITY ENGINEER

10/24/2018

DATE



DRAWING NUMBER

**SL - 6**