

FENCE SECTION DETAIL

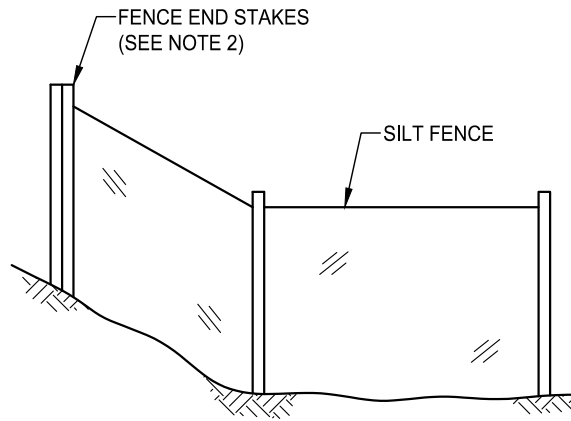

FENCE END DETAIL

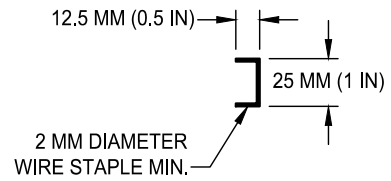

STAPLE DETAIL

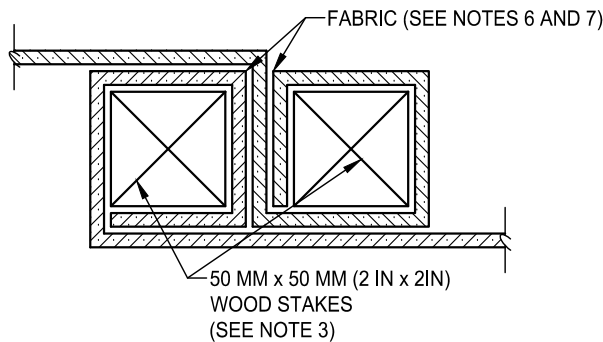

JOINT DETAIL

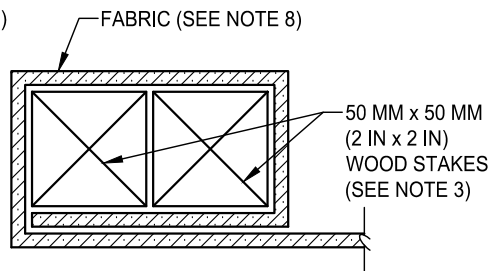

END STAKE DETAIL

NOTES:

1. CONSTRUCT THE LENGTH OF EACH REACH SO THAT THE CHANGE IN BASE ELEVATION ALONG THE REACH DOES NOT EXCEED 1/3 THE HEIGHT OF THE LINEAR BARRIER. IN NO CASE SHALL THE REACH LENGTH EXCEED 150 MM (6 IN)
2. THE LAST 2.4 M (8 FT) OF FENCE SHALL BE TURNED UP SLOPE.
3. STAKE DIMENSIONS ARE NOMINAL.
4. DIMENSIONS MAY VARY TO FIT FIELD CONDITION.
5. STAKES SHALL BE SPACED AT 2.4 M (8 FT) MAXIMUM AND SHALL BE POSITIONED ON THE DOWNSTREAM SIDE OF THE FENCE.
6. OVERLAP STAKES, AND FOLD FENCE FABRIC TO ROUND EACH STAKE ONE FULL TURN.
7. STAKES SHALL BE DRIVEN TIGHTLY TOGETHER TO PREVENT POTENTIAL FLOW THROUGH OF SEDIMENT AT THE JOINT.
8. FOR END STAKE CONDITION FOLD FENCE FABRIC AROUND (2) STAKES (1) FULL TURN AND SECURE WITH (4) STAPLES.
9. MINIMUM (4) STAPLES PER STAKE.
10. CROSS BARRIERS SHALL BE MINIMUM OF 1/3 AND MAXIMUM OF 1/2 THE HEIGHT OF THE LINEAR BARRIER.

DATE: 09/22/2007		NOT TO SCALE	
REVISION	BY	APPROVED	DATE

CITY OF ELK GROVE - PUBLIC WORKS

APPROVED BY:

 10/24/2018
 CITY ENGINEER DATE

SILT FENCE



DRAWING NUMBER

SQ - 5